



Chicago

**DIE
CASTING
MFG. CO.**

**American Zinc Base
Die Castings and
Power Transmission Equipment**

**CATALOG
2013 G**

More than 95 years of Quality and Service



DIE CASTING MFG. CO.

9148 King St., Franklin Park, IL 60131 847-671-5010
FAX 847-671-1355

Zinc Pulleys and Parts for Fractional Horse Power Applications.

Versatile Packaging UPC Bar Coding

We've designed our packaging for strong product identification. Clear, easy to read sleeve type cartons help your DIY customer to choose, on his own, the right size pulley without taking it out of the package. Bore, diameter and belt sizes are printed on each package to eliminate confusion and guessing. Our packaging makes inventory and restocking simple – saving you time and money.



PULLEY DISPLAYS

Your Do-It-Yourself
Power Transmission Department

PULLEY DISPLAY NO. 60

- 59 Packaged A-Section Pulleys
- Planogram
- Peg Board Display
- Actual Size 23" W, 20" H, 7" D
- Full View Inventory Control
- 1/2, 5/8, 3/4, Bores
- Total Weight - 37 lbs.
- Each Bore On Separate Peg
- Designed For Bin Tags

Bores	Sizes					
	1 1/2	2	2 1/2	3	4	5
1/2	4	4	4	4	4	4
5/8	4	4	4	4	4	4
3/4	3	3	3	3	3	3
Total pcs	4	11	11	11	11	11



STEEL PULLEY DISPLAY NO. SA10

- For gasoline engines and electric motors up to 18hp
- 20 steel pulleys combinations A/B groove
- Planogram
- Peg board display
- Actual size 23" w 13"h 6"d
- Full view inventory control
- 5/8", 3/4" bore sizes
- Total weight - 20 lbs.
- Top ten pulley sizes
- Each bore size on separate peg
- Designed for bin tags

Bores	Sizes				
5/8"	2 1/2"	3"	3 1/2"	4"	5"
3/4"	2	2	2	2	2
Total pcs	4	4	4	4	4

INFORMATION
A,B,O, SECTION

1. Bores $\frac{5}{8}$ ", $\frac{3}{4}$ ", $\frac{7}{8}$ ", indicated by (*k) have standard $\frac{3}{16}$ " x $\frac{3}{32}$ " keyways.
2. Bores over $\frac{7}{8}$ ", indicated by (*k) have $\frac{1}{4}$ " x $\frac{1}{8}$ " keyway.
3. Special bores, keyways, set screws can be had at a slight increase in price with production quantities.

A SECTION

For 4L or 1/2" x 11/32" belts.



B SECTION

For 5L or 21/32" x 7/16" belts.

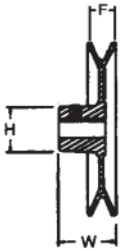

Hub size dimension of largest bore size. Dimensions are approximate.

O SECTION

For 3L or 3/8" x 1/4" belts.



HUBLESS A SECTION

For 4L or 1/2" x 11/32" belts.



SINGLE "V" GROOVED PULLEYS

Stock No.	Outside Diam.	Pitch Diam.	Diameter of Bore							No. of Spokes	Net Wt. Ozs.
			1/4"	5/16"	3/8"	1/2"	5/8"	3/4"	1"		
150-A	1 1/2"	1.25"	0	2.3	
175-A	1 3/4"	1.5"	*k	0	4.0	
200-A	2"	1.75"	*k	0	4.0	
225-A	2 1/4"	2"	*k	0	5.7	
250-A	2 1/2"	2.25"	*k	0	8.0	
275-A	2 3/4"	2.5"	*k	0	7.0	
300-A	3"	2.75"	*k	0	9.2	
325-A	3 1/4"	3"	*k	0	9.6	
350-A	3 1/2"	3.25"	*k	0	11.0	
400-A	4"	3.75"	*k	0	13.2	
450-A	4 1/2"	4.25"	*k	0	15.5	
500-A	5"	4.75"	*k	0	17.0	
550-A	5 1/2"	5.25"	*k	4	14.5	
600-A	6"	5.75"	*k	3	16.0	
700-A	7"	6.75"	*k	6	20.0	
800-A	8"	7.75"	*k	6	21.0	
900-A	9"	8.75"	*k	6	25.0	
1000-A	10"	9.75"	*k	6	28.3	
1100-A	11"	10.75"	*k	6	31.0	
1200-A	12"	11.75"	*k	6	33.0	
1400-A	14"	13.75"	*k	6	42.0	

W	F	H
1 1/8"	1 1/16"	1 5/16"
1 1 1/4"	1 1/8"	1 3/8"
1 1 1/2"	1 1/4"	1 1/2"
1 3/4"	1 1/2"	1 3/4"
2"	1 3/4"	2"
2 1/4"	2"	2 1/4"
2 1/2"	2 1/4"	2 1/2"
2 3/4"	2 1/2"	2 3/4"
3"	2 3/4"	3"
3 1/4"	3"	3 1/4"
3 1/2"	3 1/4"	3 1/2"
3 3/4"	3 1/2"	3 3/4"
4"	3 3/4"	4"
4 1/2"	4"	4 1/2"
5"	4 1/2"	5"
5 1/2"	4 3/4"	5 1/2"
6"	5"	6"
7"	6"	7"
8"	7"	8"
9"	8"	9"
10"	9"	10"
11"	10"	11"
12"	11"	12"
14"	13"	14"

All above "A" section pulleys have hollow head set screws and are supplied as follows:
1) Packaged in individual cartons. 2) Shipped in bulk lots.

Stock No.	Outside Diam.	Pitch Diam.	Diameter of Bore							No. of Spokes	Net Wt. Ozs.
			1/4"	5/16"	3/8"	1/2"	5/8"	3/4"	1"		
200-B	2"	1.5"	*k	0	5.0	
250-B	2 1/2"	2"	*k	0	7.0	
300-B	3"	2.5"	*k	0	10.0	

W	F	H
1 3/8"	1 3/16"	1 3/32"
1 1/4"	1 1/8"	1 1/4"
1 1/2"	1 1/4"	1 1/2"

All the above "B" section pulleys have hollow head set screws and are supplied as follows:
1) Packaged in individual cartons. 2) Shipped in bulk lots.

Stock No.	Outside Diam.	Pitch Diam.	Diameter of Bore							No. of Spokes	Net Wt. Ozs.
			1/4"	5/16"	3/8"	1/2"	5/8"	3/4"	1"		
100-O	1"	.9"	0	1.0	
150-O	1 1/2"	1.4"	0	2.5	
200-O	2"	1.9"	0	4.0	
250-O	2 1/2"	2.4"	0	5.25	
300-O	3"	2.9"	0	6.5	
350-O	3 1/2"	3.4"	0	8.5	
400-O	4"	3.9"	0	10.0	

W	F	H
7/8"	1/2"	3/4"
1"	1/2"	1 1/16"
1 1/4"	1"	1 1/8"
1 1/2"	1 1/4"	1 1/2"
2"	1 1/2"	2 1/8"
2 1/2"	2"	2 1/4"
3"	2 1/2"	3 1/8"
3 1/2"	3"	3 1/4"
4"	3 1/2"	4 1/8"

All "O" section single grooved pulleys have hollow head set screws and are supplied in standard die cast finish and shipped in bulk lots.

Stock No.	Outside Dia.	Pitch Diam.	Diameter of Bore							No. of Spokes	Net Wt. Ozs.
			1/4"	5/16"	3/8"	1/2"	5/8"	3/4"	1"		
H-200-A	2"	1.75"	0	3.0	
H-250-A	2 1/2"	2.25"	*k	0	5.0	
H-300-A	3"	2.75"	*k	0	6.0	

W	F	H
4 3/64"	5/8"	5/8"
5/8"	5/8"	5/8"

All hubless pulleys have hollow head set screws and are supplied in Standard die cast finish and shipped in bulk lots. Use side by side for multiple drives.
Bore Size Identification No. 1/4"-1, 5/16" - 2, 3/8" - 3, 1/2" - 5, 5/8" - 6, 3/4" - 7, 1" - 8

A SECTION

For 4L or 1/2" x 11/32" belts.



"V" GROOVE STEP PULLEYS



Stock No.	No. of Steps	1st Step	2nd Step	3rd Step	4th Step	1/2" 5/8" 3/4" 1"				Net Wt. Ozs.	W	L	H				
						1st Step	2nd Step	3rd Step	4th Step								
113	Two	2"	2 1/2"			•	*k	1.75"	2.25"				7.0	1 1/4"	3/4"	1"	
150	"	2"	3"			•	*k	1.75"	2.75"				9.0	1 1/4"	3/4"	7/8"	
145	Three	1 3/4"	2 1/4"	2 3/4"		•	*k	*k	1.50"	2.00"	2.50"		9.75	1 3/4"	1 1/8"	1 5/16"	
146	"	2"	3"	4"		•	*k	*k	1.75"	2.75"	3.75"		19.0	1 7/8"	1 3/4"	1 1/16"	
149	"	3"	3 1/2"	4"		•	*k	*k	2.75"	3.25"	3.75"		20.0	1 3/4"	1 1/8"	1"	
148	"	3 1/2"	4"	4 1/2"		•	*k	*k	3.25"	3.75"	4.25"		27.0	1 3/4"	1 3/16"	1"	
140	Four	1 3/4"	2 1/4"	2 3/4"	3 1/4"	•	*k	*k	1.50"	2"	2.5"	3.00"	16.0	2 5/16"	1 3/4"	1"	
141	"	2"	2 1/2"	3 1/2"	4"	•	*k	*k	1.75"	2.25"	3.25"	3.75"	22.0	2 1/2"	1 5/8"	1 1/8"	
143	"	3"	3 1/2"	4"	4 1/2"	•	*k	*k	2.75"	3.25"	3.75"	4.25"	31.0	2 5/16"	1 3/4"	1"	
147	"	2"	3"	4"	5"	•	*k	*k	*k	1.75"	2.75"	3.75"	4.75"	36.0	2 1/2"	1 3/4"	1 3/16"

All pulleys are furnished with hollow head set screws.

STEEL PULLEYS for "A" or "B" belts

Used on gasoline engine and electric motor applications rated from 1 to 18 H.P.

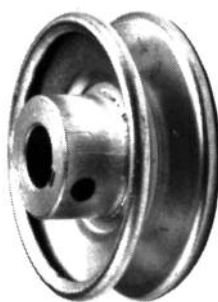

Stock No.	Outside Diam.	Diameter of Bore		Net Wt. Ozs.
		5/8"	3/4"	
S200 AB	2"	*k		8.0
S250 AB	2 1/2"	*k	*k	7.0
S300 AB	3"	*k	*k	8.0
S350 AB	3 1/2"	*k	*k	9.0
S400 AB	4"	*k	*k	11.0
S500 AB	5"	*k	*k	14.5



Bore Size	W	C	L	H
5/8"	1 15/32"	1 1/32"	1"	1 1/4"
3/4"	1 15/32"	1 1/32"	1"	1 1/2"

"H" dimension for A & B section

A SECTION



VARIABLE SPEED PULLEYS

Stock No.	Outside Diam.	Max Pitch Diam.	Min. Pitch Diam.	1/2"	Bore Diameter		Net Wt. Ozs.
					5/8"	3/4"	
325 VP	3 1/4"	2.9"	1.8"	•	*k	*k	12
350 VP	3 1/2"	3.1"	2.0"	•	*k		15 1/2
375 VP	3 3/4"	3.3"	2.4"	•	*k		16
400 VP	4"	3.6"	2.6"	•	*k		17 1/2

DIE CAST SHAFT COLLARS



Stock No.	Bore Diameter	Outside Diameter	Width	Set Screw Size	Net Weight
3003*	3/16"	9/16"	3/8"	10-24 Thread	62 to 1lb.
3004*	1/4"	5/8"	1 1/32"	10-24 Thread	53 to 1lb.
3005*	5/16"	1 1/16"	1 1/32"	10-24 Thread	44 to 1lb.
3006*	3/8"	3/4"	1 1/32"	10-24 Thread	41 to 1lb.
3008	1/2"	1"	1/2"	5/16-18 Thread	1 oz.
3010	5/8"	1 1/8"	1/2"	5/16-18 Thread	1 1/2 oz.
3011	1 1/16"	1 1/8"	9/16"	5/16-18 Thread	2 oz.
3012	3/4"	1 1/4"	1/2"	5/16-18 Thread	2 oz.
3014	7/8"	1 3/8"	5/8"	5/16-18 Thread	2 oz.
3015	1 5/16"	1 9/16"	3/4"	5/16-18 Thread	3 1/2 oz.
3100	1"	1 5/8"	3/4"	5/16-18 Thread	3 1/2 oz.
3101	1 1/16"	1 13/16"	3/4"	5/16-18 Thread	4 oz.
3102	1 1/8"	1 13/16"	3/4"	5/16-18 Thread	4 oz.
3103	1 3/16"	1 13/16"	3/4"	5/16-18 Thread	3 1/2 oz.
3104	1 1/4"	1 13/16"	3/4"	5/16-18 Thread	3 oz.
3106	1 3/8"	2"	3/4"	5/16-18 Thread	4 oz.
3107	1 7/16"	2 1/16"	1 1/16"	5/16-18 Thread	5 1/2 oz.
3115	1 15/16"	2 1/16"	1 3/16"	3/8-16 Thread	10 oz.

*Furnished with hollow head set screw. All shaft collars are furnished with slotted headless set screws. Special screws may be had at a slight increase in price with production quantities.

PILLOW BLOCKS



FLANGED SINTERED BRONZE BEARINGS

Stock No.	Shaft Diam.	Bolt Size	Net Wt.	L	W	H	C	A	B	D	F	G	X
9-500-5	1/2"	5/16"	7 oz.	3 21/32"	1 1/32"	1 31/32"	1 3/16"	2 13/16"	3/4"	7/16"	7/8"		1/2"
9-500-6	5/8"	5/16"	7 oz.	3 21/32"	1 1/32"	1 31/32"	1 3/16"	2 13/16"	3/4"	7/16"	1"		1/2"
9-500-7	3/4"	5/16"	7 oz.	3 21/32"	1 1/32"	1 31/32"	1 3/16"	2 13/16"	3/4"	7/16"	1 1/4"		1/2"

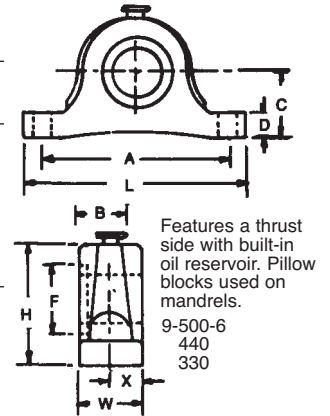

SINTERED BRONZE BEARINGS SELF ALIGNING

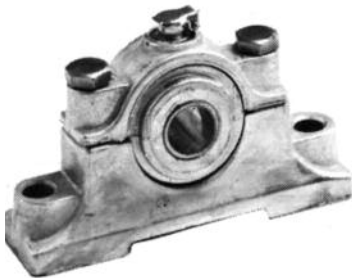

Stock No.	Shaft Diam.	Bolt Size	Net Wt.	L	W	H	C	A	B	D	F	G	X
7-500-5	1/2"	5/16"	8 oz.	3 21/32"	1"	2"	1 1/8"	3 1/16"	3/4"	2 1/32"	1 1/16"	1 1/32"	1/2"
7-500-6	5/8"	5/16"	8 oz.	3 21/32"	1"	2"	1 1/8"	3 1/16"	3/4"	2 1/32"	1 1/16"	1 1/32"	1/2"
7-500-7	3/4"	5/16"	8 oz.	3 21/32"	1"	2"	1 1/8"	3 1/16"	3/4"	2 1/32"	1 1/16"	1 1/32"	1/2"

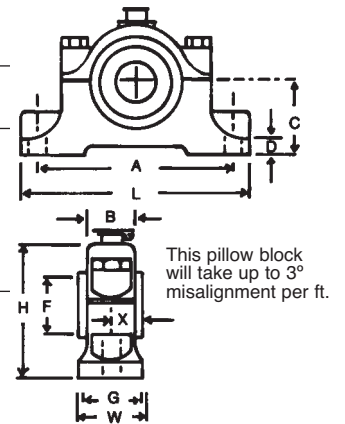

SINTERED BRONZE JOURNAL BEARINGS



Stock No.	Shaft Diam.	Bolt Size	Net Wt.	L	W	H	C	A
702	1/4"	3/16"	2 oz.	2 7/32"	3/4"	1 3/16"	7/16"	1 1/2"
703	5/16"	3/16"	2 oz.	2 7/32"	3/4"	1 3/16"	7/16"	1 1/2"
704	3/8"	3/16"	2 oz.	2 7/32"	3/4"	1 3/16"	7/16"	1 1/2"
705	1/2"	1/4"	4 oz.	3 1/32"	1"	1 1/16"	9/16"	2 1/32"
706	5/8"	1/4"	5 oz.	3 1/16"	1"	1 5/16"	3/4"	2 3/32"
707	3/4"	1/4"	5 oz.	3 1/16"	1"	1 5/16"	3/4"	2 3/32"

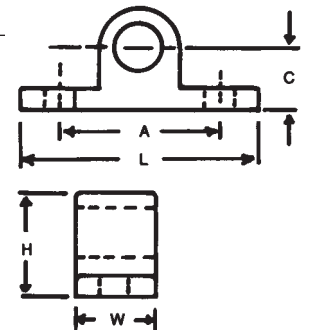

BALL BEARINGS CAST IRON HOUSING SOLID BASE



Stock No.	Shaft Diam.	Bolt Size	Net Wt.	H	L	J	A	N	N ₁	H ₁	H ₀	S	B
6-700-5	1/2"	3/8"	22 oz.										
6-700-6	5/8"	3/8"	22 oz.	1 3/16"	4 15/16"	3 25/32"	1 1/4"	1 5/32"	5/8"	1/2"	2 1/4"	1/4"	7/8"
6-700-7	3/4"	3/8"	22 oz.	1 5/16"	5"	3 25/32"	1 15/32"	1/2"	5/8"	9/16"	2 1/2"	9/32"	1"

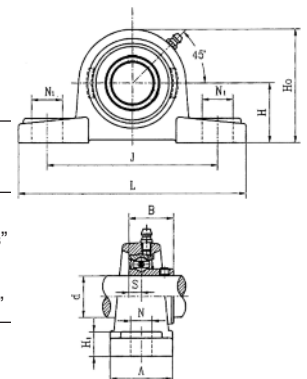

FLEXIBLE COUPLINGS SUPPLIED WITH HYTREL WASHERS

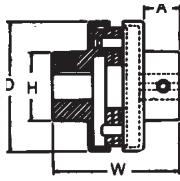

Stock No.	Leather Washers	Diameter of Bore				Net Wt.	H	A	D	W
		3/8"	1/2"	5/8"	3/4"					
110	LW110		•	•k	•k	8 oz.	1 1/4"	9/16"	2 1/8"	1 7/8"

KEYWAY DATA: Couplings indicated by (•k) are furnished with 3/16" x 3/32" keyways. Combination bores can be furnished at no extra charge.

All pulleys are furnished with hollow head set screws.

Crown Pulley

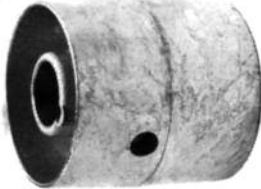

CROWN FACE PULLEYS

Stock No.	Outside Diam.	Width of Face	Bore Diam.				Net Wt. Ozs.
			1/2"	5/8"	3/4"	7/8"	
309	3"	3"	•k	•k	•k	•k	23
310	3 1/2"	3"	•k	•k	•k	•k	27
311	4"	3 1/2"	•k	•k	•k	•k	39

KEYWAY DATA: Bores indicated by (•k) have standard 3/16" x 3/32" keyways. Bores larger than 7/8" have 1/4" x 1/8" keyways.

DIE CAST HUBS

All hubs are furnished with hollow head set screws.

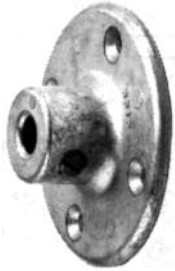

Stock No.	Out-side Diam.	Diameter of Bore						No. of Holes	Net Wt. Ozs.
		1/4"	5/16"	3/8"	1/2"	5/8"	3/4"		
2120	2 1/8"	•	•	•			3	2	
2121	2 1/2"			•				4	
2122	2 1/4"			•	•		4	5	
2123	3 3/4"				•	•	4	10	

HUBS

A	C	E	L	N
5/8"	1 1/16"	1/8"	23/32"	1/8"
7/8"	3/4"	3/16"		
1 5/32"	1"	5/32"	1"	3/16"
1 3/8"	1 3/8"	3/16"	1 1/4"	3/16"

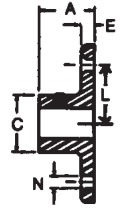

UNIVERSAL JOINTS

Universal joints can be furnished drilled or tapped at a slight increase in price with production quantities.

Stock No.	Bore Diam.	Out-side Diam.	Over-all Length	Length of Bore	Net Wt. Ozs.
4004	1/4"	9/16"	2"	9/16"	1 1/2"
4005	5/16"	9/16"	2"	9/16"	1 1/2"
4006	3/4"	1 3/16"	2 7/8"	7/8"	4"
4008	1/2"	1 3/16"	2 7/8"	7/8"	4"
4010	5/8"	1 1/8"	3 1/4"	1 5/16"	8"
4012	3/4"	1 1/8"	3 1/4"	1 5/16"	8"

DIE CAST FLANGES

For grinding or buffing mandrels.

Stock No.	Out-side Diam.	Diameter of Bore					Nt. Wt. Per Pair
		3/8"	1/2"	5/8"	3/4"	1"	
3	1 1/2"	•	•			3 oz.	
4	1 3/4"		•	•		4 oz.	
5	2 7/8"			•	•	10 oz.	

SLEEVE COUPLINGS

All couplings are furnished with set screws.



Stock No.	Bore Diam.	Out-side Diam.	Length	No. of Set Screws	Net Wt. Ozs.
5008	1/2"	1"	2"	2	2 1/2
5010	5/8" - 3/4"	1 3/8"	2 3/4"	4	8
5100*	1"	1 3/4"	3 1/2"	4	10



B	E
9/32"	1/4"
1/4"	1/4"
7/16"	3/8"
1/2"	7/16"



DIE CAST HAND WHEELS



Stock No	Out-side Diam.	Diameter of Bore			Net Wt. Ozs.
		1/4"	5/16"	3/8"	
9NK	1 1/2"	.	.	.	1 1/2
10NK	1 7/8"	.	.	.	2

A	C	E	F
1/2"	5/8"	5/32"	7/16"
1 1/4"	5/8"	3/4"	1"



Stock No	Out-side Diam.	Diameter of Bore				Net Wt. Ozs.
		1/4"	5/16"	3/8"	1/2"	
11NG	2"	2 1/2
12NG	2 1/2"	5

A	C	E	F
5/8"	3/4"	5/16"	1/2"
7/8"	1 1/8"	7/16"	1 1/16"

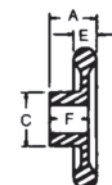

Stock No	Out-side Diam.	Diameter of Bore				Net Wt. Ozs.
		3/8"	1/2"	5/8"	3/4"	
183NR*	2 3/4"	5
184NR*	3 1/4"	8 1/2
185NR*	3 1/2"	10

A	C	E	F
1"	1 1/16"	3/8"	3/4"
1 1/16"	7/8"	7/16"	3/4"
1 1/8"	1"	9/16"	3/4"

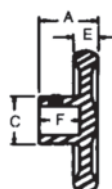

Stock No	Out-side Diam.	Diameter of Bore				No. of Spokes	Wt. Ozs.
		3/8"	1/2"	5/8"	3/4"		
186NS*	4 1/2"	4	14 oz.
187NS*	6"	3	1 lb. 10 oz.

A	C	E	F	G
1 1/4"	1"	5/8"	7/8"	2"
2 3/16"	1 3/8"	1 1/16"	1 1/32"	2 1/8"

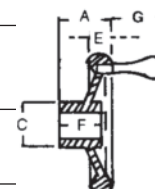

Stock No	Out-side Diam.	Diameter of Bore		Net Wt. Ozs.
		3/8"	1/2"	
19225	2 1/4"	.	.	4.5
19275	2 3/4"	.	.	5.5
19325	3 1/4"	.	.	6.5

A	C	E	F
1"	5/8"	3/8"	5/8"
1 1/4"	1 3/16"	3/8"	9/16"
1 1/4"	1 3/16"	1 3/32"	7/8"

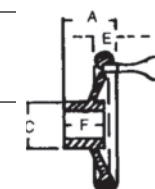

Stock No	Out-side Diam.	Diam. of Bore	Net Wt. Ozs.
14KN	1 1/8"	5/16"	1 1/2"

A	C	F
3/4"	5/8"	7/16"

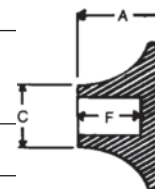

All handwheels indicated (*) are supplied with hollow head set screws. "NS" Series supplied with or without spinning handle. 19000 Series supplied with spinning handle.

MOTOR ARBOR ATTACHMENTS

BUFFING

Stock No. 604 R.H. thread only. Takes wheels 1/2" wide with 1/2" hole. Shank diameter 1/4" or 3/8". Shipping wt. 4 ozs.

Stock No. 606 R.H. or L.H. Thread. Takes wheels 3/4" wide with 1/2" hole. Furnished for 1/2" or 5/8" motor shaft. Shipping wt. 7 ozs. (carded for peghook display).



No. 604



No. 606

MANDRELS FOR FARM, HOME AND FACTORY



No. 440 SINTERED BRONZE BEARING
 Shaft Length 12"
 Shaft Diam. 5/8" Pulley Diam. 2"
 Threaded End 1/2" L.H. V-Belt Size "A" Sec.
 Shipping Wt. 3 lbs.

PACKAGED



No. 550 SINTERED BRONZE BEARING
 Shaft Length 9"
 Shaft Diam. 5/8" Pulley Diam. 2" X 2 1/2"
 Threaded Ends 1/2" R. & L. V-Belt Size "A" Sec.
 Shipping Wt. 2 1/4 lbs.

BUFFING MANDRELS



No. 330 SINTERED BRONZE BEARING
 Shaft length 12"
 Shaft Diam. 5/8" Pulley Diam. 2"
 Threaded Ends 1/2" R. & L. V-Belt Size "A" Sec.
 Shipping Wt. 3 1/4 lbs.



PRECISION BALL BEARINGS

No.	Shaft Length	Diam.	Threaded End	Wt.
1560	10"	5/8"	5/8" L.H.	3 lbs.

Pulley 2" "A" Sec.



No. 888 SINTERED BRONZE BEARING
 Shaft length 7 1/2"
 Shaft Diam. 5/8" Pulley Diam. 2"
 Threaded Ends 1/2" R. & L. V-Belt Size "A" Sec.
 Shipping Wt. 2 3/4 lbs.

WARRANTY AND DISCLAIMER

Chicago Die Casting Mfg. Co. ("CDC") warrants that all goods of its manufacture will meet the specification set forth in its catalog. CDC will, without charge, repair or provide a replacement for any of the products it manufactures which prove to be defective in either materials or workmanship within one(1) year from the date of shipping.

OTHER THAN THE EXPRESS WARRANTY CONTAINED IN THE IMMEDIATELY PRECEDING PARAGRAPH, CDC GIVES NO WARRANTY, EXPRESS OR IMPLIED, AS TO THE MERCHANTABILITY OR THE FITNESS FOR ANY PARTICULAR PURPOSE OF ANY GOODS IT MANUFACTURES. EACH PURCHASER OR USER OF GOODS MANUFACTURED BY CDC MUST MAKE HIS OWN DETERMINATION AS TO THE SUITABILITY OF SUCH GOODS FOR ANY PARTICULAR PURPOSE, AND MAY NOT RELY UPON ANY STATEMENT OR REPRESENTATION MADE BY CDC.

For a more complete explanation of the scope and limitations of CDC's Warranty, please refer to the terms and conditions accompanying the price list.

ORDER INFORMATION

For details on conditions of sales, please refer to our price list. Orders are given prompt delivery. We manufacture and stock the most complete line of high grade, low cost die cast fractional horse power transmission equipment in the nation.

Your request for samples, prices and literature covering our products will be given immediate attention.

In addition to our stock line, we manufacture high grade zinc castings for Original Equipment Manufacturers. Let us assist you in the construction of your product.

PLEASE NOTE: The specifications contained herein were in effect at the time this material was approved for printing. The Chicago Die Casting Mfg. Co. reserves the right to discontinue items, changes, specifications or design at any time. All items are designated for Fractional Horse Power use, unless otherwise specified.

$$\text{RPM} = \frac{\text{DIAMETER OF MOTOR PULLEY X RPM OF MOTOR}}{\text{DIAMETER OF DRIVEN PULLEY}}$$