

Forney

Metal-Working Products and Accessories Catalogue

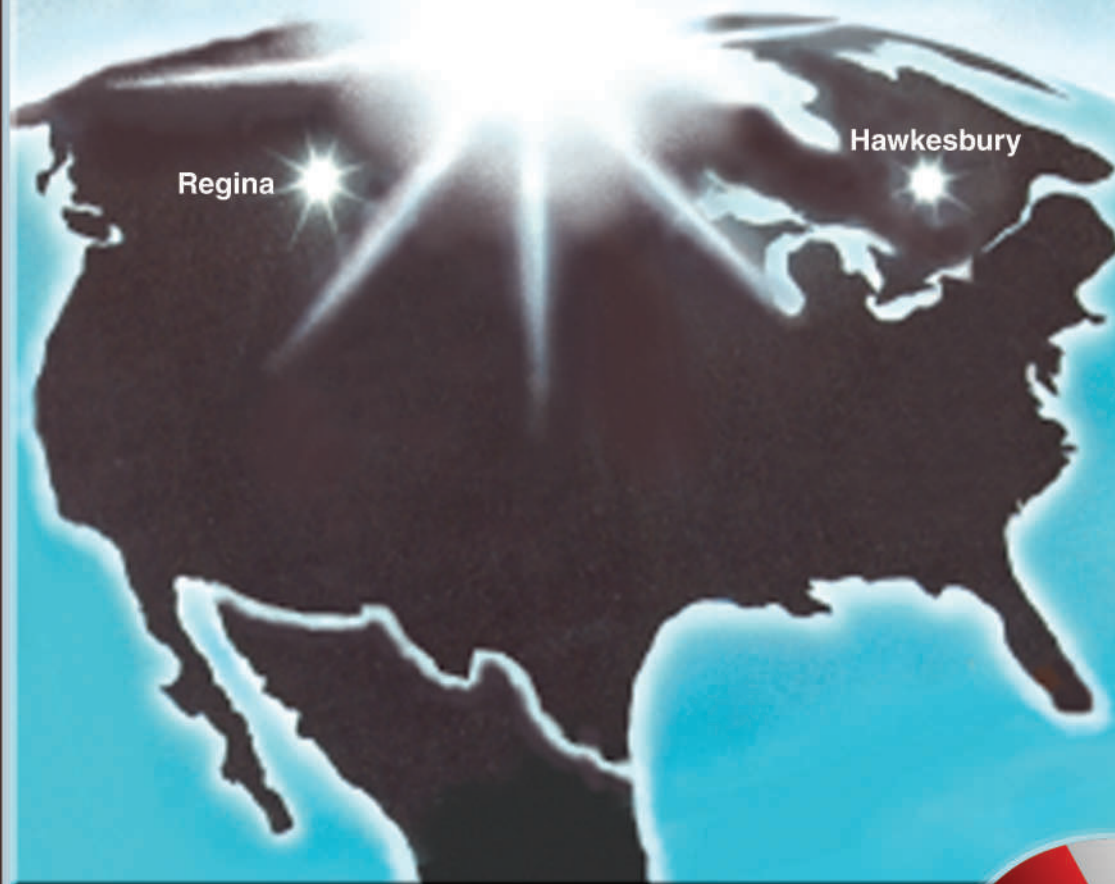

**June 2018
Revised**

Abrasives

Air Accessories

***Pressure Washer
Accessories***

Utility Hardware

Springs

Files

Gloves

Drill Bits

Hole Saws

Mig Wire & Solder

Jumper Cables

Micro-Abrasives

Safety Products

Welding

Accessories

Electrodes

Torches

Helmets





Welding and Metalworking Products & Supplies

Head Office

140 - 5th Ave. E.
Regina, Sask.
S4N 5A1
Phone: (306) 569-9083
Fax: (306) 565-3177

Eastern Warehouse

1375 Tessier Street
Hawkesbury, Ont.
K6A 3S6
Phone: (613) 632-2205
Fax: (613) 632-8152

DEALER CATALOGUE

Effective June 2018

Supersedes All Previous Catalogues and Supplements

----- TERMS AND CONDITIONS OF SALE -----

PRICES: Prices are subject to change without notice and prices in effect at the time of shipment will apply. G.S.T. will be charged in addition to the prices published in our Price List.

TERMS: Shipment will be on an open basis upon proper credit relations as determined by the Company. All billings are **NET 30 DAYS** from the date of shipment. Please pay from invoice.

TRANSPORTATION: Individual orders calling for shipment of \$600 or more (at dealer cost) will be shipped via **"Prepaid Freight"**. Orders less than \$600 will be shipped **"Freight Collect"** or **"Prepaid and Charge"**.

CANCELLATIONS: Shipper must receive notice 24 hours prior to shipment. Shipments executed and then cancelled will be treated as Returned Goods.

RETURN POLICY: Our Representatives do not work from warehouses and ARE NOT AUTHORIZED to pick up any merchandise. All returned goods are to be shipped to the Regina Warehouse via PREPAID FREIGHT. Any goods returned via COLLECT FREIGHT will have all applicable charges deducted from the overall credit. To assure proper credit and/or handling, please request prior authorization from the Regina Office before shipping the merchandise.

WARRANTY: Merchandise may not be returned for credit, replacement or warranty repairs unless authorized by the Regina Office. UNAUTHORIZED RETURNED GOODS OR COLLECT FREIGHT SHIPMENTS WILL NOT BE ACCEPTED FOR CREDIT.

CANCELLATION POLICY: All goods out of stock at the time of shipment will be cancelled and must be reordered by the customer. Only equipment and bulk/case lot items ordered and not shipped will be Back Ordered.

DAMAGED SHIPMENT - SHORTAGES: Claims for goods damaged or lost in transit will be directed to the Freight Carrier. The shipper's responsibilities end upon delivery of goods to the carrier. Any shortages on orders must be claimed for within **7 days** of receipt of goods by the purchaser.

OBSOLESCENCE POLICY: Returns will be accepted, freight prepaid, without a restocking charge if the items returned do not require repackaging. An offsetting order of equal value is required.

Any items that are less than standard pack, or items that require repackaging will be subject to a restocking charge.

SPECIAL ORDERS: "Special Order" product(s) not stocked by Forney are NON-RETURNABLE.



WELD ALL POLYETHYLENE REPAIR KIT

Plastic welder

Specifications

- Built for PE Type Welds
- Maximum Temperature 400°F/204°C
- Voltage 110/120 60 HTZ  Approved
- Grounded Double Insulated/
High Impact Plastic
- Longlife Nickel Plated/Corner Weld V-Tip
- Solid State



59030

Comes with:

30 ft Fusion Grade PE Thermoplastic Welding Wire # 59040

FUSION WELDS ALL: Ag Tanks, Chemical, Fuel, Water, Septic, Docks, Pontoon, Swath Rollers, ATV's, S/mobiles, M/bikes, Kayaks, Feeders, Wakeboards, Lawn/Garden Furniture & a whole lot more!

Easy to Use • All Purpose • Superior Adhesion • Fusion Grade Welding Wire • Sandable Welds

INSTRUCTIONS

- Remove damaged item from cold & windy conditions.
- Preclean damaged area. Rough sand surface of repair. Preheat welding gun for 10-15 minutes.
- Align & clip/tack/screw/wire/backup/reinforce damaged areas together. V-grind 7/8 the depth of the material single sided weld. Grind 1/2 & 1/2 for double sided welds, welding into newly welded bead on first side.
- Preheat damaged area to well above room temperature.
- Insert wire in preheat tube & allow wire to become molten. Place tip on crack & slowly proceed with repair. Thicker material requires a slower process and a double pass. Return to starting point, work weld in a circular motion, heating to a smooth glaze working weld into the substrate. Watch for pin holes when welding tanks.

USE EXTREME CAUTION:

- Fuel/Sprayer tanks can explode if leakage occurs on hot manifolds, electrical wiring, etc.
- To test all fluid tanks for pin holes, use water and air.

APPLICATIONS

- Specially formulated fusion grade welding wire has a high adhesion factor without a critical heat point!
- This universal welding kit can repair most polyethylene products on the market today including: green cross link chemical tanks, linear/low density/high density washer bottles, battery cases, holding tanks, household containers, fuel tanks, RV's, ATV's and much more.
- **Easy, do-it-yourself package.** **NOW** comes with 30 ft. of fusion grade (PE) polyethylene welding wire. This **Model** can weld all types of plastics with ease, such as: PE, PP, TPU, ABS, PVC, PC, TPO, etc.
- Use discretion and care, when using your plastic welder.
- Always place welder in safety stand. Keep work area clean.
- ***PLEASE NOTE: Keep welding tip clean at all times. Use drill bit for inside preheat tube and tip brush for total cleaning. Use fine sand paper to clean bottom of shoe for burnt on plastic. Keep from burning/charring your weld.**

PAINT MARKERS



70816

**70817 24 pc. ASSORTMENT
ONE QUART OPENING INVENTORY**
Contains the following items.

5 ea.	70818	WHITE
5 ea.	70819	BLACK
3 ea.	70820	RED
2 ea.	70821	BLUE
3 ea.	70822	YELLOW
2 ea.	70823	GREEN
2 ea.	70824	SILVER
2 ea.	70825	ORANGE

To refill displays, order by individual item number.

70818	WHITE
70819	BLACK
70820	RED
70821	BLUE
70822	YELLOW
70823	GREEN
70824	SILVER
70825	ORANGE

- Fast drying oil based paint.
- Precision valve action controls paint flow.
- Long bullet nib.
- 9/16" easy grip aluminum tube.
- 8 standard colors.

INDUSTRIAL PAINT MARKERS

Ideal for permanent marking and coding on a wide variety of surfaces, with excellent resistance to abrasion, water, sunlight and rough handling. Sold individually or in two convenient starter packages.

**70816 48 pc. ASSORTMENT
LARGE OPENING INVENTORY & DISPLAY
CONTAINS THE FOLLOWING ITEMS.**

10 ea.	70818	WHITE
10 ea.	70819	BLACK
6 ea.	70820	RED
6 ea.	70821	BLUE
6 ea.	70822	YELLOW
4 ea.	70823	GREEN
3 ea.	70824	SILVER
3 ea.	70825	ORANGE

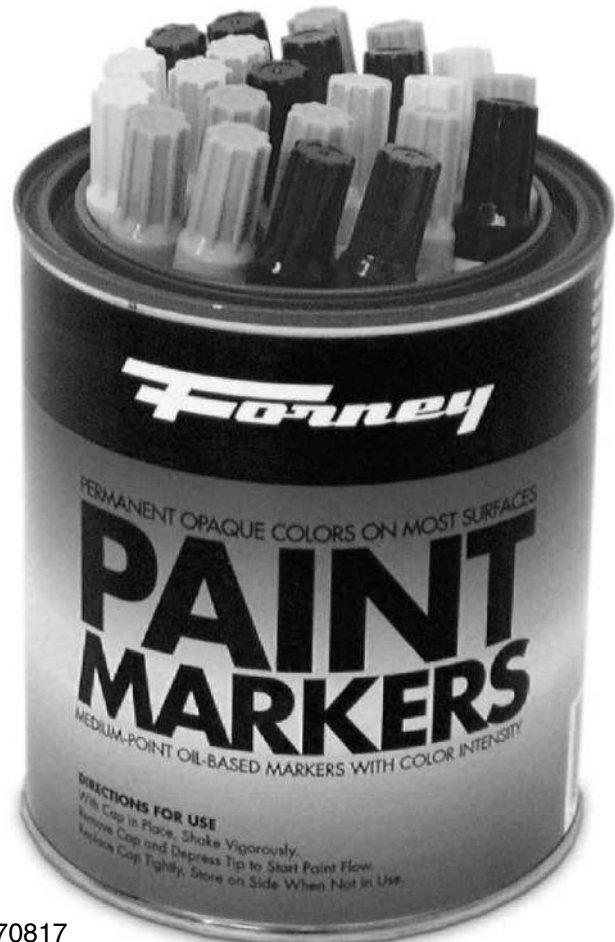

70817

POLY FLEX AIR HOSE

LIGHTER and FLEXIBLE

This hose weighs up to 50% less and is more flexible than rubber.

REPAIR IN THE FIELD

Hose Splicers Available for On - The - Spot Repairs. No Clamps Needed.



TANGLE FREE

Regardless of Environment, the Poly Flex Air Hose Remains Tangle - Free and Kink - Resistant.

WEATHER PROOF

The Temperature Range -40°F to 165°F Means This New Flex Hose Handles any Environment. (200psi @ 70°F)

MADE IN U.S.A.

AIR HOSE

TsP TOTAL SUPPORT PROGRAM

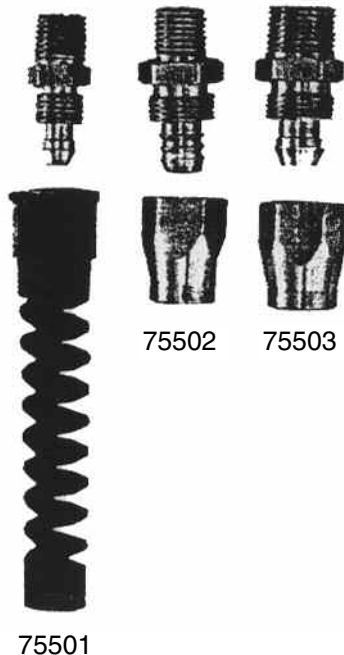

75442	1/4" x 50 FT. POLYFLEX AIR HOSE
75443	1/4" x 100 FT. POLYFLEX AIR HOSE
75444	3/8" x 50 FT. POLYFLEX AIR HOSE
75445	3/8" x 100 FT. POLYFLEX AIR HOSE
75450	1/4" x 25 FT POLYFLEX AIR HOSE ASSEMBLY
75451	3/8" x 25 FT. POLYFLEX AIR HOSE ASSEMBLY
75455	1/4" POLYFLEX AIR HOSE BULK.
75456	3/8" POLYFLEX AIR HOSE BULK.
75498	FLEX HOSE 1/4" SPLICER.
75499	FLEX HOSE 3/8" SPLICER.
75501	STRAIN RELIEF W / 1/4"
75502	3/8" ID x RIGID 1/4" MPT
75503	3/8" ID x RIGID 3/8" MPT

MIG WELDING EQUIPMENT & ACCESSORIES

85358 ARGON GAS REGULATOR KIT

For small to medium size Mig welders. Includes 85359 Adapter



85359 GAS LINE ADAPTER

For 85363 Argon/CO₂ Regulator & other mig systems with 1/8" gas hose (WE 6650)

85372 TORCH NECK WITH GAS DIFFUSER

(WE 6574). Only for Older Clarke Welders using 5/8" long Tips.



85376 TORCH NECK WITH GAS DIFFUSER

(WE7010) For Current Clarke Welders using 1" Long Tips



85377 WIRE LINER FOR TORCH NECK

(WE7012) For Current Clarke Welders using 1" Long Tips



WIRE LINERS FOR ALL MODELS OF 310, 312, 313, 315 & 316 CLARKE MIG WELDERS

6' Long. Teflon Recommended for Aluminum wire.

85355 Steel (WE 7001)



85336 TWECO NOZZLE (#21-50F) BORE SIZE 1/2" OR 12.7mm

1/2" gas concentration nozzle fits Tweco & Clarke style Mig guns and is suitable for medium duty applications.



85337 TWECO NOZZLE (#21-62F) BORE SIZE 5/8" OR 15.9mm

5/8" gas concentration nozzle fits Tweco style Mig guns. Suitable for medium to heavy duty applications.



85338 TWECO SPOTWELD NOZZLE BORE SIZE 5/8" OR 15.9 mm

5/8" spot welding nozzle can convert certain Mig welders into instant spot welders



85339 TWECO GAS DIFFUSER

Replacement gas diffuser efficiently disperses shielding gases for smooth, spatter-free welding on Tweco style Mig guns.



85333 BINZEL SPOTWELD NOZZLE BORE SIZE 5/8" / 16 mm

Handy 5/8" spot welding nozzle converts Mig welders into instant spot welders.



85378 NEW! TORCH NOZZLE WITH INSULATOR - BORE SIZE 7/16" (WE 6541)

For Current Forney/Clarke Mig welders



MIG WELDING EQUIPMENT & ACCESSORIES



60164



60165



60166



60167



60160



60161

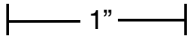

85346



85347



85348



85349

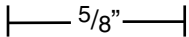

85369



85370



85371

HOBART MIG REPAIR PARTS

For Hobart Handler and Ironman Series Mig Welders.

12 / Bag	4 / Card	
85365	60164Contact Tip-.023/.025
85366	60165Contact Tip-.030
85367	60166Contact Tip-.035
85368	60167Contact Tip-.045

60160.....Nozzle - 1/2" (Hobart #770404, Miller #169-715)

60161.....Nozzle - 5/8" (Hobart #770405, Miller #169-726)

1" CONTACT TIPS FOR TWECO/BINZEL MIG GUNS & CURRENT CLARKE UNITS

Precision machined contact tips designed to replace either Tweco or Binzel gun tips. Each or 4 per card.

12 / Bag	4 / Card	Clark #
85346	60170	WE 6514.....Tweco or Binzel .023 (0.6mm)
85347	60171	WE 6515.....Tweco or Binzel .030 (0.8mm)
85348	60172	WE 6625.....Tweco or Binzel .035 (0.9mm)
85349	60173	WE 6525.....Tweco or Binzel .045 (1.2mm)

5/8" CONTACT TIPS FOR MOST OLDER STYLE CLARKE MIG GUNS

Precision machined contact tips are designed to replace Forney or Clarke Mig gun tips each or 4/card.

12 / Bag	4 / Card	Clark #
85369	60176	WE6539.....035 (.9mm)
85370	60177	WE6542.....023 (.6mm)
85371	60178	WE6543.....030 (.8mm)

85801• MIG PLIERS DOES SEVEN JOBS FOR MIG WELDING

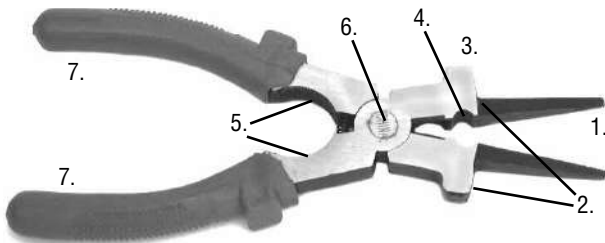

1. Needle nose pliers grip for pulling
2. Small serrated hole for mig tips
3. Flat surfaces for hammering
4. Cutter to trim mig wire
5. Large serrated hole for nozzle
6. Spring loaded handle
7. Heavy insulated comfort grip.

WELDING ELECTRODES



30681



30705



30686



30810

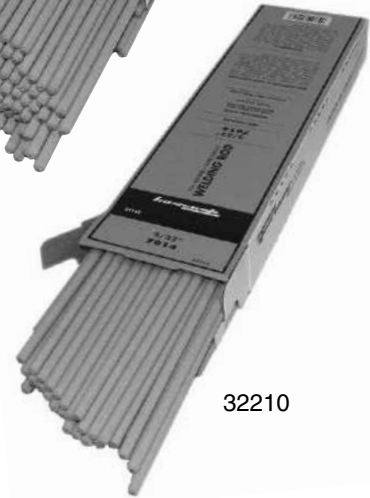

32210

6011 WELDING ELECTRODE (VERTICAL&OVERHEAD)

COLOR CODE: YELLOW LABEL- A mild steel, general purpose, all position electrode with stable arc characteristics and deep penetration. Use on AC or DC reverse polarity welding current. Fast freezing or rapid solidification of weld metal facilitates welding in vertical or overhead positions.

- High Penetrating, All Purpose Electrode
- Fence or Post Fabrication/Repairs
- Welding Through Medium Amounts of Paint, Rust, Dirt

Size	Catalogue # / pounds		
	1 lb.	5 lbs.	10 lbs.
3/32"	41101	31105	-
1/8"	41201	-	31210
5/32"	41301	-	31310

6013 WELDING ELECTRODE (GENERAL PURPOSE)

COLOR CODE: RED LABEL-A mild steel, general purpose, all position electrode. Use AC or DC (straight or reverse polarity) welding current. Especially useful for welding where poor fit-up conditions (wide gaps) exist. Small sizes are well suited for welding thin materials where low heat input required.

- Light to Medium Penetrating, All Purpose Electrode
- Ideal for Use on Weld Joints With Poor Fit-ups
- Use on Light Gauge Metal Sheet Metal and Duct Work
- For Metal Buildings and Structures

Size	Catalogue # / pounds		
	1 lb.	5 lbs.	10 lbs.
1/16"	40102	-	-
5/64"	40201	1/2 lbs.	-
5/64"	40202	-	-
3/32"	40301	30305	-
1/8"	40401	-	30410
5/32"	40501	-	30510

7014 WELDING ELECTRODE (HIGH DEPOSITION)

COLOR CODE: ORANGE LABEL- A mild steel, all position iron powder electrode. Designed to increase deposition rates and welding speeds. Provides good arc stability, low spatter and produces medium to low penetration. Can be used on AC or DC (straight or reverse polarity) welding current.

- Light to Medium Penetrating, All Purpose Electrode
- Use Where Higher Deposition Rates & Faster Travel Speeds Are Required
- For Heavy Sheet Metal
- Smooth, Fine-Rippled Bead Appearance

Size	Catalogue # / pounds		
	1 lb.	5 lbs.	10 lbs.
3/32"	42001	32005	-
1/8"	42101	-	32110
5/32"	42201	-	32210

WELDING ELECTRODES

FORNEY AC 7018 WELDING ELECTRODE

(High Strength - Low Hydrogen)

COLOR CODE: LIGHT BLUE & RED LABEL-A low hydrogen 7018 electrode designed for smaller 208/230 volt, single phase AC welders. Provides a smooth, stable arc. Has excellent restart capabilities. Designed for welding low, medium and high carbon steels and some higher strength low-alloy steels.

- Designed to Be Used With Smaller 208/230 Volt AC Welders
- Low Hydrogen Electrode For Low, Medium and High Carbon Steels

Size	Catalogue # / pounds		
	1 lb.	5 lbs	10 lbs
3/32"	40680	30681	-
1/8"	40684	-	30686
5/32"	40688	-	30690

- For Frames, Trailer Hitches and Chassis
- For High Strength (70,000 PSI Min. Tensile Strength) Welding Requirements

FORNEY 7018 WELDING ELECTRODE

COLOR CODE: PALE BLUE LABEL-A low hydrogen iron powder type electrode that produces X-Ray quality welds in all positions. Works best on DC reverse polarity welding

- Field Erections and Steel Structures
- For Frames, Trailer Hitches and Chassis
- Low Hydrogen Electrode For Low, Medium & High Carbon steel

Size	Catalogue # / pounds		
	1 lb	5 lbs	10 lbs
3/32"	40701	30705	-
1/8"	40801	-	30810
5/32"	40901	-	30910

- For High Strength (70,000 PSI Min. Tensile Strength) Welding Requirements

6010 DC WELDING ELECTRODE

(Deep Penetrating)

A mild steel, all position deep penetrating welding electrode. 6010 electrodes can only be used with direct current (DC) power sources. Especially useful for root welding passes that are located within a pipe. Deep penetration, with the ability to "dig" through rust, paint, oil and dirt.

- Deep penetration but with higher spatter
- For use with DC power source only
- For use with all types of steel under almost any conditions
- Electrodes must be stored in a dry location, at room temperature, and in a sealed container.

Size	Catalogue # / pounds	
	5 lbs	10 lbs
3/32"	31505	-
1/8"	-	31610
5/32"	-	31710

41000 MILD STEEL ROD DISPLAY RACK

Contains one package of each



CAT. #	DESCRIPTION
41101	6011 Electrode - 3/32" - 1 lb.
41201	6011 Electrode - 1/8" - 1 lb.
41301	6011 Electrode - 5/32" - 1 lb.
40301	6013 Electrode - 3/32" - 1 lb.
40401	6013 Electrode - 1/8" - 1 lb.
40501	6013 Electrode - 5/32" - 1 lb.
42001	7014 Electrode - 3/32" - 1 lb.
42101	7014 Electrode - 1/8" - 1 lb.
42201	7014 Electrode - 5/32" - 1 lb.
40684	7018 Electrode AC - 1/8" - 1 lb.

SPECIALTY ELECTRODES



SPECIALTY ELECTRODES

See pages 7-9 for Boxed Specialty Rods

Attractively packaged in plastic sleeves with zip locks to prevent moisture and dirt damage to the rod. Each package has specific, pertinent information and up to date safety warnings. Display Specialty Rods with Header Cat #10573. Opening Inventory Cat# 42680 (pictured at left).

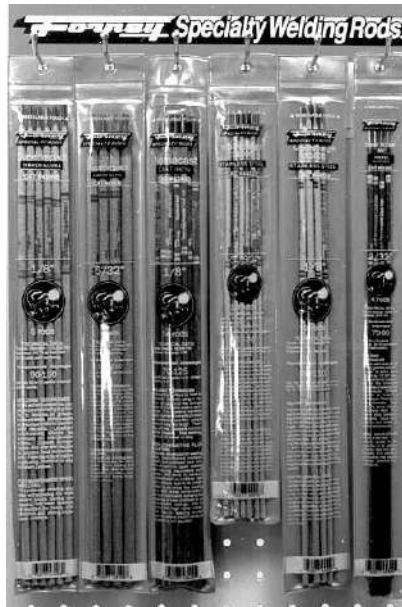

OPENING INVENTORY CAT# 42680

Cat.#	Description
42397	Supercote Hardfacing 1/8"
42801	Superwear 5/32"
43400	Nomacast 1/8"
44556	Stainless Steel 3/32"
44559	Stainless Steel 1/8"
45300	99% Nickel 3/32"
45460	55% Nickel 3/32"
45464	55% Nickel 1/8"
45889	DC Aluminum Arc 1/8"
46111	Easy Flo Aluminum 1/8"x18"
48571	Forney Super Sil-Flo 18"
45860	Super Blast Gouging 1/8"

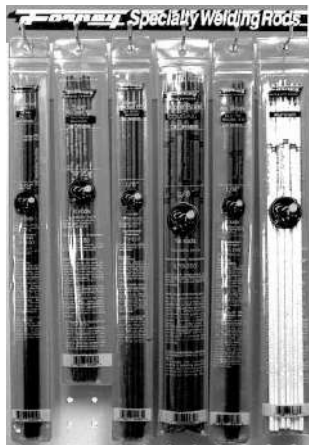

WELDING ELECTRODES AND ROD

SUPER A

Dia.	Amps	Cat. # 5 lbs.	Cat. # 1 lb.
1/8"	70-110	42405	42397
5/32"	70-110	42415	



SUPERBLAST GOUGING

Dia.	Amps	Cat. # 1 lb.
1/8"	60-110	45860

SUPER WEAR HEAVY ABRASION

Dia.	Amps	Cat. # 1 lb.
1/8"	60-110	45860

NOMACAST - A.W.S. ELECTRODES

Dia.	Amps	Cat. # 1/2 lb.	Cat. # 1 lb.	Cat. # 5 lbs.
1/8"	70-125	43400	43401	43405



SUPER NI-CAST 55% NICKEL

Dia.	Amps	Cat. # 1/2 lb.	Cat. # 1 lb.
3/32"	50-80	45460	45461
1/8"	70-110	45464	45465

SUPER NI-CAST 99% NICKEL

Dia.	Amps	Cat. # 1/2 lb.	Cat. # 1 lb.
3/32"	70-90	45300	
1/8"	80-120	45400	
1/8"	80-120		45401

SUPERCOTE A

Supercote is an excellent general purpose low cost hard surfacing rod for surfaces subjected to abrasive wear & impact.

SUPERBLAST GOUGING

Superblast gouging is ideal for chamfering, grooving, and cutting all ferrous metals using common welding equipment. Fastest method of removing unwanted metal.

Polarity: DC Straight or AC



SUPER WEAR HEAVY ABRASION

Super wear heavy abrasion is ideal for parts that require a high level of durability, because of high-impact and medium abrasion. Heat treatable.

Polarity: DC Reverse or AC

Hardness: RC 58-60

NOMACAST - A.W.S. Electrodes 1/8"

A non-machinable steel electrode designed to run at low amperage to repair cast iron. Use on cast parts that are not subjected to heating and cooling in normal use and where machining is not required. Tensile strength about twice that of a good grade of cast iron. Suitable for use on transmission housings, gear boxes and many other casting. May be used to join cast to other metals.

SUPER NI-CAST 55% NICKEL

ULTIMATE ELECTRODE FOR ALL CAST IRONS

The state - of - the - art coated electrode for welding every known grade of cast iron, heavy sections of thin, and for joining these cast irons to steel. The Computer Controlled Coating produces welds that represent the optimum balance between tensile strength and machinability

Typical Applications: Weld all GRADE 30 - 40 - 50 gray cast iron: ductile, nodular (spheroidal graphitic iron), malleable, Meehanite Engine blocks and diesel heads. Gear boxes, transmission housings, differentials. Machine bases and presses.

Tensile Strength: 70,000 PSI

Specifications: E NiFe-CI

SUPER NI-CAST 99% NICKEL

Features a non-conductive coating that is ideally suited for welding all grades of gray cast-iron - particularly thin sections and welds requiring the highest possible machinability.

Typical Applications: Includes automotive engine blocks, transmission and pump housings.

Polarity: DC Reverse

Hardness: BHN 155

Tensile strength: 55,000 PSI

ARC & ACETYLENE WELDING RODS



STAINLESS STEEL ELECTRODE

Size	Cat. # 1/2 lb.	Cat. # 1 lb.
1/8"	44559	44560
3/32"	44556	44557

ALUMINUM ARC ROD

Size	Cat. # 1/2 lb.	Cat. # 1 lb.
1/8"	45889	45890

SUPER SIL-FLO BRAZING ROD

Size	Length	Cat. # 1/2 lb.	Cat. # 1 lb.
1/8"	18"	48571	48572

EASY-FLOW BRAZING ROD

Size	Length	Cat. # 1/2 lb.	Cat. # 1 lb.
1/8"	18"	46111	46112



STAINLESS STEEL ELECTRODE (FOR WELDING ALL STEELS)

The absolute ultimate computer-engineered, high alloy electrode for welding every known grade of steel using every known stick electrode power source! The first truly AC-DC mineral-coated high alloy that can be used by anyone, regardless of prior welding experience. Superior combination of tensile strength and elongation. Arc so ionized you cannot short it out.

Tensile Strength: 128,000 PSI

Elongation: 32%

ALUMINUM ARC ROD (HIGHEST STRENGTH ALLOY FOR ARC & TORCH WELDING LOW ALLOY ALUMINUM). Universal electrode for welding all cast, wrought and extruded aluminum, and all aluminum alloys in all positions.

Typical Applications: Truck Beds, Bodies, and Frames. Loading Ramps and Docks. Pipe, Railing, Banisters, Stairs and Diamond Plate. Door & Window Frames & Supports. Irrigation Piping. Transmission Housings & Gear Boxes. Engine and Motor Blocks. Machine Bases and Supports. Bus Bars, Electrical Switch Boxes and Mounts.

SUPER SIL-FLO BRAZING ROD

Super sil-flo brazing rod is a brazing alloy that is ideal for large and small copper tubing installations. Self fluxing on copper.

Typical Applications: Refrigeration control valves (copper and brass), joining copper wires to rotor bars, electrical connections, radiant heating systems, air conditioning units, hot and cold water lines, and heat exchangers. T joints, swage joints and sleeves, couplings on return bends and condenser fittings.

Note: Sil-Flo is not recommended for ferrous metals such as iron or steel. It is only for copper base metals as an effective economical alternative to copper-silver alloy rods.

Tensile Strength: 40,000 PSI

Melting Point: 1200°F (649°C)

Copper: 92%

Phosphorus: 7.5%

EASY-FLOW BRAZING ROD

The easy flow brazing rod makes it simple to braze aluminum and zinc based metals with an oxy-acetylene or propane torch set-up. Great for repairs on irrigation pipes, carburetor bowls, aluminum boats, camper covers, lawn mower housings and casings (including aluminum magnesium). No flux is required.

Melting Point: 732°F (389°C)

GENERAL PURPOSE OXY/ACETYLENE WELDING ROD MILD STEEL

High Quality mild steel rod for repair of low carbon steels. Copper coated rod is .06 maximum carbon and .17 maximum manganese. Great all around rod for shop projects and maintenance projects for home or commercial use. 45,000 PSI Tensile Strength. 2700 F melting point.

Description	Cat. #	
1/16" x 36"	42330	5 lbs.
3/32" x 36"	42335	5 lbs.
1/8" x 36"	42340	5 lbs.

FLUX COATED BRAZING ROD (LOW FUMING BRONZE)

High Quality, low fuming bronze brazing rod with flux. Formulated for high tensile strength and ductility. Smooth flowing. Excellent for most brazing uses. Flux coated for best cleaning action. 65,000 PSI Tensile Strength. 1598° F melting point.

Description	Cat. #	
3/32" x 36"	48495	4 lbs.
1/8" x 36"	48504	4 lbs.
3/32" x 18"	48490	(10 Rods)
1/8" x 18"	48500	(10 Rods)



SOLDER AND FLUXES



LEAD-FREE SOLDER (Orange Labels)

Tin-Antimony "Lead-Free" solder can be used for soldering potable water pipe joints. Good for plumbing, refrigeration systems and other non-electrical applications where strength is required.

Cat. #	Grade	Tensile Strength	Melting Temp °F	Melting Temp °C	Wt.
38057	1/8" 95/5	6000	464	240	1/4 lb.
38061	1/8" 95/5	6000	464	240	1/2 lb.
38056	1/8" 95/5	6000	464	240	1 lb.



ROSIN CORE SOLDER (Blue Labels)

Ideal for electric wiring connections because its residues are non-conductive. Will not cause deterioration or malfunction of electrical connections.

Cat. #	Grade	Tensile Strength	Melting Temp °F	Melting Temp °C	Wt.
38070	1/8" commercial -		575	299	1 lb.
38071	3/32" 30/70	4500	491	255	1/2 lb.
38072	3/32" 40/60	4900	460	238	1/4 lb.
38073	1/16" 60/40	4900	390	198	1/4 lb.
88107	1/16" 60/40	6900	375	190	1/2 lb.
88108	1/16" 60/40	6900	375	190	1 lb.



ACID CORE SOLDER (Red Labels)

General purpose solder for sweat fittings, sheet metal joints, gutter work and other big jobs. Works well on galvanized sheet, copper, steel, nickel plate, brass and tin plate. **(NON ELECTRICAL)**

Cat. #	Grade	Tensile Strength	Melting Temp °F	Melting Temp °C	Wt.
38101	1/8" commercial -		575	299	1 lb.
38102	1/8" 30/70	4500	491	255	1/4 lb.
38103	1/8" 95/5	4900	460	238	1/2 lb.



SOLID WIRE SOLDER (Green Labels)

For general use with appropriate type flux such as Forney FireEater #38127, Paste Flux #38128. 50/50 is popular for radiator repair. **(Not for Aluminum)**

Cat. #	Grade	Tensile Strength	Melting Temp °F	Melting Temp °C	Wt.
38114	1/8" commercial -		575	299	1 lb.
38111	1/8" 30/70	4500	491	255	1/2 lb.
38108	1/8" 40/60	4900	460	238	1/4 lb.
38109	3/32" 50/50	5500	421	216	1/4 lb.
38110	1/8" 50/50	5500	421	241	1/2 lb.

FLUXES, GEL AND ANTI-SPATTER SPRAYS



37028

37028 COLD GALVANIZING COMPOUND (76245)

High quality Spray Galvanizing Compound provides exceptional surface protection from rust and corrosion and is specially formulated for easy spraying. 13 oz. can



37029

37029 ANTI-SPATTER POWDER (76243)

Provides protection from weld spatter and Mig gun stick up. For users who prefer the convenience of a dry powder over liquids and gels. Often preferred because it is visible where applied. 11-1/2 oz. can



37030

37030 ANTI-SPATTER LIQUID (76249)

Eliminates welding spatter from the welding zone, mig nozzles, contact tips & surfaces where spatter is objectionable. 16 oz. can



37031

37031 FORNEY NOZZLE GEL

Gel eliminates erratic operation with a film that will not clog orifices and threads. Suitable for use on fixtures of semi and automatic welders. Odorless, non-flammable, non-toxic and silicone free. Will not cause porosity. 16 fl. oz.

MIG WELDING WIRE

MIG WIRE (E70S-6)

Ideal for auto body repair and light fabrication on most thin metals. Contains a higher level of manganese and silicone for a superior weld even on rusty, dirty steel. Produces a smoother bead which requires less grinding. Argon CO2 mix gas shielding required. Use DC reverse polarity. 70,000 PSI Tensile Strength.

Diameter	2-lbs.	10-lbs.	30-lbs.	44-lbs.
.023	42290	42285	42275	
.030	42291	42286	42276	
.035	42292	42287		44281
.045				44282



SELF SHIELDING MIG WIRE (E71T-GS)

Self-Shielding all Position Flux Cored Welding Wire. Single pass applications. Excellent for use on thin gauge mild steel High travel speed Low spatter No shielding gas required 70,000 PSI Tensile Strength Use DC (straight polarity)

Diameter	1-lbs.	2-lbs.	10-lbs.
.030		42300	42301
.035	42304	42302	42303

42298 (308ER) STAINLESS STEEL MIG WIRE

Welds type 301 302 304 308 321 & 347 stainless steels. Applications: Food & Beverage Industry, Maintenance and Repair. Contains 20% Chromium, 10% Nickel. Argon or Argon/CO2 gas shielding required. 85,000 PSI Tensile Strength.

4043 ALUMINUM MIG WIRE

Features 5% Silicon content and a bright finish. Flows freely at 1155° F (624°C).

Typical Applications: For truck bodies, pressure vessels, and structural members. Dark gray color-coded label.

Tensile strength: 33,000 PSI
Polarity: DECP Reverse
Shielding Gas: Argon

5356 ALUMINUM MIG WIRE

Features 5% Magnesium content and a bright finish. Flows freely at 1180° F (637.8°C).

Typical Applications: Diesel engine bases, truck frames, cargo tanks, and gun mount bases. Light gray color-coding on label.

Tensile strength: 63,000 PSI
Polarity: DECP Reverse
Shielding Gas: Argon

4043 ALUMINUM

Dia.	Weight	Cat. #
.030"	1 lb.	42295
.035"	1 lb.	42296

5356 ALUMINUM

Dia.	Weight	Cat. #
.030"	1 lb.	42293
.035"	1 lb.	42294

RECIPROCATING SAW BLADES



MK MORSE MASTER COBALT BIMETAL RECIPROCATING SAW BLADES

39868 (RBMC618T25) - 6" - 18 T, 25/pkg.

39877 (RBMC818T25) - 8" - 18 T, 25/pkg.

- Smoother, more accurate cuts
- Conventional shanks to fit all standard reciprocating saws
- Wide variety of sizes for almost every professional need
- Cobalt edge welded to high strength steel backer for greater wear resistance and longer life
- 25 blades per pack



39749 RECIPROCATING SAW BLADE

ASSORTMENT WITH STORAGE CASE - 12 pc.

Includes 5 different blades plus a **BONUS STORAGE CASE**.

These blades are top quality industrial blades made in the USA that can be used on everything from rough framing to fire and rescue activities. These blades are manufactured in the world's most advanced saw blade manufacturing plant using processes that have been developed, improved and refined over years to produce safe, long lasting blades.

The kit includes:

- 4 pcs. - 6" x 18 TPI Cobalt Metal Cutting Blades** which can be used on metal, wood, nail embedded wood, composites, plastic and rubber.
- 2 pcs. - 9" x 14 TPI Cobalt Metal Cutting Blades** which can be used on metal, wood, nail embedded wood, composites, plastic and rubber.
- 2 pcs. - 6" x 10 TPI Real McRipper Demolition Blades** which can be used on general demolition work, wood, nail embedded wood, roofs, walls, metal studs, wallboard, plaster and lathe.
- 2 pcs. - 9" x 10 TPI Real McRipper Demolition Blades** which can be used on general demolition work, wood, nail embedded wood, roofs, walls, metal studs, wallboard, plaster and lathe.
- 2 pcs. - 6" x 14 TPI Fire and Rescue Blades** which can be used on machinable metal used in vehicle extraction and demolition.

WELDING ACCESSORIES

93097 14-3/8" DELUXE STORAGE CAN

Made of high impact polypropylene plastic. Tight Sealing Screw type cap and rubber O-ring- provide clean, dry, air-tight storage for electrodes. Store up to 10 lbs. of Forney 3/32", 1/8", 5/32" electrodes in 12" & 14" lengths in four convenient compartments.



59021 SOLDERING IRON* 30 WATT/110V

For Fine Wiring, Hobbies: Models, Making Jewelry
Electronics: TV's, Radios, Stereos, Games and Toys

** Comes in Clamshell Packaging*



59021

38059 LIQUID FLUX



38059

38116 SOFT SILVER SOLDER KIT

Five percent silver content. Self fluxing. Comes in plastic dispenser tube to protect from dirt, & moisture. Can be used on stainless steel, copper, brass, nickel alloys, nickel and chrome plated metal and iron. Stays bright & hard. Harmless in contact with food. Nontoxic. Joint strength up to 20,000 PSI Tensile Strength. (Working temperature up to 1,100° F). Application Temperature 400° F to 700° F

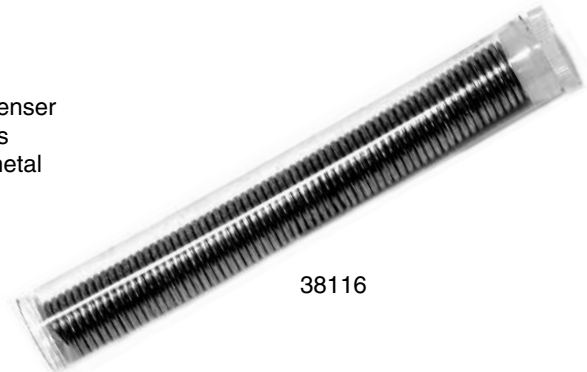

38116

SPEEDYBOND AND J-B WELD

SOLDERING FLUX

For soldering and tinning.

Plumbers, workers in brass, copper, tin, steel & stained glass will achieve superior results with these easy to use products. Produce strong, neat, durable joints. Rubyfluid allows solder to flow in a thin film. Adheres quickly and stays where its applied. Available in paste or liquid.

60301.....	3.5 fl. oz.
38125	PASTE 2 oz.
60303.....	PASTE 2 oz.



60301



38125

SOLDERING FLUX BRUSH

Tinning brush for liquid or paste flux.

38141.....	Brush (1GROSS)
60300.....	Brush (3/skin-packed)



60300

- 42260 SPEEDYBOND for Steel Opening Inventory (12 x 42267)
- 42262 SPEEDYBOND for Plastic Opening Inventory (12 x 42269)
Similar texture as clay. Ideal to repair metal and plastic articles, split or broken. Quickly dries; industrial force.
- 42267 Steel tube by unit 42269 Plastic tube by unit
Display tray # 10399 - free if you order the opening inventories 42260 and 42262.

42260



- 38063 J-B STICK EPOXY PUTTY STICK • for Steel 2 oz.
- 38064 J-B QUICKWELD • Two tubes of 1 oz. skin pack
J.B KWIK is great for hobby or craft projects household and auto repair. Cures in 4 minutes. Withstands temperatures to 300° F.
- 38065 J-B WELD • Two tubes of 1 oz. skin pack
- 38066 J-B INDUSTROWELD • Two tubes of 5 oz.
- 38067 J-B WATERWELD • One tube of 2 oz. skin pack
For repairs to water lines & containers etc.
- 38068 J-B KWIK • Two tubes of 5 oz.
- 38069 J-B MARINEWELD • Two tubes of 1 oz. skin pack
Waterproof, weatherproof, non-corrosive, withstands grease, petro-chemicals and high temperatures to 600° F. Many marine uses fixing deck gear, gally equipment, engines, masts and hulls.



38065



38066

MIXES LIKE PUTTY, BONDS LIKE EPOXY, HARDENS LIKE STEEL



ELECTRODE HOLDERS

ELECTRODE HOLDERS

Brass Bodies, Fiberglass Covers and Triggers Provide Excellent Conductivity and User Protection. Holders Insulated for Safety and Maximum Operator Protection. Grooved Jaws allow Electrodes to be used at Different Angles for Greater Operator Comfort & Efficiency.



56000

56000 TYPE F-2 200 AMP HOLDER

Designed for up to 5/32" rods. Widely used in steel fabrication. Will accept up to #2 welding cable. 8-1/2" length.

56200 TYPE F-3 ELECTRODE HOLDER 300 AMPS 10-1/2" LONG

Heavy-Duty Electrode Holder. Suitable for most arc welding jobs. Accommodates rods 3/32" through 3/16" diameter. Will accept up to #2 welding cable.



56200

56205 SCREW TYPE ELECTRODE HOLDER 400 AMP HOLDER

A quarter turn of its handle locks the jaws tight on the rod. No slip easy grip handle. Brass body with oval point screw for positive contact of cable and handle. Vulcanized fiber insulators designed for longer wear. Holds rod from 3/32" to 3/16" diameter. Will accept up to # 2 welding cable. 8-1/2" length.



56205

WELDING EQUIPMENT AND ACCESSORIES

STEEL GROUND CLAMPS

Rugged, Economical Ground Clamps for Shop, Maintenance and Fieldwork.

54410 STEEL GROUND CLAMP 300 AMP

Good positive connection. 1-3/4" wide jaw openings. 8" long. Suitable for all farm and shop welders. #2 cable capacity.



54510 STEEL GROUND CLAMP 500 AMP

For extra heavy jobs. Capacity to 500 Amps. Fine for good grounds on steel plate, angle iron, pipe, etc. 2-1/4" jaw opening. 9-1/2" long. #1/0 cable capacity.

BRASS GROUND CLAMPS

Large Contact Area of These Clamps Assures Positive Grounding. Oval-point Screw Cable Connections make Installation Easy, Assuring Good, Safe Cable Connections. Shim Stock Provided.

54300 BRASS GROUND CLAMP 200 AMP

Wide grooved jaws for positive ground. For medium-duty use. 1 1/2" jaw opening. 5" long. #2 cable capacity.



54400 BRASS GROUND CLAMP 300 AMP

Wide grooved jaws for positive ground. For medium-duty use. 1 1/2" jaw opening. 5" long. #2 cable capacity.



54405 BRASS GROUND CLAMP TWECO STYLE 500 AMP

Rugged, versatile, wide jaw ground clamp. Good for most grounding situations. Large contact surface area provides good cable connections and positive grounding. 2" jaw opening. 8" long. #1/0 cable capacity.



WELDING CABLE & ACCESSORIES



FORNEY WELDING CABLE

Highly flexible welding cable manufactured with 30 gauge fine stranded, soft drawn electrolytic copper for maximum conductivity. Vinyl (not paper) sheath separates copper from outer nitrile rubber sheath for super flexibility. Will not kink—even in cold weather. Outer sheath has excellent oil, water and abrasion resistance. Rated at 600 volts. Operating range of -30°F to 150°F. Sequentially marked by the foot, eliminating the need to “floor” measure the cable in the store.

Cat. #	Cable Size	Length
52010	Welding Cable #1/0	By the foot
52016	Welding Cable #1	50'
52017	Welding Cable #1	100'
52018	Welding Cable #1	150'
52019	Welding Cable #4	50'
52020	Welding Cable #4	125'
52021	Welding Cable #4	250'
52023	Welding Cable #2	50'
52024	Welding Cable #2	125'
52025	Welding Cable #2	250'
82020	Welding Cable #2/0	By the foot

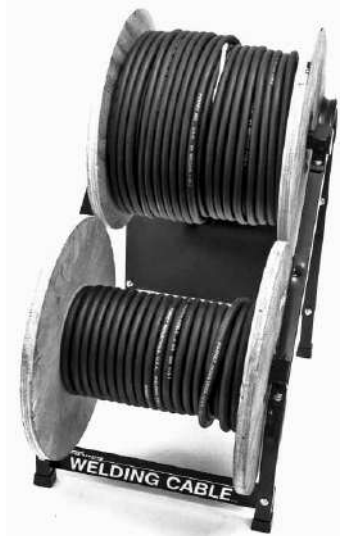

CABLE SELECTION GUIDE					
AMPS	0 - 50'	50 - 100'	100 - 150'	150 - 200'	200 - 250'
100	6 Awg	4 Awg	2 Awg	2 Awg	1 Awg
150	4 Awg	4 Awg	2 Awg	2 Awg	1 Awg
180	4 Awg	4 Awg	2 Awg	2 Awg	1 Awg
200	4 Awg	2 Awg	2 Awg	1 Awg	1-0Awg
225	4 Awg	2 Awg	1 Awg	1 Awg	1-0Awg
250	2 Awg	2 Awg	1 Awg	1 Awg	1-0Awg
300	1-0Awg	-	1-0Awg	-	1-0Awg

CABLE CONNECTOR (PAIR)

Camlock quick connectors for welding cable extensions.

- 57710 - Heavy Duty.....#1 - #4 Welding Cable
- 57715 - Heavy Duty.....#1/0 - #2/0 Welding Cable
- 57715M - Male End Only for 57715



ARC WELDER REPAIR PLUGS & ACCESSORIES

FEMALE REPAIR JACKS FOR FORNEY WELDERS

Includes fiber washers & retainer knobs. Fit Models C, CB, FS & F Series Forney Welders.

57510with black retainer knob
57511with red retainer knob
57512with black retainer knob for Miller Welders
57513with red retainer knob for Miller Welders
57501red retaining knob only (Forney)
57502black retaining knob only (Forney)

57512 FITS MILLER

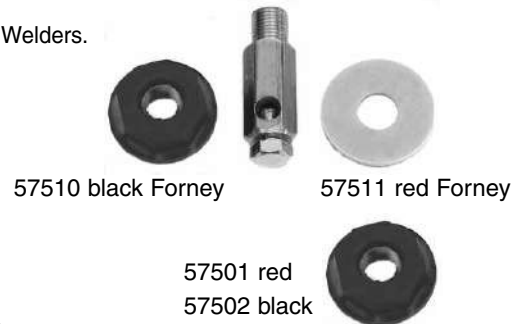

MALE SURE GRIP PLUGS FOR CABLE EXTENSIONS AND BUMPER JUMPER BOOSTER (SEE BELOW)

For assembly or replacement of welding cables #6 to #2. Makes mechanical connection with no soldering. Good for special connecting applications, light to heavy duty. Use on C, CB, FS & F series Forney & Miller welders. Complete with machined solid brass bar stock male plug, insulator sleeve, shim & set screw.

57901With black Insulator Forney 3/8"
57902With red Insulator Forney 3/8"
57903With black Insulator (Miller/Spitfire 5/16"
57904With Red Insulator (Miller/Spitfire 5/16"
57912Male Plug Fits Comet Welder
57915Male Plug W / Insulator for LKS Welders

57901 black
57902 red



FEMALE SURE GRIP PLUG

For assembly or replacement of welding cables and extension cables #6 to #2. Makes mechanical connection with Male Sure-Grip Plugs. Black insulators only.

57701/57700Accepts 57901 & 57902 (Forney)
57702/57703Accepts 57903 & 57904 (Miller/Spitfire)
57913Female Plug W / Insulator Fits Comet Welder
57920Female Plug W / Insulator for LKS Welders fits 57915

57700 red
57701 black
57702 black
57703 red



57705 SPLICER FOR #2 - #6 CABLE

For permanently splicing damaged or broken cables & adding additional cable length to existing welding cable leads.

57705 black



52841 BUMPER JUMPER

Mount between bumper & service unit battery. Use with male Sure-Grip Plugs (57901 & 57902) on bumper plate end of jumper cables. Starts cars, tractors, trucks with dead batteries in a breeze. Excellent for service stations, auto dealers, garages, trucking firms, contractors, farmers, ranchers. Kit includes output jacks, retaining knobs, insulating washers & bumper plate.

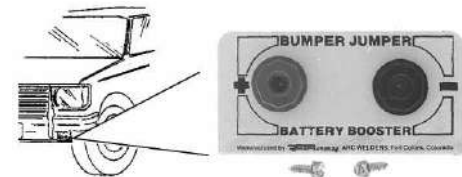

FORNEY WELDER REPAIR PARTS

54101Capacitor, 370V 20mfd (C & F Series)	50409Fan Motor Only (F-Series)
59300Welder On-Off Switch (60A/240V)	50411Fan Blade Only (for 50409)
59302Welder On-Off Switch (40A/250V)	50412Fan Blade Only (for 50408)
50408Fan Motor Only (SL-Series)		

CABLE ENDS SPLICERS & BUMPER JUMPER



CABLE LUGS & BUTT CONNECTORS

CABLE TERMINAL LUGS AND BUTT CONNECTORS

Premium all-copper cable lugs, carefully engineered and manufactured for sound, solid connections and trouble free service. Easily crimped and/or swaged. Made from electrolytic copper rated for 100% conductivity.

CABLE LUG KITS

- 57639.....Display Tray Only for 57640 / 57641
 - 57640*.....(57645 to 57656) Total of 104 Lugs
 - 57641.....(57645 to 57656) 1 ea. of 12 Lugs
 - 57642.....Display Tray Only for 57643
 - 57643.....New Lug/Butt Connector Assortment with Tray 57657 to 57668 (5 ea. = 60 Total)
- *Kit includes a display tray with an assortment of 4 to 16 #57645 to 57656. See below.

- 60088.....Cable Lugs & Connectors Inventory
- 60089.....Cable Lugs Opening Inventory

INDIVIDUAL CABLE LUGS

Individual Cat#	Skin Pack Cat # (Packed in prs.)	No. Incl. in kit #57640	Cable Size	Stud Size
57645	60090	12	8	#10
57646	60091	12	6	1/4"
57647	60092	16	4	5/16"
57648	60093	16	4	3/8"
57649	60094	12	2	5/16"
57650	60095	6	1	3/8"
57651	60096	6	1/0	3/8"
57652	60097	6	1/0	1/2"
57653	60098	6	2/0	3/8"
57654	60099	4	2/0	1/2"
57655	60100	4	3/0	1/2"
57656	60101	4	4/0	1/2"
57657	60102	5	8	3/8"
57658	60103	5	6	3/8"
57659	60104	5	4	1/2"
57660	60105	5	2	3/8"
57661	60106	5	2	1/2"
57662	60107	5	1	1/2"

BUTT CONNECTORS

57663	60108	5	8
57664	60109	5	6
57665	60110	5	4
57666	60111	5	2
57667	60112	5	1/0
57668	60113	5	2/0

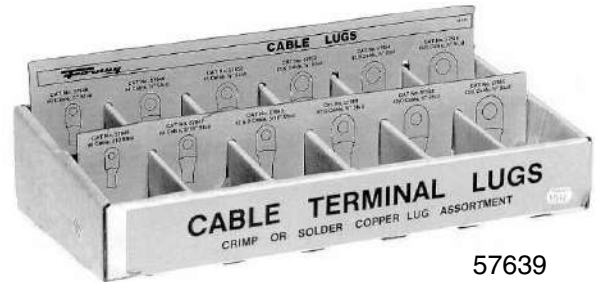

57639



Cable Lugs



Cable Lugs



Butt Connectors

WELDER PLUGS, RECEPTACLES & ACCESSORIES



57300 Pocket Size Digital Multimeter

- 7 functions...16 measuring ranges
- Test: DC Voltage, DC current, Resistance, Batteries, Diodes, Tests Audible Continuity and Transistors
- Single knob function switch
- Test Leads
- Nine volt battery included
- Complete instructions inc

57301 Pocket Size Multimeter

- 5 functions, 14 measuring ranges, test leads
- Compact, replaces cumbersome meters
- Wide open dial, clear markings
- Measures AC, DC and resistance
- Self contained resistance battery inside back cover
- Complete instructions included



50 AMP 230 VOLT MALE PLUGS & FEMALE RECEPTACLES

For Welders, Electric Stoves, Dryers, Table Saws and 220 V Power Equipment

Opening Inventory 57598

(1 Ea. 57601, 57602, 58400, 58401, 58402, 58499)
10501 P - O - G (Free) 6 ea. 10232 (free)



57601

57602

58499

58402

58400

58401



BRAZING CARBONS

Made with a central core of specially selected materials to give a steadier, quieter arc on alternating current than solid carbon electrodes. Ideally suited for welding and brazing.

Cat. #	Size	Carbons Per Card
60313	5/16" diameter x 6" long	2
60315	1/2" diameter x 6" long	2

OXY-ACETYLENE ACCESSORIES



86102 SINGLE FLINT STRIKER

Our most popular model. Features a square hood and round file with a patented assembly. Dependable. Light weight. Low cost

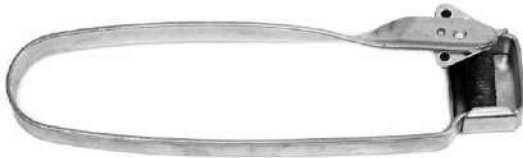

86103 THREE FLINT STRIKER

Quality tool. Rugged frame. Three large flints. Long lasting round file and brite plated finish. Dependable ignition under all working conditions. Release slotted screws to rotate new flint into position.



86104 THREE-FLINT REPLACEMENT STRIKER FLINTS

Three way rotating flints. Package of Four. Total of twelve flints skin packed on card. Fit most three flint lighters and Forney 86103 Three Flint Lighter.

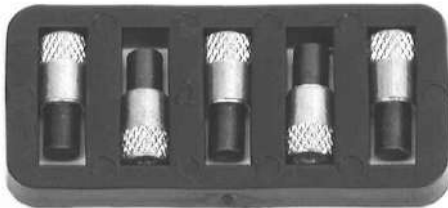

86122 SINGLE REPLACEMENT STRIKER FLINTS

Fit all standard screw-on type lighters and Forney 86102 Single Flint Lighter. Renewal flints easily installed.



86119 LONG TIP CLEANER KIT

Similar to Forney 86120. Extra long cleaners. Tip Cleaner Kit provides as many as 60 or more cleaning edges per inch of cleaner. Fits all tip sizes. Light and easy to use. Contains 13 sizes-6 through 26. Aluminum case includes dressing tool.



86120 STANDARD TIP CLEANER KIT

Tip Cleaner Kit provides as many as 60 or more cleaning edges per inch of cleaner. Fits all tip sizes. Light and easy to use. Contains 13 sizes-6 through 26. Aluminum case includes dressing tool.



86140 TIP DRILL SET (EXTRA BITS STORED IN BARREL)

12 tip drills within a pencil style design, with pocket clip. Used to clean and true most standard orifices of acetylene welding and cutting tips.

OXY-ACETYLENE ACCESSORIES



86101



88066

OXY-ACETYLENE HOSE ASSEMBLIES (GRADE R)

Forney quality Acetylene twin welding hoses complete with fittings. Kink proof for safety & service. Flexible yet strong enough to supply a 4:1 safety factor for welding applications. Neoprene covers. Rated at 100 PSI.

Cat. #	Hose Type	Length
86101	3/16" Hose Set	20'
86113	3/16" Hose Set	25'
86109	3/16" Hose Set	50'
86145	1/4" Hose Set	25'
86146	1/4" Hose Set	50'

88066 PLUMBERS TORCH HOSES

A-fittings for Forney and similar kits. 12-1/2'

HOSE NUTS* "B" FITTING, 9/16"

86124.....	Acetylene
86125.....	Oxygen



HOSE FERRULES* OXY-ACETYLENE

86126.....	3/16"
86135.....	1/4"



HOSE BRACE* OXY-ACETYLENE

86127.....	3/16"
86136.....	1/4"



BARBED HOSE NIPPLES* OXY-ACETYLENE

86128.....	3/16"
86137.....	1/4"



HOSE COUPLERS*

"B" FITTING, 9/16-18THD FOR 3/16" & 1/4" HOSE. Allows user to increase the length of their hose for hard-to-reach places.

86129	Oxygen
86130	Acetylene
86131	3/16" Hose Splicer
86138	1/4" Hose Splicer



OXY-ACETYLENE ACCESSORIES

- 86148** Regulator Flashback Arrestors
86149 Torch Flashback Arrestors



86148

86149

OXY-ACETYLENE QUICK-CLIC CONNECTORS

Quick couplers for instant removal and storage of valuable cutting heads and torch attachments.

- 87155** - Torch To Hose
87156 - Hose To Hose
87157 - Regulator To Hose



87155

87156

87157

CHECK VALVES (Sold as pairs only)

87147 • REVERSE FLOW HOSE TO TORCH

Prevents gases from mixing in hoses; a common cause of explosions, fires & lost time injuries. Can be used in all Class B connections (9/16-18) even if fuel gas pressure is only 4 ounces. Fit between hose & torch.

87151 • REVERSE FLOW REGULATOR TO HOSE

Prevents gases from burning through regulators to tanks leading to extreme damage, explosions, fires, personal injury & property damage. Fit between regulator outlet and Hose.

87147



87151



REGULATOR FITTINGS

- 87731** OUTLET CONNECTION (OXYGEN)
87732 OUTLET CONNECTION (ACETYLENE)



87731

87732

- 87733** INLET NUT (OXYGEN) CGA 540
87734 INLET NUT (ACETYLENE) CGA 510



87733

87734

- 87735** INLET SWIVEL, OXYGEN CGA 540
 1/4" NPT
87736 INLET SWIVEL, ACETYLENE CGA 510
 1/4" NPT



87735

87736

OXY-ACETYLENE HOSE REPAIR KITS

86139 OXY-ACETYLENE HOSE REPAIR KITS

Each Hose Repair Kit Contains 12 Parts to Repair Any Damaged or Cut Twin Hose. Locking Crimping Tool Included with Kit 86139. Each Compartment Clearly Marked for Easy Identification.

Make hose repairs
fast and simple!



86139

Included With Kit

(1) 10-1/2" x 6-1/2" Plastic Box with 13 Compartments

- 86124** (4) Acetylene Hose Nuts
- 86125** (4) Oxygen Hose Nuts
- 86126** (8) 3/16" Hose Ferrules
- 86127** (2) 3/16" Hose Brace
- 86128** (4) 3/16" Oxy-Acetylene Hose Nipples
- 86129** (2) Oxygen Hose Couplers
- 86130** (2) Acetylene Hose Couplers
- 86131** (4) 3/16" Oxy-Acetylene Hose Splicers
- 86135** (8) 1/4" Oxy-Acetylene Hose Ferrules
- 86136** (2) 1/4" Oxy-Acetylene Hose Braces
- 86137** (3) 1/4" Oxy-Acetylene Hose Nipples
- 86138** (3) 1/4" Oxy-Acetylene Hose Splicers
- 86116** (1) Locking Grip Crimping Tool

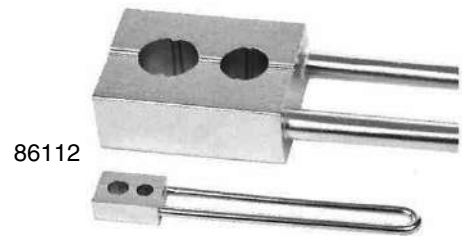

86112

86112 HAMMER TYPE CRIMPING TOOL

An inexpensive way to crimp twin welding hose ferrules. Crimps both 3/16" and 1/4" hose ferrules.



86116

86116 LOCKING JAW CRIMPING TOOL

Safely crimps twin welding hose ferrules on 3/16" and 1/4" hose.



ADAPTERS (OXYGEN AND ACETYLENE CYLINDERS)

For connecting oxygen, acetylene, argon etc. regulators to their respective tanks. When the connections between the regulator and tank do not match, one of these adapters may complete the connection.

87805 CGA 520 TO CGA 510

For all B Tanks (SSA-74B). "B" Tank Cylinder to POL Acetylene Regulator

87805



86189 Regulator To Tank Adapter

CGA 510 to CGA 410

86189



86190 Propane Cylinder To Hose Adapter

CGA 510 by 9/16 - 18LH

86190



OXY-ACETYLENE TORCH KITS & ACCESSORIES

PRESSURE GAUGES AND GAS CYLINDERS



87494



87495



87496



87497



87727



87728



87729



87730

PRESSURE GAUGES

All pressure gauge threads are common to Forney, Victor, Harris, Smith & Marquette regulators. Brass case gauges for long life.

87494 LOW PRESSURE GAUGE ACETYLENE

0-30 PSI. 2-1/2" 1/4" NPT

87495 HIGH PRESSURE GAUGE ACETYLENE

0-400 PSI. 2-1/2" 1/4" NPT

87496 LOW PRESSURE GAUGE OXYGEN

0-200 PSI. 2-1/2" 1/4" NPT

87497 HIGH PRESSURE GAUGE OXYGEN

0-4000 PSI. 2-1/2" 1/4" NPT

87727 HIGH PRESSURE GAUGE OXYGEN

0-4000 PSI. 2" 1/4" NPT

87728 HIGH PRESSURE GAUGE ACETYLENE

0-400 PSI. 2" 1/4" NPT

87729 LOW PRESSURE GAUGE OXYGEN

0-200 PSI. 2" 1/4" NPT

87730 LOW PRESSURE GAUGE ACETYLENE

0-30 PSI. 2" 1/4" NPT

86224 OXYGEN TANK (EMPTY)

20 cu. ft. cylinder. "R" size. Recommended for portable or light demand. For use with Forney 1753 Tote-A-Torch. (Or similar Torch Kits)

86228 ACETYLENE TANK (EMPTY)

10 cu. ft. cylinder. "MC" size. Recommended for portable or light demand. For use with Forney 1753 Tote-A-Torch. (Or similar Torch Kits)

85362 ARGON-CO₂ TANK (EMPTY)

20 cu. ft. cylinder. For use with most Mig Welders. Can be used with #85363 regulator.

86210 VALVE WRENCH

For small "B" and "MC" cylinders (No Picture)



85362

86224

86228

All gas cylinders are shipped empty as per DOT regulations.

OXY-ACETYLENE TORCH KITS & ACCESSORIES

WELDING NOZZLES & CUTTING TIPS FOR FORNEY & VICTOR MEDIUM DUTY 1680,1705,1753 TORCH KITS

VICTOR STYLE OXY-ACETYLENE WELDING NOZZLES

Use with 87795 Mixer Assembly. See below

87822.....#0	87825.....#3
87823.....#1	87826.....#4
87824.....#2	



87822

VICTOR STYLE OXY-ACETYLENE CUTTING TIPS

Style 3-101

60445.....#000	60448.....#1
60446.....#00	60449.....#2
60447.....#0	60450.....#3
	60451.....#4



60447

VICTOR STYLE PROPANE CUTTING TIPS (2-PIECE)

Style 3-GPN

60482.....#0	60485.....#3
60483.....#1	87936.....#4
60484.....#2	

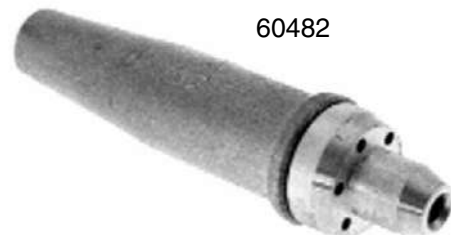

60482

MEDIUM DUTY VICTOR STYLE ROSEBUD HEATING NOZZLE

Includes Mixer Assembly.
Fits model torch 1705 & 1753.

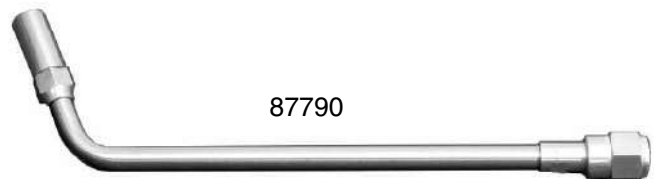

87790

M.D. VICTOR STYLE WELDING NOZZLES & CUTTING TIPS

OXY-ACETYLENE TORCH KITS & ACCESSORIES

VICTOR STYLE WELDING NOZZLES & CUTTING TIPS

CUTTING AND HEATING TIPS FOR FORNEY SERIES 01711& 01757 TORCHES

OXY-ACETYLENE CUTTING TIPS FOR Victor Style Journeyman

Style 1-101 for 1757 & 01711

60462*#0	60465*#3
60463*#1	87864*#4
60464*#2	



PROPANE CUTTING TIPS FOR Victor Style Journeyman

Style 1-GPN for journeyman & 1757 & 01711

60471*#1	60473*#3
60472*#2	87868*#4



HEAVY DUTY VICTOR STYLE ROSEBUD HEATING NOZZLE Style Victor for 1757 & 01711

87791*with Mixer Assembly



87796* - MIXER ASSEMBLY FOR H.D. VICTOR STYLE TORCH HANDLES

Use with 87102, 86177 & 87822 - 87826 welding tips.



* Indicates a skin-packed display item

OXY-ACETYLENE TORCH KITS & ACCESSORIES

1753 TOTE-A-TORCH PORTABLE VICTOR TYPE OXY-ACETYLENE OUTFIT

COMPLETE W / CYLINDERS

Lightweight Torch Kit is easy to store and can be carried from job-to-job. Ideal for auto repair, plumbing, refrigeration, metal art, general & industrial maintenance. It welds up to 1/2" & cuts up to 4". All accessories fit comfortably in a light, sturdy plastic tote.

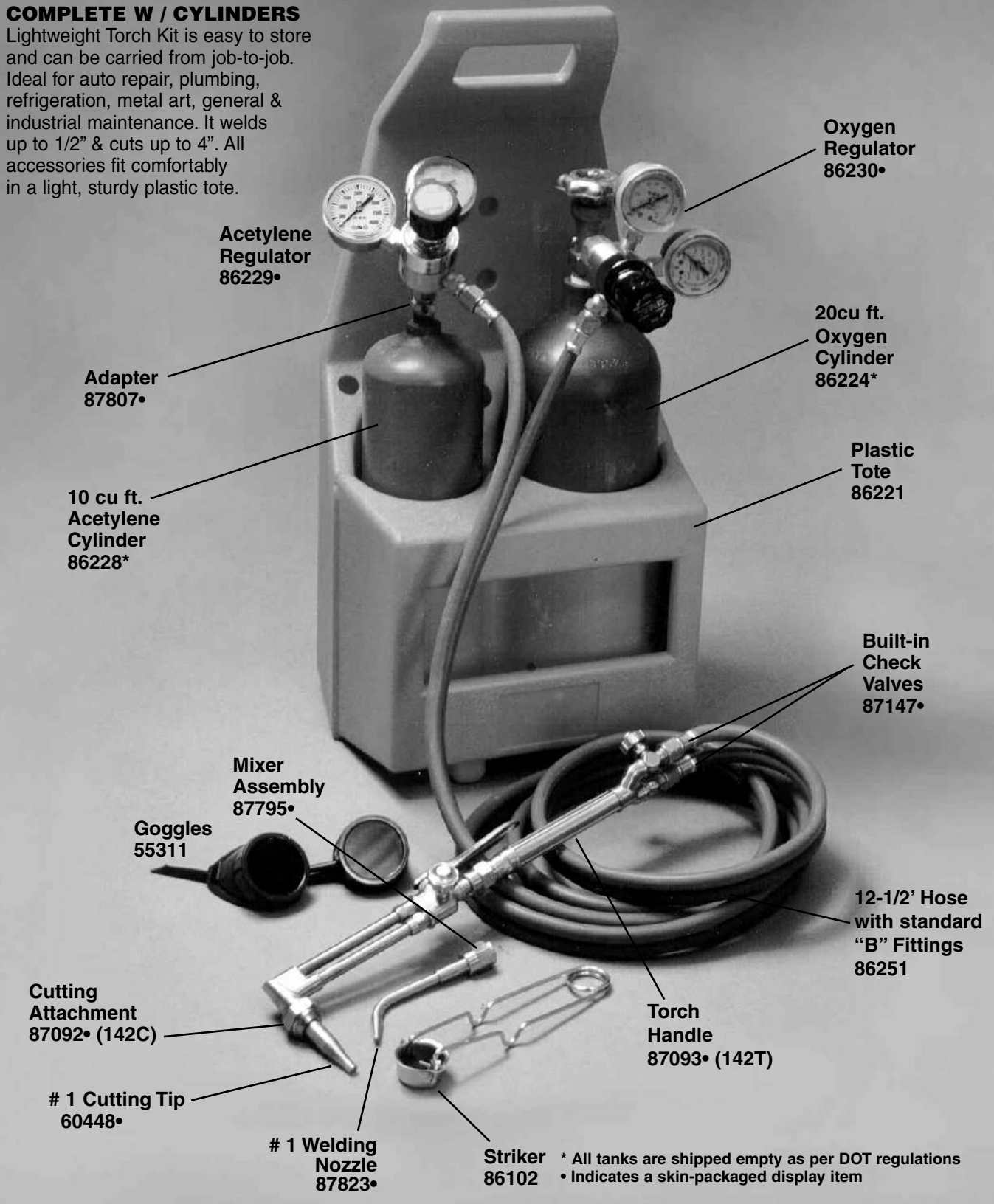

Acetylene Regulator 86229•

Oxygen Regulator 86230•

Adapter 87807•

20cu ft. Oxygen Cylinder 86224*

10 cu ft. Acetylene Cylinder 86228*

Plastic Tote 86221

Built-in Check Valves 87147•

Mixer Assembly 87795•

Goggles 55311

12-1/2' Hose with standard "B" Fittings 86251

Cutting Attachment 87092• (142C)

Torch Handle 87093• (142T)

1 Cutting Tip 60448•

1 Welding Nozzle 87823•

Striker 86102

* All tanks are shipped empty as per DOT regulations
• Indicates a skin-packaged display item

1753 TOTE-A-TORCH PORTABLE OXY-ACETYLENE TORCH KIT

OXY-ACETYLENE TORCH KITS & ACCESSORIES

1705 SHOP FLAME II TORCH KIT & REGULATORS



1705

1705 SHOP FLAME II TORCH KIT

Medium-Duty Oxy-Acetylene Unit. Precision engineered and Designed for Trouble-Free Performance. Welds up to 1/2" and Cuts up to 6". Features Built In Check Valves. Comes Complete with 20' Hose.



87090



87091

Cat. #	Description
87090•	OXYGEN REGULATOR
87091•	ACETYLENE REGULATOR
87092•	CUTTING ATTACHMENT
87093•	WELDING TORCH HANDLE
87795•	MIXER ASSEMBLY
87822•	WELDING TIP
60448•	CUTTING TIP
55311	GOGGLES
86101	HOSE (3/16" x 20')
86102	STRIKER
87147	CHECK VALVES



87092



87093

OXY-ACETYLENE TORCH KITS & ACCESSORIES



1711• FOR THE “BIG JOBS” FORNEY SHOP FLAME HEAVY-DUTY TORCH KIT

All Components Feature Quality, Sturdy Construction for the Most Demanding Heavy-Duty Welding. Welds up to 1/2”, Cuts up to 8”. Comes Complete with Hose.

Cat. #	Description
87102•	WELDING TORCH HANDLE
87104•	CUTTING ATTACHMENT
87100•	OXYGEN REGULATOR
87101•	ACETYLENE REGULATOR
87796•	MIXER ASSEMBLY
87832•	#0 WELDING TIP
60463•	#1 CUTTING TIP
86102	STRIKER 55311 GOGGLES
86101	HOSE 3/16”X20’ (not shown)



87102

87102• VICTOR WELDING TORCH
HANDLE REPLACEMENT FOR 1711



87104

87104• VICTOR CUTTING ATTACHMENT
REPLACEMENT FOR 1711



87100

87100• VICTOR OXYGEN REGULATOR

For Victor 1711 and other professional heavy duty applications. 2-1/2” dial faces.



87101

87101• VICTOR ACETYLENE REGULATOR

For Victor 1711 and other professional heavy duty applications. 2-1/2” dial faces.

• Indicates a skin-packed display item

OXY-ACETYLENE TORCH KITS & ACCESSORIES

1680 VICTOR COMPATIBLE LIGHT-MEDIUM DUTY TORCH KIT

Light to Medium Duty Oxy-Acetylene Unit Welds up to 3/16" and Cuts up to 4". Features Built In Check Valves for Safety. Ideal for Maintenance, Automotive, Fabrication, Plumbing and Do-It-Yourselfers. Provides High Performance at a Very Economical Price. Comes Complete with Hose.



Cat.#	Description
87070•	OXYGEN REGULATOR
87071•	ACETYLENE REGULATOR
87092•	CUTTING ATTACHMENT
87093•	WELDING HANDLE
87795•	MIXER ASSEMBLY
87822•	#0 WELDING NOZZLE
60448•	#1 CUTTING TIP
86251	3/16" x 12.5' HOSE (not shown)
86102	STRIKER
55311	GOGGLES

1680 TORCH KIT & ACCESSORIES

87070• OXYGEN REGULATOR (190X)
for 1680 & other light-medium duty applications on most oxygen cylinders

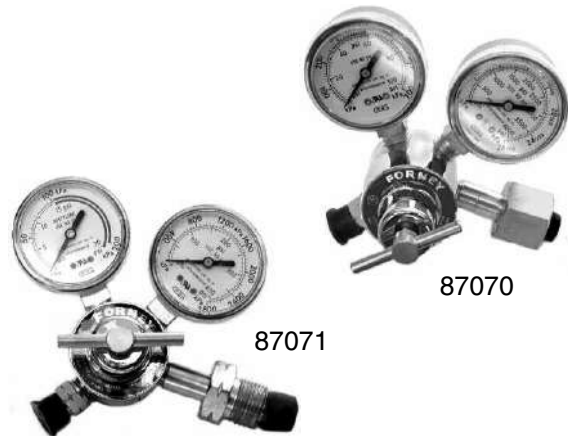

87071• ACETYLENE REGULATOR (190Y)
for 1680 & other light-medium duty applications on most acetylene cylinders.



87092• CUTTING ATTACHMENT (142T)
for 1680

87093• WELDING HANDLE (140C) for 1680



87795 MIXER
for medium duty Victor style torch handles.
Use with 87093, 87750 & 87822 - 87826 welding tips.



OXY-ACETYLENE TORCH KITS & ACCESSORIES



1687 PRO FLAME HARRIS STYLE TORCH KIT

Medium Duty Oxy-Acetylene Unit Features Built-In Check Valves for Safety & Three Tube Cutting Attachment Design. Welds up to 1/2" and Cuts up to 5". Comes with 20' Hose.

Cat. #	Description
87080•	OXYGEN REGULATOR
87081•	ACETYLENE REGULATOR
87086•*	CUTTING ATTACHMENT
87087•*	WELDING TORCH HANDLE
87084•*	MIXER ASSEMBLY
60428•	#1 CUTTING TIP
87203•	#3 WELDING TIP
86102•	STRIKER
55311•	GOGGLES
86101•	HOSE 3/16" x 20'



87086

***87086• CUTTING ATTACHMENT**
for 1687 harris style (442c)



87087

***87087• WELDING TORCH HANDLE**
for 1687 harris style(442t)



87080

87080• OXYGEN REGULATOR

for 1687 harris style (452x)

And other medium duty applications



87081

Regulators can be used on all Oxygen & Acetylene cylinders

87081• ACETYLENE REGULATOR

for 1687 harris style (452y)

And other medium duty applications



87084

87084• MIXER

For HARRIS STYLE TORCH

* Will not interchange with Harris Equipment

1687 PRO FLAME MEDIUM DUTY TORCH KIT



OXY-ACETYLENE TORCH KITS & ACCESSORIES

The Original
TIGER TORCH MANUFACTURING
95-B

Three hose lengths Available

3410	10 ft. Hose
3415	15 ft. Hose
3420	20 ft. Hose

208,000 B.T.U. at 30 lbs. P.S.I

Hose assembly and regulator sold separately.



Great for thawing frozen pipes and valves, Preheating steel and pipe for welding, Burning weeds, Heating Pots Kettles, Branding irons and any other applications requiring intense heat.

1723• ALL PURPOSE UNI-FLAME BURNER/500,000 BTU'S

- Burn Weeds, Melt Ice and Repair Asphalt and Tar on Roads
- Complete with Striker and 10' Hose
- Attaches Directly to Small 20# Propane Cylinder with POL Fitting
- Attractively Skin-Wrapped*



1720

1720• COMPACT, LIGHT-DUTY AIR ACETYLENE PLUMBER'S TORCH KIT

For Plumbing, Heating and Refrigeration Use

- Heat, Solder & Braze Pipe, Tubing & Thin Gauge Metals
- Easy to Operate
- Adjusts Fuel-Air Mixture Accurately

Cat.#	Description
88061•	#1 Brazing Heating Tip
88062•	#3 Brazing Heating Tip
88063•	#5 Brazing Heating Tip
88064•	Regulator/400 PSI
88065•	Gauge for Regulator (88064)
88066•	Air/Acetylene Hose (12-1/2"x3/16" A Fittings)
88067•	Torch Handle

*Included in Kit.



1723

OXY-ACETYLENE TORCH KITS & ACCESSORIES

WELDING NOZZLES AND CUTTING TIPS FOR FORNEY 1687 TORCH KIT & HARRIS MEDIUM DUTY EQUIPMENT

HARRIS STYLE WELDING NOZZLES-THREADED

Fit #87084 or 87720 mixer

87200.....#0	87202.....#2
87201.....#1	87203.....#3
87204.....#4	87205.....#5
87207.....#7	87220.....Mixer



HARRIS STYLE OXY-ACETYLENE CUTTING TIPS

6290 series

60427.....#0	60430.....#3
60428.....#1	60431.....#4
60429.....#2	



HARRIS STYLE PROPANE CUTTING TIPS (2-PIECE STYLE)

6290 Series

60432.....#00	60435.....#2
60433.....#0	60436.....#3
60434.....#1	



87131• MODEL J63-2 HARRIS STYLE ROSEBUD HEATING TIP

Fits #87084 or 87220 Mixer



87084• MIXER ASSEMBLY FOR 1687

(use 87220 for Genuine Harris Equipment)



87220• ROSEBUD & WELDING TIP MIXER ASSEMBLY. HARRIS E-43

(For 1687 Kit see 87084)



HARRIS STYLE TIPS AND MIXERS

OXY-ACETYLENE TORCH KITS & ACCESSORIES

VICTOR TYPE HEAVY-DUTY TORCH TIPS FOR 1711 COMMANDER, SHOP FLAME (H.D.) AND VICTOR JOURNEYMAN

VICTOR TYPE HEAVY-DUTY TORCH TIPS FOR 1711 COMMANDER, SHOP FLAME (H.D.) AND VICTOR JOURNEYMAN

Description	Victor#	Forney #
Acetylene Cutting Tip	0-1-101	60462
Acetylene Cutting Tip	1-1-101	60463
Acetylene Cutting Tip	2-1-101	60464
Acetylene Cutting Tip	3-1-101	60465
Propane Cutting Tip	1-GPN	60471
Propane Cutting Tip	2-GPN	60472
Propane Cutting Tip	3-GPN	60473
Acetylene Rosebud Tip	8-MFA	87791

VICTOR TYPE SUPER RANGE TORCH TIPS FOR FORNEY 1680 JET FLAME SHOP FLAME 1705 SHOP FLAME II AND 1753 TOTE-A-TORCH

VICTOR TYPE SUPER RANGE TORCH TIPS FOR FORNEY 1680 JET FLAME 1705 SHOP FLAME II AND 1753 TOTE-A-TORCH

Description	Victor #	Forney #
Acetylene Cutting Tip	0-3-101	60447
Acetylene Cutting Tip	1-3-101	60448
Acetylene Cutting Tip	2-3-101	60449
Acetylene Cutting Tip	3-3-101	60450
Propane Cutting Tip	0-3-GPN	60482
Propane Cutting Tip	1-3-GPN	60483
Propane Cutting Tip	2-3-GPN	60484
Propane Cutting Tip	3-3-GPN	60485
Propane Cutting Tip	4-3-GPN	87936
Acetylene Welding Nozzle	0-ET	87822
Acetylene Welding Nozzle	1-ET	87823
Acetylene Welding Nozzle	2-ET	87824
Acetylene Rosebud Tip	8-MFA-1	87790

CUTTING GUIDE & OETIKER CLAMPS

CUTTING GUIDE FOR ACETYLENE VICTOR TYPE TIPS Series 1-101, 3-101 & 5-101

VICTOR STYLE ACETYLENE CUTTING TIP CHART Series 1-101, 3-101 and 5-101

Metal Thickness	Tip Size	Cutting Oxygen Pressure (PSI)	Pre-Heat Oxygen (PSI)	Acetylene Pressure (PSI)	Speed I.P.M.	Kerf Width
1/4	00	20/25	3/5	3/5	20/28	.05
3/8	0	25/30	3/5	3/5	18/26	.06
1/2	0	30/35	3/6	3/5	16/22	.06
3/4	1	30/35	4/7	3/5	15/20	.07
1	2	35/40	4/8	3/6	13/18	.09
2	3	40/45	5/10	4/8	10/12	.11

VICTOR STYLE CUTTING TIP CHART FOR PROPANE, NATURAL GAS, LPG (Series GPN)

Metal Thickness	Tip Size	Cutting Oxygen Pressure (PSI)	Pre-Heat Fuel gas Pressure (PSI)	Speed I.P.M.	Kerf Width
1/4	00	20/25	3/5	21/25	.05
3/8	0	25/30	3/5	20/24	.06
1/2	0	30/35	3/5	18/22	.06
3/4	1	30/35	3/6	15/20	.08
1	2	35/40	3/6	14/18	.09
2	3	40/45	4/8	10/14	.10
2-1/2	3	45/50	5/9	9/12	.10

OETIKER CLAMPS

OETIKER 2 EAR CLAMPS - medium pressure for use on rubber hose, plastic tubing, co-axial and other electrical cable, rope, etc. Use on air, fluid, gas and steam hoses. Suitable for low pressure hydraulics.

INSTALL CORRECTLY

A clamp that is too tight can collapse or deform the material causing leakage. When the clamp ears can be closed all the way the clamp is normally too big and the next smaller size should be used. Close first ear, then the second. When second ear is closed, first one opens slightly and may be squeezed again. Each ear should not be squeezed more than twice.

Cat. #	SIZE	Cat. #	SIZE
86150	1/4"	86156	5/8"
86151	5/16"	86157	3/4"
86153	7/16"	86158	7/8"
86154	1/2"	86159	15/16"
86155	9/16"	86160	1"

86161 PLIERS FOR OETIKER CLAMPS

Provides easy application and removal of Oetiker clamps.

OXY-ACETYLENE TORCH KITS & ACCESSORIES

PUROX STYLE OXY-ACETYLENE CUTTING TIPS MEDIUM STYLE

General purpose, medium preheat cutting tips sufficient for beveling. Six preheat holes. Fit models CW 200 and CW 202. Style 4202. Cutting depth indicated.

60515.....# 3	60517.....# 7
60516.....# 5	



AIRCO STYLE* OXY-ACETYLENE CUTTING TIPS

General purpose. Four preheat holes for medium preheating, machine cutting. Style 144. Also fit units using styles 164 and 138. Fit Airco Models 3790-4690-4700-5700-1100-3000-9000 and 9500

60506.....# 1	60508# 3
60507.....# 2	60509PROPANE # 1



SMITH STYLE OXY-ACETYLENE MC 12

FOR MODELS MC 505 & 509, AC 305 AND 309. CUTTING DEPTH INDICATED

60406.....# 0 (MC 12-0)
60407# 1 (MC 12-1)
60408.....# 2 (MC 12-2)
60409.....# 3 (MC 12-3)



SMITH STYLE OXY-PROPANE CUTTING TIPS

STYLE MC 40 FOR MEDIUM-DUTY UNITS

60413.....# 2 (MC 40-2)



SMITH STYLE OXY-ACETYLENE CUTTING TIPS FOR HEAVY-DUTY UNITS.

SC SERIES TIPS NOT FOR MC SERIES TORCHES

60402.....# 1 (SC 12-1)
60403.....# 2 (SC 12-2)
60404.....# 3 (SC 12-3)



PUROX, REGO, AIRCO & SMITH STYLE CUTTING TIPS

METAL WORKING AND SHOP TOOLS

70500 CHIPPING HAMMER WITH BRUSH 70501

The king of all chipping hammers. Tempered chisel to resist dulling during heavy duty usage. Impact resistant handle. Steel wire brush for cleaning. Brush is removable, reversible and replaceable. Loop in handle for belt hook. Black 12" long.



70501 STEEL WIRE BRUSH

Replacement brush for Forney 70500 Chipping Hammer. Sturdy, high quality steel wire brushes set in hardwood with hang hole.



70600 CHIPPING HAMMER STRAIGHT HEAD

High carbon steel. Tempered flat chisel on one end. Point on the other end. Durable. All-purpose. Shock proof handle with loop for belt hook. Black. 10-1/2" long.

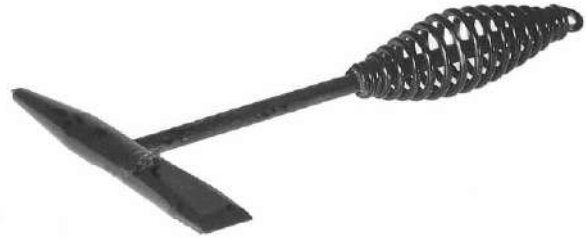

70601 CHIPPING HAMMER CROSS-PEEN STYLE

High carbon steel. Tempered flat chisel on one end. Point on the other end. Durable. All-purpose. Has shock proof handle with loop for belt hook. Black. 10-1/2" long.



70610 CHIPPING HAMMER STRAIGHT HEAD WOOD HANDLE

High carbon steel. Tempered flat chisel on one end. Point on the other end. Durable. All-purpose. Sturdy. Hardwood handle for comfort. 10-1/2" long.



METAL WORKING AND SHOP TOOLS

WOOD HANDLE WIRE SCRATCH BRUSHES FOR PAINT & RUST REMOVAL

Heavy-duty wire brushes. Strong, durable, solidly imbedded Carbon Steel, Brass and Stainless Steel bristles. Long or shoe handles with pre-drilled hang holes. Carbon Steel brushes especially good for aggressive cleaning, removing rust and paint from most surfaces. Stainless Steel brushes ideal for cook-out grills, dairy operations, restaurants and surfaces exposed to high humidity. Brass brushes for general purpose cleaning and excellent for cleaning Stainless Steel & Aluminum



70516



70518 Brass
70504 Carbon Steel
70521 Stainless Steel



70517



70519 Brass
70505 Carbon steel
70520 Stainless steel

Cat. #	Description	Wire Rows
70516	13½" Long Handle Carbon Steel w Metal Scraper	3 x 19
70504	13½" Long Handle Carbon Steel	3 x 19
70518	13½" Long Handle Brass	3 x 19
70521	13½" Long Handle Stainless	3 x 19
70517	10¼" Shoe Handle Carbon Steel W Metal Scraper	4 x 16
70505	10¼" Shoe Handle Carbon Steel W Metal Scraper	4 x 16
70519	10¼" Shoe Handle Brass	4 x 16
70520	10¼" Shoe Handle Stainless	4 x 16

V-GROOVE WIRE BRUSHES LONG HANDLE (3x14 ROWS)

70522 CARBON STEEL 13-1/2"

Great for cleaning tight, hard-to-reach-areas: welds, concrete, driveway joints, auto body seams, removing paint in corners, etc. Hang hole in handle.

70523 STAINLESS STEEL 13-1/2"

Great for cleaning tight, hard-to-reach areas in dairy operations, restaurants, boats & areas where humidity is a problem. Ideal for cleaning most aluminum. Hang hole in handle.

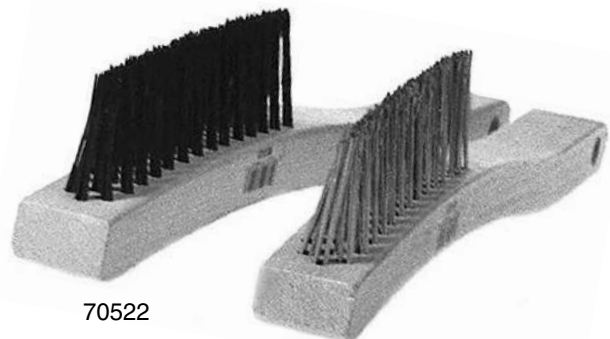

70522

70523

WIRE BRUSHES

METAL WORKING AND SHOP TOOLS

SMALL SIZE KNUCKLE SAVER STYLE BRUSHES

70488

STAINLESS STEEL WIRE BRUSH

Abrasive cleaning action. Will not rust. Plastic Handle. Hang hole in plastic handle. 7-1/4" long 3 x 7 rows.



70489 BRASS WIRE BRUSH

Abrasive cleaning action on non-ferrous materials where scratches are undesirable. Hang hole in plastic handle. 7-1/4" long 3 x 7 rows.



70490 BRASS WIRE BRUSH

Aggressive cleaning action. Will not rust. Hang hole in wooden handle. 7-1/4" long 3 x 7 rows.



70506

STAINLESS STEEL WIRE BRUSH COMPACT

General purpose cleaning, especially on aluminum. Hang hole in wooden handle. 7-3/4" long 3 x 7 rows.



MEDIUM SIZE KNUCKLE SAVER STYLE BRUSHES

70491 BRASS WIRE BRUSH

Won't scratch stainless or polished steel. Excellent for finish or delicate work. Angle-head design eliminates cut or bruised knuckles. Hang hole in wooden handle. 8-3/4" long- 2 x 9 rows.



70503 STAINLESS STEEL WIRE BRUSH

Excellent for general cleaning. Angle-head design eliminates cut and bruised knuckles. Hang hole in wooden handle. 8-3/4" long - 2 x 9 rows.



METAL WORKING AND SHOP TOOLS

NYLON TUBE BRUSH WITH WIRE HANDLE

70469 8 1/2"L x 3/4"D x 3" Brush Length

70485 8 1/2"L x 1/2"D x 3" Brush Length

Firm bristle, stiff stem brush ideal for cleaning bottles, carburetors, brake cylinders, radiator hoses, engine blocks, blocked hoses and drains, etc.

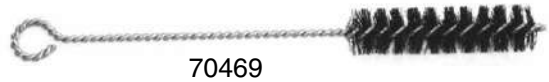

70469



70485

WIRE FITTING BRUSH WITH WIRE HANDLE

70470 6"L x 1/2"D

70484 6"L x 3/4"D

For cleaning copper fittings prior to soldering. Great for removing corrosion from battery terminals, tubing or black pipe.



70470



70484

PLASTIC HANDLED WIRE FITTING BRUSHES

70471 4-3/4"L x 1/2"D

70472 4-3/4"L x 3/4"D

For cleaning plumbing joints prior to soldering. Great for removing corrosion from battery terminals, tubing & black pipe.

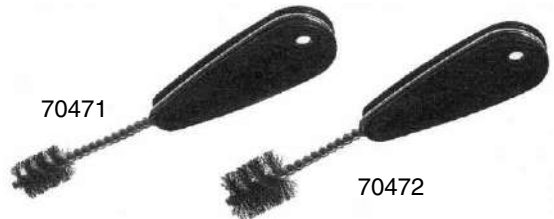

70471

70472

STAINLESS STEEL POWER TUBE BRUSHES

70473 4"L x 1/2"D

70474 4"L x 3/4"D

Insert brushes in power drill for swift & easy cleaning of plumbing joints prior to soldering. Skin-packed as a display item.

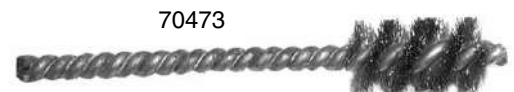

70473



70474

OUTSIDE TUBE CLEANING BRUSHES

70475 1/2" D

70476 3/4" D

Ideal for cleaning corrosion from terminals and similar cylindrical shapes.

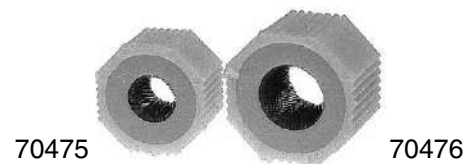

70475

70476

STAINLESS STEEL & BRASS SCRATCH BRUSHES

METAL WORKING AND SHOP TOOLS



70483 WIRE BRUSH

Solvent resistant, aggressive bristles. Wide range of cleansing applications. 5-5/16" long x 1-1/2" wide.



70507 PARTS CLEANING BRUSH ECONOMY-MEDIUM DUTY

Durable brush made entirely of polypropylene. Resistant to most auto parts cleaning solutions. One piece, unitized brush vulcanized in rubber. Size 10 brush. Overall length: 10-1/2".



70508 PARTS CLEANING BRUSH DELUXE-HEAVY DUTY

Durable brush made entirely of polypropylene. Resistant to most auto parts cleaning solutions. One piece, unitized brush vulcanized in rubber construction. Metal ferrule for more support and durability. Plus a slightly heavier fill. Size 10 brush. Overall length: 10-1/2".



70509 WIRE PARTS CLEANING BRUSH

Premium brush provides more aggressive action than nylon. Good for removing gasket material or baked on varnish. Overall length: 9"



70510 BATTERY CABLE TERMINAL BRUSH

Handy for cleaning insides of cable ends and battery posts.

UTILITY BRUSH DISPLAY

FORNEY UTILITY WIRE BRUSH DISPLAY

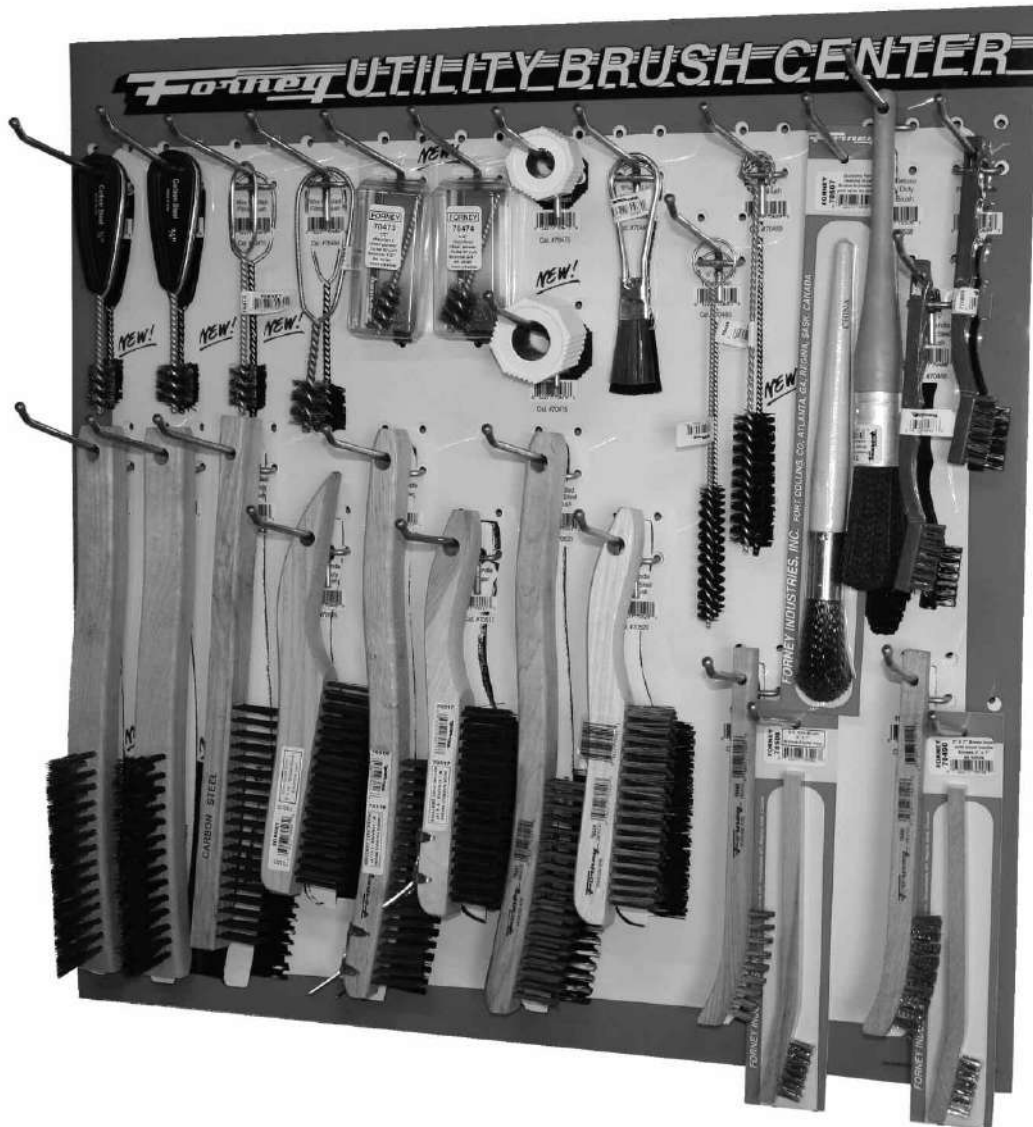

70479 FORNEY UTILITY WIRE BRUSH DISPLAY

Display includes 2 each of all brushes shown above.

Display includes 2 ea. – 70469, 70470, 70471, 70472, 70473, 70474, 70475, 70476, 70483, 70484, 70485, 70488, 70489, 70490, 70491, 70503, 70504, 70505, 70506, 70507, 70508, 70516, 70517, 70520, 70521, 70522, 70523

70480 FORNEY UTILITY WIRE BRUSH DISPLAY

Display includes 4 each of all brushes shown above.

Display includes 4 ea. – 70469, 70470, 70471, 70472, 70473, 70474, 70475, 70476, 70483, 70484, 70485, 70488, 70489, 70490, 70491, 70503, 70504, 70505, 70506, 70507, 70508, 70516, 70517, 70520, 70521, 70522, 70523

METAL WORKING AND SHOP TOOLS



70221 DELUXE MAGNETIC LEVEL

An all position—vertical, horizontal and diagonal—magnetic level. Strong lifetime magnet frees hands for work. Designed for mechanics, engineers, plumbers, sheet metal workers, electricians, carpenters, masons, hobbyists and homemakers. Patented. 90 day warranty. 9" x 1-1/4" x 1/2". **(Blister Packed)**



70709/70710 4-WAY PICK REPAIR KIT

Handy repair kit includes four tempered steel picks: retriever pick, "O" ring remover, 90° pick and straight pick/scraper. Convenient. Durable. Built with quality. Useful for professional or handyman.

Available in 4" (70709) or 6" (70710) lengths - 4/pkg



70714• PREMIUM SCRIBE

Useful marking tool features a handy pocket clip, knurled aluminum handle and tungsten carbide tip. Also cuts glass.



PAINT MARKER (Yellow only)

70811 SKIN-PACKED 2/CARD

Unique because it is really **Paint!** Doesn't fade. Weatherproof. Marks permanently on wet, dry, smooth or extremely rough surfaces. Even on oily, icy, slick surfaces such as lumber, plastics, ceramics, rubber, glass and **all** metals. Contains no lead or zinc compounds.

METAL WORKING AND SHOP TOOLS



70718 COMBO SCRIBE-MAGNET

All the features of the 70714 plus a powerful Alnico magnet for metal retrieval.



70722 THIN FLEX MAGNET

Won't lose its shape going around corners. Rigid, yet can be bent to any shape. 20" overall length.



70802 SOAPSTONE PENCIL FLAT METAL HOLDER

With pocket clip. Refills: 80803, 80805 & 60306

80805.....	1 Gross Box (144)
80803.....	Single
60306.....	3 per Pkg.



70807 SOAPSTONE PENCIL ROUND ALUMINUM HOLDER

With pocket clip. Refills: 80801, 80800 & 60305

80800.....	1 Gross Box (144)
80801.....	Single
60305.....	3 per Pkg.

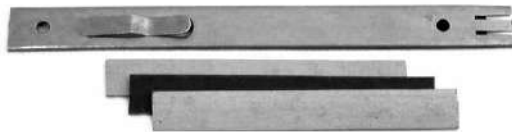

70795 THIN LINE MARKING PENCIL

Visible under heat. More break-resistant than soapstone. Makes thin lines without resharpening. Comes with 3 refills: 1 red and 2 silver.



70796 SILVER THIN LINE REFILL

Excellent for marking metals & all layout measurement work.



70797 RED THIN LINE REFILL

Excellent for light, bright or polished metals, wood and all your measurement work.

SOAPSTONE PENCILS

METAL WORKING AND SHOP TOOLS



70201 LOCKING PLIER STYLE C-CLAMP

Extra clamping capacity for large objects. 10-1/2" long. 3-3/4" maximum opening. 3" depth.

70202 LOCKING PLIER WITH SWIVEL PADS



70301 LOCKING PLIER STYLE WELDING CLAMP

Designed to grip a few inches from end of metal. Allows weld to start or finish at end of joint. Plated steel construction. 2" maximum jaw opening. 8-3/8" long. 2-1/2"-3" depth.



70235 LOCKING PLIER STYLE CHAIN CLAMP

Designed to grip anything the chain can be wrapped around. Releases with the flick of a finger. Ideal for pipes and awkward shaped items.



MALLEABLE IRON C-CLAMPS 3" & 4"

High quality C-clamp for light industrial use. Malleable cast metal frame. Copper plated screw, Swivel pad and Sliding T- handle.

70226 / 70227

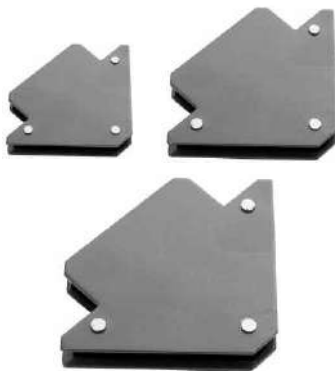

MULTI-PURPOSE MAGNETS

70716 SMALL

70717 MEDIUM

70715 LARGE

These strong magnets stick to any iron object. Magnets have 45, 90 & 135 degree angles. Excellent "3rd Hand" for welding, soldering, assembly, pipe installation, marking, floating and separating thin metal stacks. Hole in 70717 is for crane mounted lifting of small items.

(CAUTION: MAGNETS ARE NOT FOR OVERHEAD USE.)

METAL WORKING AND SHOP TOOLS

HACKSAWS

ULTRA HIGH PERFORMANCE FRAME AT A COMPETITIVE PRICE
 CAT# 21277 DE33K #33 HACKSAW FRAME/KNOB

STORE UP TO 10 EXTRA BLADES IN TOP OF FRAME.

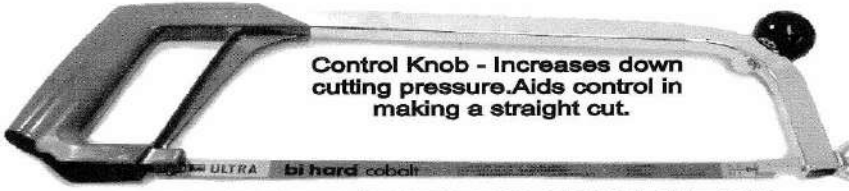

Control Knob - Increases down cutting pressure. Aids control in making a straight cut.

BLADE CAN BE ROTATED FOR FLUSH CUTTING

21277 HACKSAW BLADES

Ultra high performance frame. *Variable tooth blades bring teeth into the work at constantly changing angles for faster, smoother and quieter cutting. Stores up to 10 extra blades in the top of the frame. Control Knob increases down cutting pressure. Aids control in making a straight cut.

Cat. #	Size	Teeth/In.
72005	12" Bi-Metal	18
72006	12" Bi-Metal	24
72007	12" Bi-Metal	32

POWER HACKSAW BLADES

Redstripe Molybdenum High Speed Steel For general purpose cut-off jobs in powered machines. Solid high-speed steel, hardened from top edge to cutting edge for maximum hardness and rigidity. Long wear life and top performance in sawing a wide range of material including stainless and tough to cut alloy steels.

8224012" x 5/8" x 14 Teeth	82243 12" x 1" x 14 Teeth
82241 12" x 5/8" x 18 Teeth	82245 14" x 1" x 14 Teeth

1/4" HEX SHANK POWER DRIVEN SCREWDRIVER BITS AND NUTSETTERS

Premium Hardened Steel. Made to Exacting Specifications.



70730

Square Recess Insert Bits 1" Long

CAT #	Size
70730	Insert # 1
70731	Insert # 2



70755

70755 # 2 Phillips Drywall Bit 1" Long

Square Recess Power Bits 2" Long



70735

CAT #	Size
70735	Power Insert # 1
70736	Power Insert # 2
80760	Power Insert # 3

SCREW DRIVER BITS AND NUT SETTERS

POWER BITS AND BIT HOLDERS

CAT #	Phillips Power Bits 2" Long
70762	Insert # 1
70763	Insert # 2
80771	Insert # 3



CAT #	Phillips Insert Bits 1" Long
70756	Insert # 1
70757	Insert # 2
70758	Insert # 3



CAT #	Flat Insert Bits 1" Long
80766	3/32" x 1" Insert # 4
80767	1/4" x 1" Insert # 6
80768	9/32" x 1" Insert # 8
70778	Magnetic Socket 1/4"
70779	Magnetic Socket 1/16"



CAT #	Magnetic Nut Setters
70770	1/4" Nut Setter 1-3/4" Long
70771	5/16" Nut Setter 1-3/4" Long
80753	3/8" Nut Setter 1-3/4" Long
80754	7/16" Nut Setter 1-3/4" Long
70776	1/4" Nut Setter 2-9/16" Long
70777	5/16" Nut Setter 2-9/16" Long



70773 Bit Holder 1/4" x 3"



80762 1/4" x 2" Extension



70738	T10 x 1" Torx Insert Bit
70739	T15 x 1" Torx Insert Bit
70740	T20 x 1" Torx Insert Bit
70741	T25 x 1" Torx Insert Bit
70742	T30 x 1" Torx Insert Bit
70743	T40 x 1" Torx Insert Bit

Torx Insert Bits



FILES AND ACCESSORIES

VALORBE CHAIN SAW FILES

These are heat treated for maximum performance and give perfect service for all filing needs. Manufactured in Switzerland. They are available in a variety of sizes, styles and shapes for all of your filing needs.

2 Files (Skin-Pack)	2 Files & Handle (Skin-Pack)	Dimensions
70365	70366	Round File 8" 5/32"
70367	70368	Round File 8" 11/64"
70369	70370	Round File 8" 3/16"
70371	70372	Round File 8" 13/64"
70373	70374	Round File 8" 7/32"



70365 - 70374



70405

703756" Flat Chain Saw File
703768" Flat Chain Saw File



70375

FORNEY MACHINIST'S FILES

70377 70378	1 Side Bastard & 1 Side Smooth	Farmer File 8" Farmer File 10"
70379 70380 70381		Flat Bastard File 8" Flat Bastard File 10" Flat Bastard File 12"
70384 70385 70386		Half Round Bastard File 8" Half Round Bastard File 10" Half Round Bastard File 12"
70382 70383		Flat Smooth File 8" Flat Smooth File 10"
70387 70388		Round Bastard File 8" Round Bastard File 10"
70389		Round Smooth File 8"
70390 70391		Square Bastard File 10" Triangular Tapered Saw File 6"
70392 70393		Half Round Bastard Rasp 10" Half Round Bastard Rasp 12"
70394		Contact Point File (2 pack)

70405 WOODEN FILE HANDLE



70395 PLASTIC CHAIN SAW HANDLE



CHAIN SAW FILE HANDLE

Plastic file handle, with built in angle guide & suspension hole.

70396	Handle for 6" and 8"
70397	Handle for 8" and 10"
70398	Handle for 12"



70396



70397



70398

CHAIN SAW FILES AND MACHINIST'S FILES ALSO AVAILABLE IN BULK QUANTITIES (PER DOZEN - 12/BOX)



HEAD OFFICE: Regina, Saskatchewan • Telephone: 1-800-667-8161 Fax: 1-800-404-3551
EASTERN WAREHOUSE: Hawkesbury Ontario • Telephone: 1-888-811-0889 Fax: 1-888-811-1120

FILES AND ACCESSORIES

70360 - ENGINEER'S OPENING FILE INVENTORY

Contains one each of the following items.

70365	70376	70386	70396
70366	70377	70387	70397
70367	70378	70388	70398
70368	70379	70389	70399
70369	70380	70390	70400
70370	70381	70391	70401
70371	70382	70392	70402
70372	70383	70393	70403
70373	70384	70394 (2)	70404
70374	70385	70395	70405
70375			
42 Items			



70361

70361 - CHAIN SAW FILE OPENING INVENTORY

Contains one each of the following items.

70365	70366	70367	70368
70369	70370	70371	70372
70373	70374	70375	70376
70395			70405
14 Items			

70362 - MACHINIST'S FILE OPENING INVENTORY

Contains one each of the following items.

70377	70381	70385	70389	70394	70400
70378	70382	70386	70390	70395	70401
70379	70383	70387	70391	70396	70402
70380	70384	70388	70392	70397	70403
			70393	70398	70404
				70399	
28 Items					

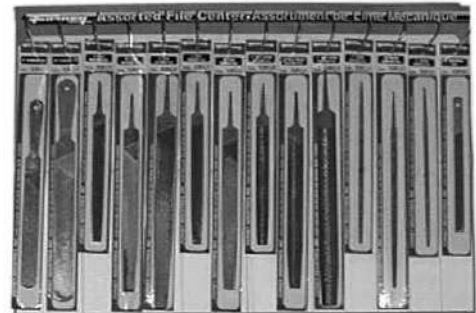

70362

70399	Mill Bastard File - 8"
70400	Mill Bastard File - 10"
70401	Mill Bastard File - 6"
70402	Extra Slim Taper Saw File - 6"
70403	Half Round Rasp - 8"
70404	Universal File - 6"

UTILITY HARDWARE CENTRE

WIRE ROPE CLIPS, THIMBLES, SHUTS, REPAIR & QUICK LINKS



WARNING: Observe all Maximum Working Load Limits listed on this notice for the specific products being used. Never exceed these limits. Overhead lifting or support of human weight requires special chain and accessories not available from Forney Industries. Inspect chain and accessories frequently and replace worn or stressed components with new product.

Wire Rope Clips, Links & Shuts allow Farmers, Garages, Service Stations, Shops & (Do-It-Yourselfers) to repair broken chains instead of replacing them. Steel Wire Rope Clips come Galvanized or Plated. Steel Quick Links, Repair Links, Cold Shuts & Thimbles also are Galvanized. **This prevents rust.**

UTILITY HARDWARE CENTRE LOZIER DISPLAY 61000—INCLUDES EIGHT 12"X24" POG'S WITH FULL DESCRIPTIONS, CAT #'S & BAR CODES: 61001 SMALL HOOK CENTRE, 61002 LARGE HOOK CENTRE, 61003 LINKING CENTRE, 61004 CLEVIS LINKS, SHACKLES & SWIVELS CENTRE, 61005 U-BOLTS CENTRE, 61006 EYE BOLTS, LAG EYES, & SCREW HOOKS CENTRE, 61007 SNAP HOOKS CENTRE, 61008 TURNBUCKLE CENTRE. THE FORNEY SPINNER RACK DISPLAY INCLUDES OPENING INVENTORY 61000 & SPINNER RACK 10279.

Linking Centre— 61003: includes POG 10602

WIRE ROPE CLIPS (Galvanized)		DIMENSIONS							
CAT. #	Size	A	B	C	D	E	G	H	#
61010	1/8"	7/32"	23/32"	7/16"	15/32"	13/32"	13/16"	15/16"	
61011	3/16	1/4	31/32	9/16	19/32	1/2	15/16	1-5/32	
61012	1/4	5/16	1-1/32	1/2	3/4	21/32	1-3/16	1-7/16	
61013	5/16	3/8	1-3/8	3/4	7/8	23/32	1-5/16	1-11/16	
61014	3/8	7/16	1-1/2	3/4	1	29/32	1-5/8	1-15/16	
61015	7/16	1/2	1-7/8	1	1-3/16	1-1/32	1-13/16	2-9/32	
61016	1/2	1/2	1-7/8	1	1-3/16	1-1/8	2-29/32	2-9/32	

WIRE ROPE CLIPS		DIMENSIONS							
CAT. #	Size	A	B	C	D	E	G	H	#
61020	1/8"	7/8"	7/16"	9/16"	1/4"	15/32"	7/16"	3/4"	
61021	3/16	1-1/16	1/2	19/32	1/4	18/32	21/32	15/16	
61022	1/4	1-1/4	19/32	23/32	5/16	21/32	3/4	1-1/4	
61023	5/16	1-3/8	5/8	3/4	5/16	23/32	7/8	1-5/16	
61024	3/8	1-19/32	7/8	7/8	3/8	25/32	1-1/16	1-5/8	
61025	1/2	1-29/32	7/8	1	15/32	1-1/16	1-3/8	2-1/8	

WIRE ROPE THIMBLE		DIMENSIONS						
CAT. #	Rope Dia.	A	B	C	D	E	F	
61030	1/8"	1-15/16"	1-1/16"	1-5/16"	11/16"	5/32"	5/8"	
61031	3/16	1-15/16	1-1/16	1-5/16	11/16	7/32	5/8	
61032	1/4	1-15/16	1-1/16	1-5/16	11/16	9/32	5/8	
61033	5/16	2-1/8	1-1/4	1-1/2	13/16	3/8	3/4	
61034	3/8	2-3/8	1-15/32	1-5/8	15/16	7/16	7/8	
61035	1/2	2-3/4	1-3/4	1-7/8	1-1/8	9/16	1 1/16	

COLD SHUT		DIMENSIONS			
CAT. #	Rope Dia.	Inside width	Inside lgth	Wt lbs	
61090	3/16"	11/32"	15/16"	.03	
61091	1/4	3/8	1-3/16	.06	
61092	5/16	7/16	1-3/8	.1	
61093	3/8	5/8	1-1/2	.18	
61094	7/16	11/16	1-9/16	.26	
61095	1/2	3/4	1-7/8	.38	

REPAIR LINKS		DIMENSIONS			
CAT. #	Rope Dia.	D2	H1	M	
61110	3/16	3/8	15/16	1/4	
61111	1/4	13/32	1-1/8	9/32	
61112	5/16	5/8	1-7/16	3/8	
61113	3/8	21/32	1-15/32	3/8	
61114	7/16	11/16	1-15/32	3/8	

QUICK LINK		DIMENSIONS			
CAT. #	Size	B1	B2	H1	
61120	3/16"	13/32"	3/16"	1-1/8"	
61121	1/4	9/16	1/4	1-1/2	
61122	5/16	9/16	9/32	1-3/4	
61123	3/8	5/8	5/16	2-1/16	
61124	7/16	25/32	15/32	2-11/16	
61125	1/2	31/32	19/32	3-1/4	



UTILITY HARDWARE CENTRE

SLIP, GRAB AND EYE HOOKS

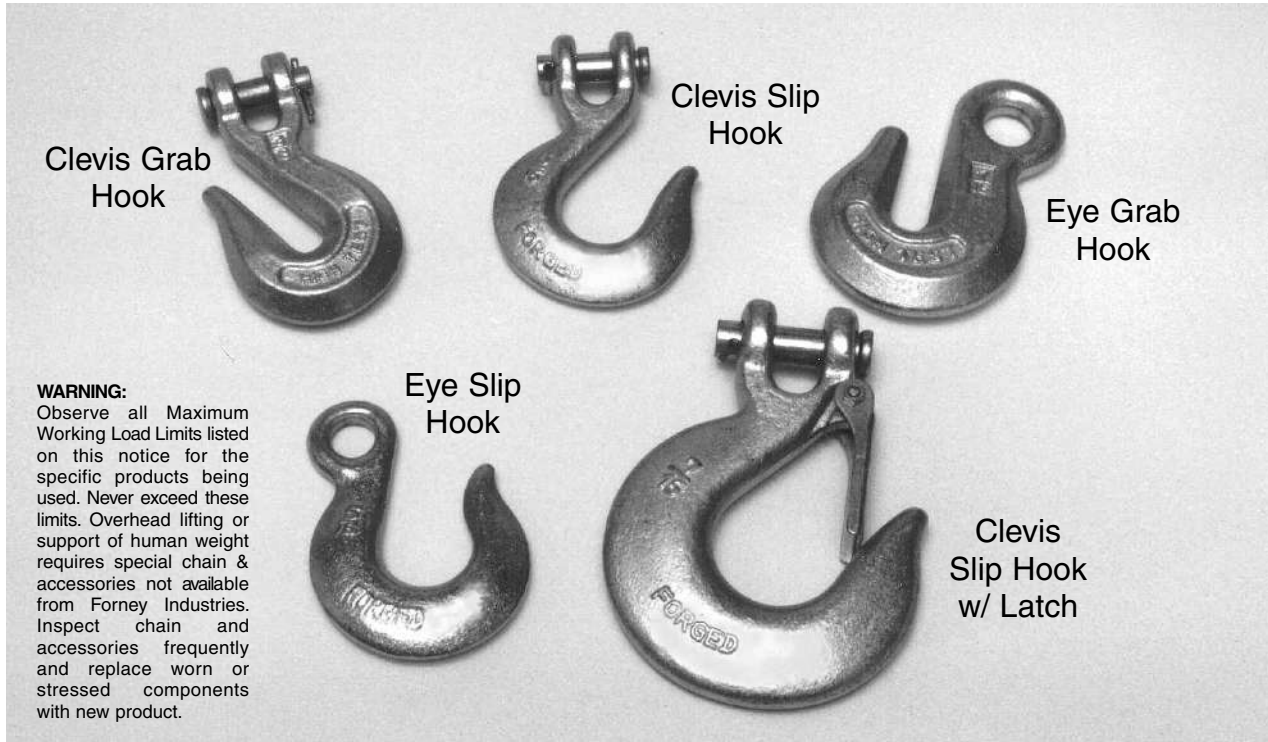

WARNING:
Observe all Maximum Working Load Limits listed on this notice for the specific products being used. Never exceed these limits. Overhead lifting or support of human weight requires special chain & accessories not available from Forney Industries. Inspect chain and accessories frequently and replace worn or stressed components with new product.

Eye, Slip & Grab Hooks Tempered from Forged carbon Steel. Working Load from 1,950 pounds to 9,200 pounds. Five Styles: Clevis Grab Hooks; Clevis Slip Hooks; Eye Grab Hooks; Eye Slip Hooks & Clevis Slip Hooks with Latches. The Hook for practically any job. Galvanized to prevent rust.

Opening Inventory—Small Hook centre 61001: includes POG 10600
Opening Inventory—Large Hook centre 61002: includes POG 10601

EYE GRAB HOOK	CAT. # Size		Max Working Load	DIMENSIONS			
	B	E		R	/ lbs		
	61060	1/4	2,600	.50	.34	1.97	.28
	61061	5/16	3,900	.56	.44	2.25	.45
	61062	3/8	5,400	.66	.50	2.56	.79
	61063	7/16	7,200	.75	.56	2.94	1.19
	61064	1/2	9,200	.88	.66	3.38	1.8

CLEVIS GRAB HOOK	CAT. # Size		Max Working Load	DIMENSIONS				
	B	E		P	R	/ lbs		
	61040	1/4	2,600	.36	.40	.38	1.97	.40
	61041	5/16	3,900	.40	.44	.44	2.26	.79
	61042	3/8	5,400	.48	.50	.47	2.63	1.0
	61043	7/16	7,200	.66	.56	.56	2.75	1.5
	61044	1/2	9,200	.75	.66	.63	3.19	2.1
	61037	1/4	Grade 70					
	61038	5/16	Grade 70					
	61039	3/8	Grade 70					

EYE SLIP HOOK	CAT. # Size		Max Working Load	DIMENSIONS			
	B	E		R	/ lbs		
	61070	1/4	1,950	.50	.94	2.56	.40
	61071	5/16	2,875	.63	1.06	2.95	.70
	61072	3/8	4,000	.72	1.31	3.36	1.0
	61073	7/16	5,000	.81	1.56	3.88	1.6
	61074	1/2	6,500	.94	1.69	4.28	2.4

CLEVIS SLIP HOOK	CAT. # Size		Max Working Load	DIMENSIONS				
	B	E		P	R	/ lbs		
	61050	1/4	1,950	.44	.94	.38	2.56	.50
	61051	5/16	2,875	.50	1.06	.44	2.87	.75
	61052	3/8	4,000	.59	1.31	.47	3.25	1.20
	61053	7/16	5,000	.66	1.56	.56	3.70	2.06
	61054	1/2	6,500	.76	1.69	.63	4.0	2.8

EYE SLIP HOOK	CAT. # Size		Max Working Load	DIMENSIONS					
	B	E		P	R	T	/ lbs		
	61080	1/4	2,750	.44	.79	.38	2.56	.79	.52
	61081	5/16	4,300	.50	.93	.44	2.87	.79	.77
	61082	3/8	5,250	.59	1.14	.47	3.25	1.02	1.23
	61083	7/16	7,000	.66	1.18	.56	3.7	1.06	2.1
	61084	1/2	9,000	.75	1.42	.63	4.0	1.38	2.85
	61085	1/4	Grade 70						
	61086	5/16	Grade 70						
	61087	3/8	Grade 70						

UTILITY HARDWARE CENTRE

WARNING: Observe all Maximum Working Load Limits listed on this notice for the specific products being used. Never exceed these limits. Overhead lifting or support of human weight requires special chain & accessories not available from Forney Industries. Inspect chain & accessories frequently & replace worn or stressed components with new product.

Twin Clevis Link



Forged Swivel



Jaw End Swivel



Screw Pin Shackle



Clevis Pin Shackle



Clevises, Shackles & Swivels are made from **Forged Heat Treated Steel**. Pins are Alloy Steel. Maximum Working Loads in Pounds. **Galvanized to prevent rust.**

Opening Inventory-61004: Clevis links, Shackles & swivels centre-includes POG 10603

JAW END SWIVEL	SIZE		Max Working Load	DIMENSIONS							
	CAT. #	SIZE		A	B	C	K	N	P	R	
	61150	1/4"	850	1-1/4"	11/16"	3/4"	15/32"	7/8"	1/4"	2-5/8"	
	61151	5/16	1,250	1-5/8	13/16	1	1/2	7/8	5/16	2-15/16	
	61152	3/8	2,250	2	15/16	1-1/4	5/8	1-1/16	3/8	3-5/8	
	61153	1/2	3,650	2-1/2	1-5/16	1-1/2	3/4	1-5/16	1/2	4-1/2	

TWIN CLEVIS	SIZE		Max Working Load	DIMENSIONS				/ lbs
	CAT. #	SIZE		A	R	D	G	
	61130	1/4-5/16	4,700	.47	1.18	.38	.43	.32
	61131	3/8	6,600	.53	1.34	.47	.48	.44
	61132	7/16-1/2	11,250	.65	1.75	.56	.63	1.0

SCREW PIN SHACKLE	SIZE		Max Working Load	DIMENSIONS				
	CAT. #	SIZE		L	WTH	WB	DP	DE
	61160	3/16"	666	7/8"	3/8"	11/16"	1/4"	9/16"
	61161	1/4	1,000	1-1/8	1/2	25/32	5/16	11/16
	61162	5/16	1,500	1-7/32	17/32	27/32	3/8	13/16
	61163	3/8	2,000	1-7/16	21/32	1-1/32	7/16	31/32
	61164	7/16	3,000	1-11/16	23/32	1-5/32	1/2	1-1/16
	61165	1/2	4,000	1-7/8	13/16	1-5/16	5/8	1-3/16

FORGED SWIVEL	SIZE		Max Working Load	DIMENSIONS				
	CAT. #	SIZE		A	B	C	D	R
	61140	1/4"	850	1-1/4"	11/16"	3/4"	1-1/16"	2-5/16"
	61141	5/16	1,250	1-5/8	13/16	1	1-1/4	3-9/16
	61142	3/8	2,250	2	15/16	1-1/4	1-1/2	4-5/16
	61143	1/2	3,600	2-1/2	1-5/16	1-1/2	2	5-7/16

CLEVIS PIN SHACKLE	SIZE		Max Working Load	DIMENSIONS				
	CAT. #	SIZE		L	WTH	WB	DP	DE
	61170	3/16	666	7/8"	3/8"	11/16"	1/4"	9/16"
	61171	1/4	1,000	1-1/8	1/2	25/32	5/16	11/16
	61172	5/16	1,500	17/32	17/32	27/32	3/8	13/16
	61173	3/8	2,000	15/32	21/32	1-1/32	7/16	31/32
	61174	7/16	3,000	23/32	23/32	1-5/32	1/2	1-1/16
	61175	1/2	4,000	13/16	13/16	1-5/16	5/8	1-3/16

SHACKLES, SWIVELS AND CLEVISES

UTILITY HARDWARE CENTRE

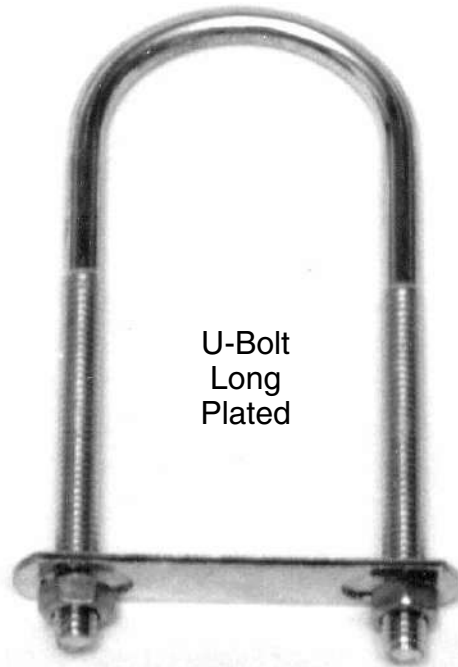
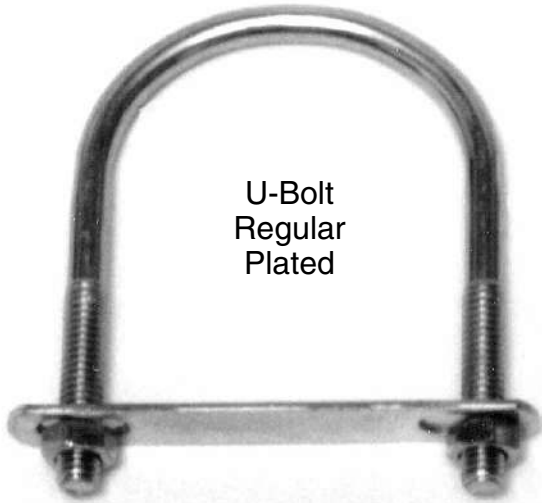

Virtually any size to satisfy the needs of any job for Do-It-Yourselfers, Contractors, Carpenters or Auto Mechanics.

Opening Inventory for U-Bolt Centre-61005: includes POG 10604

PLATED U-BOLTS

U-BOLTS PLATED REG.

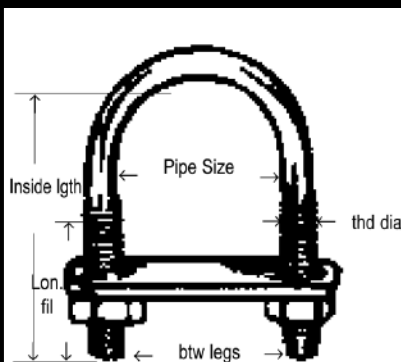

PLATED U-BOLTS (LONG)

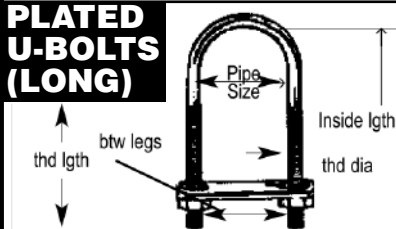

DIMENSIONS

CAT. #	PIPE SIZE	Thd lgth	Thd dia	Btw legs	Inside lgth
61180	1/4"	3/4"	1/4"	9/16"	1-3/8"
61182	1/2	7/8	1/4	1	1-3/4
61183	3/4	1-1/8	1/4	1-1/8	2
61184	1	1-1/8	1/4	1-1/2	2-3/4
61185	1-1/2	1-5/8	1/4	2	3-1/2
61186	1	1-1/4	5/16	1-1/2	2-1/2
61187	1-1/4	1-3/8	5/16	1-3/4	3
61188	1-1/2	1-3/8	5/16	2	3
61189	2	1-3/8	5/16	2-1/2	3-1/2
61193	2	1-1/4	3/8	2-1/2	3-1/2
61194	2-1/2	1-1/4	3/8	3	4
61195	3	1-1/4	3/8	3-1/2	4-1/2
61200	1	2	5/16	1-3/8	3-5/8
61201	1-1/4	2-1/2	5/16	1-3/4	4-1/8
61202	1-1/2	2	5/16	2	3-5/8
61203	1-1/2	2-1/2	5/16	2	4-5/8
61204	2	2-1/2	5/16	2-1/2	4-1/8
61205	2	2-1/2	5/16	2-1/2	5-1/8

UTILITY HARDWARE CENTRE

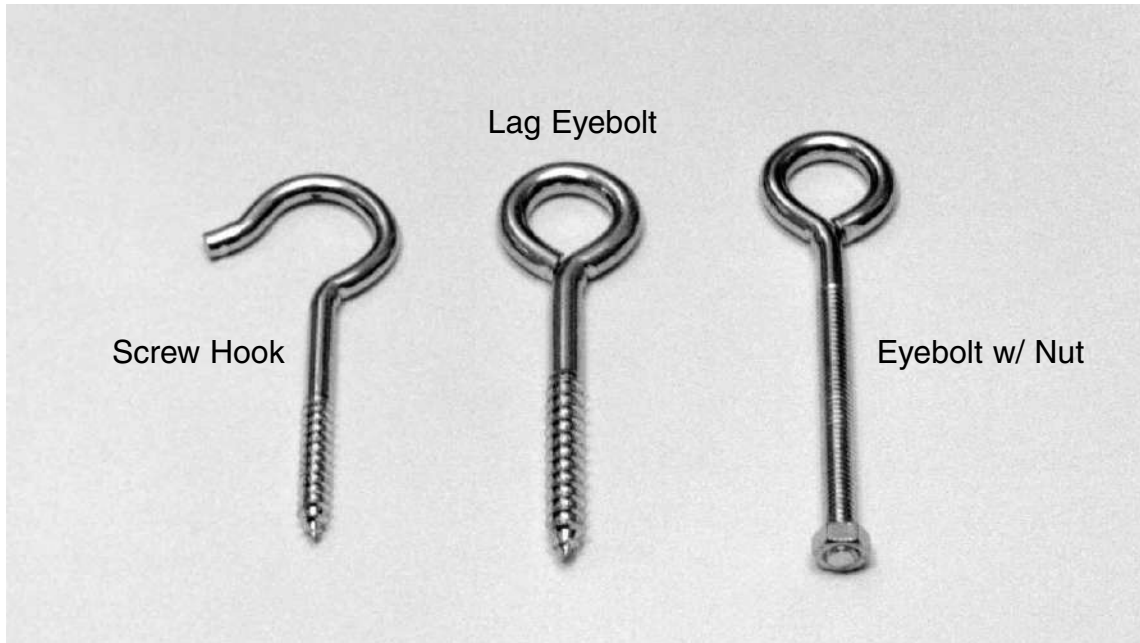



Screw Hooks, Lag Eye Bolts or Eye Bolts with Nut for Any Job
Do-It-Yourselfers, Contractors or Carpenters may have.

Opening Inventory—61006: includes POG 10605

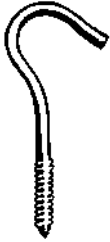
LAG EYE BOLTS AND SCREW HOOKS

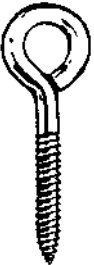
PLATED SCREWHOOK		DIMENSIONS			
		CAT. #	O.A. Length	THD. Length	Screw Size
		61210	2-1/16"	5/8"	#10
		61211	2-9/16	7/8	#8
		61212	3-3/8	1-1/8	#6
		61213	3-7/8	1-1/4	#4
		61214	4-1/8	1-1/2	#3
		61215	4-7/16	1-3/8	#2
		61216	5	1-1/2	#0

PLATED SCREW EYE		DIMENSIONS					
		CAT. #	Thd Dia	O.A. Lgth	Shank Lgth	Thd Lgth	Eye ID
		61230	1/4"	3"	2"	1-1/4"	9/16"
		61231	1/4	3-3/4	3-1/4	2	9/16
		61232	1/4	5	4	2	9/16
		61233	5/16	4	2-5/8	2	3/4
		61235	5/16	6	4-5/8	2	3/4
		61236	3/8	3	2-1/8	2	1-1/8
		61237	3/8	4-1/2	2-5/8	2	1-1/8
		61239	3/8	6	4-1/8	2	1-1/8

EYE BOLT w/Nut		DIMENSIONS					
		CAT. #	Thd Dia	O.A. Lgth	Shank Lgth	Thd Lgth	Eye ID
		61240	3/16	1-1/2"	1"	7/8"	5/16"
		61241	3/16	2	1-5/16	1-1/4	5/16
		61242	3/16	3	2-1/4	2	1/2
		61243	1/4	2	1-1/4	1	3/8
		61244	1/4	3	2-1/4	2	3/8
		61245	1/4	4	3	2	9/16
		61246	1/4	5	4	2-7/8	9/16
		61247	1/4	6	5	2-7/8	9/16
		61248	5/16	3	2-1/4	1-7/8	1/2
		61249	5/16	4	2-5/8	2	3/4
		61250	5/16	5	3-5/8	2-7/8	3/4
		61251	5/16	6	4-5/8	2-7/8	3/4
		61252	3/8	4	2-1/2	2-1/8	5/8
		61253	3/8	5	3-1/4	2-7/8	1
		61254	3/8	6	4-1/4	3-7/8	1
		61255	3/8	8	6-1/4	3-7/8	1
		61257	1/2	6	4	3-7/8	1-1/4
		61258	1/2	8	5-3/4	3-7/8	1-1/4

UTILITY HARDWARE CENTRE

SNAP HOOKS

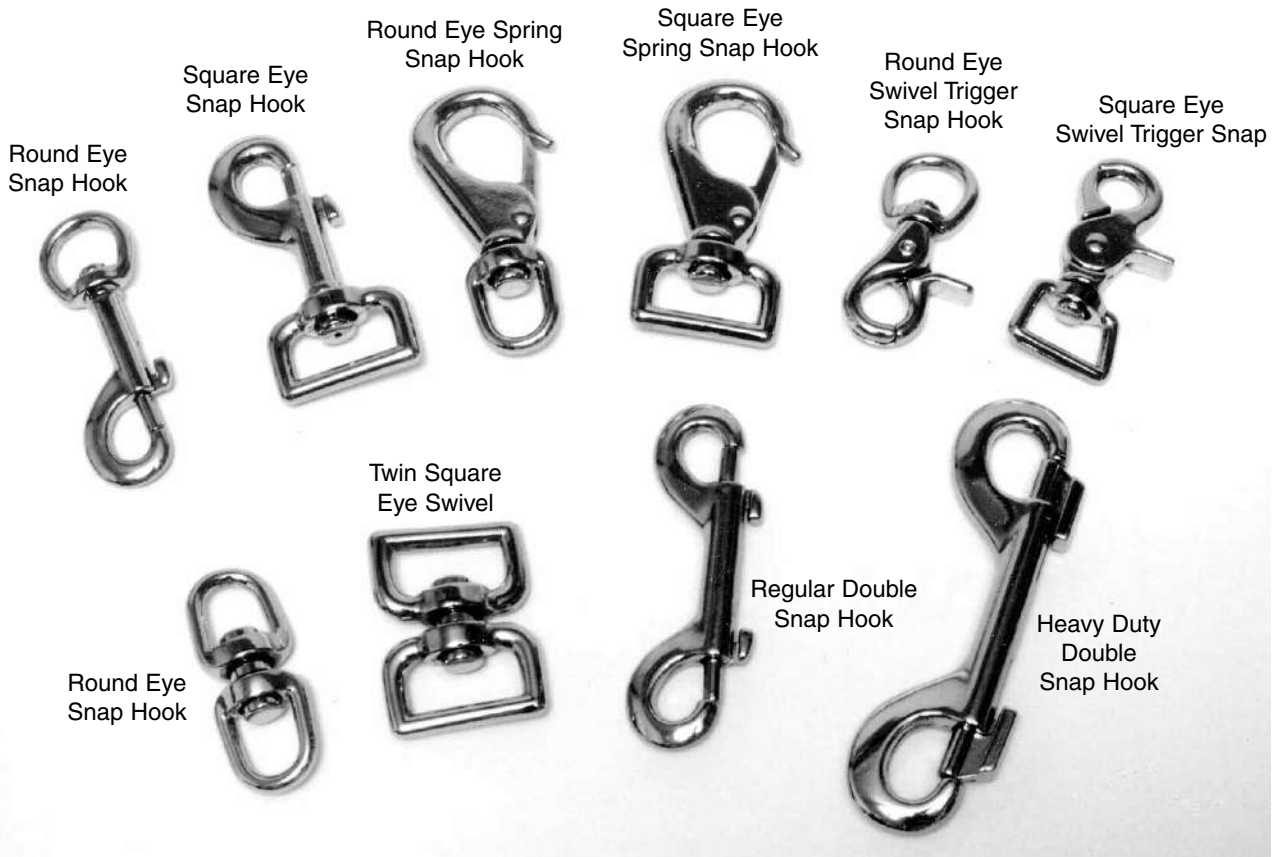

Our Complete Line of Snaps are Made of Die Cast Zinc Alloy and Plated to Prevent Rust.

Opening Inventory Snap Hook Centre-61007 includes POG 10606

	DIMENSIONS				
		CAT. #	Eye	Length	Mouth
ROUND EYE SNAP HOOK (Plated)		61260	3/8"	2"	3/16"
		61261	1/2	2-1/2"	3/16
		61262	1/2	3	7/32
		61263	5/8	3	5/16
		61264	5/8	3-1/2	3/8
SQUARE EYE SNAP HOOK (Plated)		61265	1/2"	2"	3/16"
		61266	5/8	2-1/2"	7/32
		61267	5/8	2-3/4	5/16
		61268	3/4	2-7/8	3/8
		61269	1	3-1/8	7/16
RD. EYE SPRING SNAP HOOK (Plated)		61270	1/2"	3-1/8"	7/16"
		61271	5/8	3-1/4	7/16
		61272	3/4	3-3/8	7/16
		61277	9/16	1-7/8	1/4
SQUARE EYE SPRING SNAP HK. (Plated)		61273	3/4	3-3/8	7/16
	61276	9/16	1-3/4	1/4	

	DIMENSIONS				
		CAT. #	Eye	Length	Mouth
RD. EYE, SWIVEL TRIGGER SNAP HOOK (Plated)		61280	3/4"	3-3/4"	5/8"
		61282	9/16	2	3/16
		61283	5/8	2-3/8	3/8
		61281	1	3-5/8	5/8
SQ. EYE, SWIVEL TRIGGER SNAP HK.		61284	3/4	2-5/8	3/8
DOUBLE ROUND EYE SWIVEL (Plated)		61287	1/2"	N/A	N/A
		61288	5/8	N/A	N/A
		61289	3/4	N/A	N/A
		61290	1	N/A	N/A
		61293	1"x1"	N/A	N/A
DOUBLE SNAP HOOK (Plated) Reg.		61295	3/8	3-1/2"	3/8"
		61296	3/8	4	7/16
		61297	1/2	4-5/8	1/2
		61298	3/8	3-1/2	3/8
DOUBLE SNAP HOOK (Plated) Heavy Duty		61299	3/8	4	7/16
		61300	1/2	4-5/8	1/2

UTILITY HARDWARE CENTRE

Eight Forged Steel Body and Steel Hook & Eye Turnbuckles ranging from 1/4" to 3/4". Work Load Limits from 400# to 3,000#.

Four Multi-Purpose Die Cast Body and Steel Hook & Eye Turnbuckles Ranging from 3/16" to 3/8".

Turnbuckles are Galvanized to prevent rust.

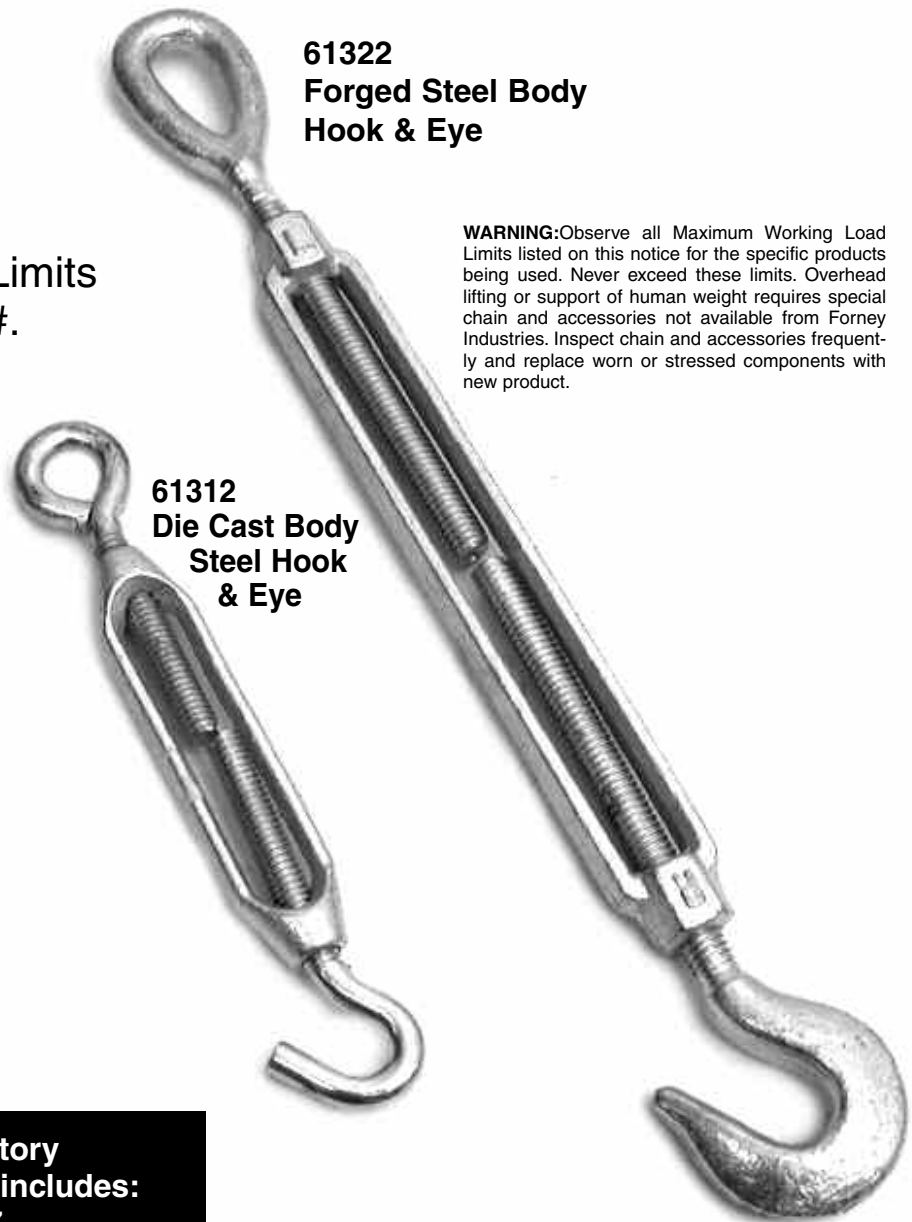

61322
Forged Steel Body
Hook & Eye

61312
Die Cast Body
Steel Hook
& Eye

WARNING: Observe all Maximum Working Load Limits listed on this notice for the specific products being used. Never exceed these limits. Overhead lifting or support of human weight requires special chain and accessories not available from Forney Industries. Inspect chain and accessories frequently and replace worn or stressed components with new product.

**Opening Inventory
Turnbuckles-61008 includes:
POG 10607**

CAT. #	Size	DIMENSIONS			
		L1	L2	B	M
61310	3/16"	2-3/16"	1-3/4"	5/16"	9/32"
61311	1/4	3-1/8	2-1/32	13/32	11/32
61312	5/16	3-11/16	2-3/8	15/32	7/16
61313	3/8	4-1/16	2-3/4	9/16	1/2

CAT. #	Size	Working Load	DIMENSIONS		
			L1	Length	Wt
61320	1/4"	400	4"	8-1/4"	.3
61321	5/16	700	4-1/2	9-9/16	.5
61322	3/8	1,000	6	11-7/8	.75
61323	1/2	1,500	6	13-5/16	1.5
61324	1/2	1,500	9	16-5/16	1.75
61325	1/2	1,500	12	19-5/16	2.18
61326	5/8	2,250	8	15-1/2	2.63
61327	3/4	3,000	8	17	3.75

TURNBUCKLES



ABRASIVE GRINDING WHEELS

GRINDING WHEELS FOR ANGLE HEAD GRINDERS

Aluminum oxide metal-cutting wheels. Designed for metal-cutting, metal abrasion, body work, metal fabrication, weld grinding & general repair work. Abrasive wheels must wear away gradually to stay "sharp" and perform properly. Proper balance of hardness and rates of wear, give most economical performance. Manufactured entirely of top grade materials. Tested to meet all safety code requirements. Some general purpose wheels have patented throw away hub. Rate of wear or life of the wheel determined by the type of bonding material (hardness) in the wheel. A wheel with proper hardness will wear away just fast enough to remain "sharp". An excessively hard wheel will become dull & glazed because it doesn't wear away fast enough & therefore will cut slowly and waste your time.

TYPE 27 ABRASIVE WHEEL HUBLESS

General Purpose, 24 grit Aluminum Oxide. Fiberglass Reinforced.

Cat. #	SIZE	Max. rpm
71810	4" x 1/16" x 5/8"	15,300
71812	4 1/2" x 1/16" x 7/8"	13,300
71825	5" x 1/16" x 7/8"	12,300
71828	7" x 1/16" x 7/8"	8,500
71829	6" x 1/16" x 7/8"	10,000
71888	4 1/2" x 1/4" x 7/8"	13,300
72307	4" x 1/4" x 5/8"	15,300
72308	4 1/2" x 1/4" x 7/8"	13,300
74311	4 1/2" x 1/8" x 7/8"	13,500
74312	4" x 1/8" x 5/8"	15,300
74313	5" x 1/8" x 7/8"	12,200
74314	7" x 1/8" x 7/8"	8,600
74315	9" x 1/8" x 7/8"	6,600
82330	7" x 1/4" x 7/8"	8,500
82332	9" x 1/4" x 7/8"	6,500
82333	5" x 1/4" x 7/8"	13,300

Special Bulk Quantity
Pricing Available



TYPE 27 ABRASIVE WHEEL WITH HUB

General Purpose, 24 grit Aluminum Oxide. Fiberglass Reinforced.

Cat. #	SIZE	Max. rpm
82331	7" x 1/4" x 5/8" - 11NC	8,500

TYPE 28 ABRASIVE WHEEL WITH HUB

General Purpose, 24 grit Aluminum Oxide. Fiberglass Reinforced.

Cat. #	SIZE	Max. rpm
71826	7" x 1/4" x 7/8"	8,600
82334	7" x 1/4" x 5/8" - 11NC	8,600



GRINDING WHEEL ACCESSORIES

82326 RE-USABLE WHEEL ADAPTER

For hubless, depressed centre, abrasive wheels, 5/8" - 11NC with locking nut and allen wrench.

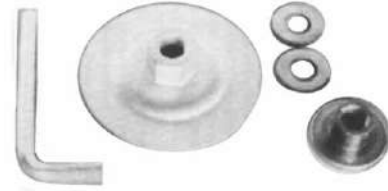

82327 NON-RE-USABLE WHEEL ADAPTER

Adapter for all 7" and 9" grinder Depressed Centre Wheels. 5/8" - 11 NC

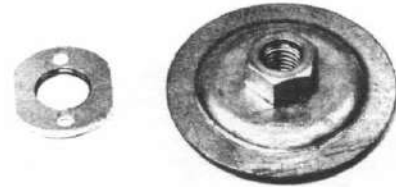

SPIRAL SANDING DISC

These discs are designed not to plug up when used for cutting concrete and other soft materials such as animal hoofs etc. #24 grit.

Cat. #	SIZE	Grit	Max. rpm
82295	4 1/2" x 7/8"	24	13,700
82297	7" x 7/8"	24	8,500
82298	5" x 7/8"	24	8,500



72386 MANDREL SET

Suited for small cut-off wheels with 1/4 and 3/8 arbors, 1/4" shank



71798 CUT - OFF WHEEL KIT

Three 3" cut-off wheels (3" x 1/16" x 1/4", 3" x 1/16" x 3/8" and 3" x 1/8" x 1/4") and drill adapter mandrel. Skin packed.



Wear eye & face protection when using power wheels.

ABRASIVE FLAP DISCS

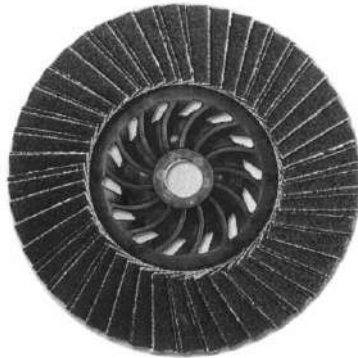

XForce Turbo Discs - Trimmable

Cat. #	Diameter	Grit
71970	4 1/2" (5/8"-11")	40
71971	4 1/2" (5/8"-11")	60
71972	4 1/2" (5/8"-11")	80
71973	4 1/2" (5/8"-11")	120
71976	5" (5/8"-11")	40
71977	5" (5/8"-11")	60
71978	5" (5/8"-11")	80
71979	5" (5/8"-11")	120

Xforce turbo discs are made using a **double** flap configuration which means there is more zirconium sandpaper coming in contact with the material you are working on. This also provides an **excellent removal** rate and does not affect the **life** of the disc.

71969 TURBO FLAP WHEEL DISPLAY (24 pc)

4 ea. of 71970, 71971, 71972, 71973

2 ea. of 71976, 71977, 71978, 71979

High Speed Flap Discs

TYPE 29 (CONICAL) MAX. RPM 13,500



BLUE ZIRCONIA FLAP DISCS

For 4" & 4-1/2" Angle Grinders. Cut Fast & Outlast Sanding Discs 10 to 1. Great Flexibility. Ideal for Rough or Fine Finishing.*High Density Discs Ideal for Extra Tough Jobs.

Cat. #	Diameter	Arbor Size	Grit
71983	4"	5/8"	120
71984	4 1/2"	7/8"	120
71985	4 1/2"	7/8"	40
71986	4 1/2"	7/8"	60
71987	4 1/2"	7/8"	80
71988	7"	7/8"	40
71989	7"	7/8"	60
71990	7"	7/8"	80
71991	4"	5/8"	40
71992	4"	5/8"	60
71993	4"	5/8"	80
71994	5"	7/8"	40
71995	5"	7/8"	60
71996	5"	7/8"	80
71997	5"	7/8"	120
71998	7"	7/8"	120

BENCH GRINDER WHEELS & ACCESSORIES

TYPE 1 BENCH GRINDER WHEELS

Vitrified bond, aluminum oxide. Designed for most stationary bench grinders. For general grinding and sharpening applications on mild steel. 1" Arbor hole with adapter reducer for 1/2", 5/8" & 3/4" arbors. Not for carbide applications.

Cat. #	Diameter	Thickness	Grit	R.P.M. max.
72392	5"	3/4"	36	4,966
72393	5"	3/4"	60	4,584
72394	5"	3/4"	80	4,584
82420	6"	1"	36	4,100
82421	6"	1"	60	4,100
82419	6"	1"	80	4,100
82422	6"	3/4"	36	4,100
82423	6"	3/4"	60	4,100
82431	6"	3/4"	80	4,100
82424	7"	1"	36	3,600
82425	7"	1"	60	3,600
82432	7"	1"	80	3,600
82426	8"	1"	36	2,865
72397	8"	1"	60	2,865
82433	8"	1"	80	2,865



72395• REDUCING BUSHINGS FOR 3/4" THICK WHEELS

72399• REDUCING BUSHINGS FOR 1" THICK WHEELS

Heavy duty plastic. Designed so that a 1" arbor grinding wheel will fit a 1/2", 5/8", or 3/4" shaft. Set of 3.



72390 GRINDING WHEEL DRESSER

Huntington type (#0), hooded cast iron. For dressing grinding wheels up to 10" diameter and 2" face. Overall length 10-1/2", weight 2 lbs.



72391• REPLACEMENT CUTTERS (SKIN-PACKED)

Made of carbon steel with long lasting, sharp teeth. Hardened to insure long service and proper dressing action. Set of 2 spacers & 4 cutters. 1-1/4" diameter, 1/4" hole, .426 face width. For use with above dresser.



Wear eye & face protection when using power tools

ABRASIVE SANDING DISCS



73148 Deluxe Universal Spanner wrench

Spanner wrench for grinders and sanding disc backing pads. Hardened steel. Fits most common sizes.

ABRASIVE SANDING DISCS

For edge sanding solder sanding or oil filling operations. "Shape Controlled" to resist the effect of humidity and of temperature. Aluminum Oxide mineral, heavy all-fibre backing. Close coat, resin bonded. Balanced to ensure high-speed performance.



Cat. #	Diameter	Adapter Size	Grit
71749	4"	5/8"	16
71750	4"	5/8"	24
71751	4"	5/8"	36
71752	4"	5/8"	50
71753	4"	5/8"	80
71755	4"	5/8"	120
71736	4-1/2"	7/8"	16
71737	4-1/2"	7/8"	24
71738	4-1/2"	7/8"	36
71739	4-1/2"	7/8"	50
71740	4-1/2"	7/8"	80
71742	4-1/2"	7/8"	120
71757	5"	7/8"	16
71758	5"	7/8"	24
71759	5"	7/8"	36
71760	5"	7/8"	50
71761	5"	7/8"	80
71763	5"	7/8"	120
71765	7"	7/8"	16
71766	7"	7/8"	24
71767	7"	7/8"	36
71768	7"	7/8"	50
71769	7"	7/8"	80
71771	7"	7/8"	120

71720 OPENING INVENTORY EMERY CLOTH AND SAND SCREEN

Ideal for Polishing Machined Shafts and Roughing Plumbing Pipe Before Soldering or Gluing. Easy and Economical to Use. Tear off as needed and store. Contains one each of the following.

SAND SCREEN BENCH ROLL

Silicon Carbide. Fast cutting. Long Lasting. Doesn't load up

Cat. #	Size	Grit
71725	1-1/2" x 9'	80
71726	1-1/2" x 9'	120
71727	1-1/2" x 9'	180
71728	1-1/2" x 9'	320

EMERY CLOTH BENCH ROLL

Aluminum Oxide

71803	1" x 10 yds	80
71804	1" x 10 yds	120
71805	1" x 10 yds	180
71806	1" x 10 yds	320



ABRASIVE CUTTING WHEELS

CUT-OFF WHEELS

Most popular sizes for metal and masonry are available in 1/8" or 3/32" thickness. Extra-heavy reinforcement for added safety at high speeds in all off-hand cutting applications. Made to meet or exceed all safety requirements. Please observe maximum RPM limits. Make sure material being cut is not allowed to twist and bind against the wheel. If a hand-held machine is used, keep it straight and do not twist the cut-off wheel.

Cat. #	Diameter	Thickness	Adapter Size	Max. RPM
METAL				
82336	7"	3/32"	7/8"	8,600
82337	7"	3/32"	5/8"	8,600
82338	8"	3/32"	5/8"	7,500
82339	9"	3/32"	7/8"	6,500
82340	8"	3/32"	1"	7,500
72369	10"	3/32"	1"	6,200
72370	12"	3/32"	1"	5,100
82345	12"	1/8"	20mm	6,300
82349	12"	5/32"	1"	6,300
82350	14"	1/8"	1"	5,400
82355	14"	1/8"	20mm	5,400
72371	14"	3/32"	1"	4,400
72372	16"	1/8"	1"	3,800
71865	12"	7/64"	1"	5,100
71866	14"	7/64"	1"	4,400
CONCRETE & MASONRY				
72373	7"	1/8"	5/8"	8,600
82448	8"	1/8"	5/8"	7,500
72376	12"	1/8"	1"	5,100
82344	12"	1/8"	20mm	6,300
82347	14"	1/8"	20mm	5,400
72377	14"	1/8"	1"	5,400
ASPHALT				
82348	12"	5/32"	20mm	6,300
82352	14"	5/32"	1"	5,400

Special Bulk Quantity
Pricing Available



STEEL CUT-OFF WHEELS

Small diameter reinforced cut-off wheels for use on straight shaft and die grinders. Extra strength and safety for high-performance cutting and notching. Free cutting allowing the operator to work with a minimum of pressure for best control and lowest load on the tool.

Cat. #	Diameter	Thickness	Adapter Size	Max RPM
71780	3"	1/16"	1/4"	25,000
71782	3"	1/16"	3/8"	25,000
71784	3"	1/8"	1/4"	25,000
71786	3"	1/8"	3/8"	25,000
71788	4"	1/16"	3/8"	25,000
71790	4"	1/8"	3/8"	25,000
71792	4"	1/16"	5/8"	19,000
71794	4 1/2"	1/16"	7/8"	13,200
71813	3"	1/32"	3/8"	25,000
71815	4"	1/32"	3/8"	25,000
71922	3"	.035"	3/8"	25,000
71923	4 1/2"	.040"	7/8"	13,200
71924	5"	.040"	7/8"	12,000
71925	4.5"	5/64"	7/8"	13,200
71926	4"	5/64"	7/8"	12,200
71797	6"	.040"	7/8"	10,000
81886	7"	1/16"	5/8"	8,500
81887	7"	1/16"	7/8"	8,500

Special Bulk Quantity
Pricing Available



WIRE BRUSH SAFETY INFORMATION AND USAGE RECOMMENDATIONS

IMPORTANT: All operators must read this information thoroughly and completely before using the brush!

Warning: In normal power brushing operations, the material that is being removed, such as burrs, scale, dirt, weld slag, or other residue, will fly off the brush with considerable force along with the brush filaments which break off due to fatigue.

The potential for serious injury exists for both the brush operator and others in the work area (possibly 50 or more feet from the brush). To protect against this hazard, before rotating the brush, during rotation, and until rotation stops, OPERATORS AND OTHERS IN THE AREA MUST WEAR SAFETY GOGGLES OR FULL FACE SHIELDS WORN OVER SAFETY GLASSES WITH SIDE SHIELDS, ALONG WITH PROTECTIVE CLOTHING.

You must follow all operator and safety instructions, as well as common safety practices, which will reduce the likelihood or severity of physical injury.

Summary-Power Brush Safety requirements

- Safety Goggles:** Safety goggles or full face shields worn over safety glasses with side shields MUST BE WORN BY ALL OPERATORS and OTHERS IN THE AREA of power brush operations. Comply with the requirements of ANSI Z87.1-1979 "Occupational Eye and Face Protection."
- Guards:** Keep all machine guards in place.
- Speeds:** Observe all speed restrictions indicated on the brushes, containers, labels, or printed in pertinent literature. "MSFS" or "Max. SFS" means Maximum Safe Free Speed (R.P.M.)—spinning free with no work applied. For reasons of safety the "MSFS/Max. SFS" should not be exceeded under any circumstances.
- Safety Standard:** Comply with the Safety Standards of the Industrial Division of the American Brush Manufacturers' Association and the American National Standards Institute Standard ANSI B165.1-1985 "Safety Requirements-Power Brushes" and ANSI B165.2-1982 "Safety Requirements-Power Brushes-Wood, Plastic, or Composition Hubs."
- Protective Equipment:** Appropriate protective clothing and equipment (such as gloves, respirator, etc.) must be used where a possibility of injury exists that can be prevented by such clothing or equipment.
- Before Starting Brush:** Use eye protection and safety equipment. Inspect brush for rust, damage, speed limit, etc. If no-bad speed marked on the power tool is higher than the brush speed limit, do not mount brush. Inspect and log machine to assure the brush is mounted properly and securely, machine guards are in place, no vibration, etc. Run machine at operating speed for at least one minute before applying work-DO NOT STAND IN FRONT OR IN LINE WITH BRUSH.

WARNING

failure to observe safety precautions may result in **INJURY**

AVAILABILITY OF ANSI STANDARDS

On this slip reference is made to these ANSI Standards, ANSI B165.1-1985, ANSI B165.2, ANSI Z87.1-1979. Copies of these standards are available at Public Libraries and from American National Standards Institute, Inc. (ANSI), 1430 Broadway, New York, NY 10018, or American Brush Manufacturers' Association, 1900 Arch Street, Philadelphia, PA 19103 (B165.1 and B165.2, only).

Many brush manufacturers mark some safety warnings, recommendations, and usage restrictions directly on the product. It is not always practical to include even the limited safety information on the brush itself. Therefore, THE OPERATOR MUST READ and FOL-

LOW ALL INSTRUCTIONS SUPPLIED IN OR ON THE PRODUCT CONTAINER AS WELL AS THOSE MARKED ON THE PRODUCT ITSELF. The operator should also refer to the safety and operation information printed in the brush manufacturer's catalog and other literature.

Pressure: Avoid excessive pressure when using a power brush. Excessive pressure causes over-bending of the filaments and heat build-up resulting in filament breakage, rapid dulling, and reduced brush life. Instead of greater pressure on a brush, it is suggested that you try: (1) a brush with a more aggressive cutting action (increased wire size, decreased filament length, change to a different brush type, i.e., knot type instead of crimped wire type), or (2) higher speed (increased R.P.M., increased brush diameter). **IMPORTANT NOTE: NEVER EXCEED the recommended MAXIMUM SAFE FREE SPEED R.P.M. (MSFS/Max. SFS) rating of the brush.** See Fig. 1

Figure 1: Pressure

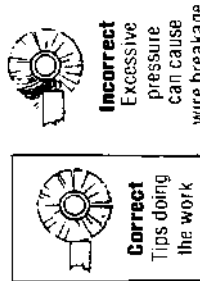

Self-Sharpening: When using wire wheel brushes, periodically reverse the direction of rotation to take advantage of the self-sharpening action that will result. This may be accomplished by removing the brush from the spindle and turning it side for side, and remounting securely. See Fig. 2.

Figure 2: Self-sharpening

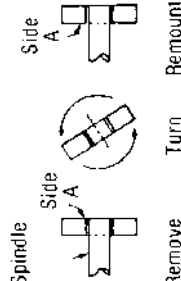

Brushing Problems: Do Not Allow Unsafe Conditions to Continue- Occasionally, due to worn bearings, a bent spindle, an unusual application, operator abuse, or inappropriate use, a brush may fail. A brush which is not received in acceptable condition for trouble-free operation may also fail. Do not use or continue to use a failed brush or one which is functioning improperly (i.e., throwing filaments, out-of-balance, etc.) as this increases the possibility for further brush failure and hazard of injury. The cause of the failure should be evaluated and corrected.



MEMBER
Safety Committee,
American Brush
Manufacturers' Association

This information is based on the collective experience of the ABMA Industrial Division members and provided solely as a public service for the guidance of the users of the members' products. These recommendations are not necessarily complete with respect to any particular application and common sense safety considerations should be adhered to generally. Any applicable federal, state, local law or regulation must be strictly adhered to, and is controlling over any recommendation contained herein.

GRINDING WHEEL SAFETY INFORMATION

A WORD OF CAUTION

Regarding types 27 & 28 (depressed centre) wheels
If used with nonstandard adapters, which have a deeper and smaller diameter offset, there is a danger of breaking out around the arbor hole. Be sure to use standard adapters with Type 27 and 28 wheels. See illustration for correct and incorrect assembly.

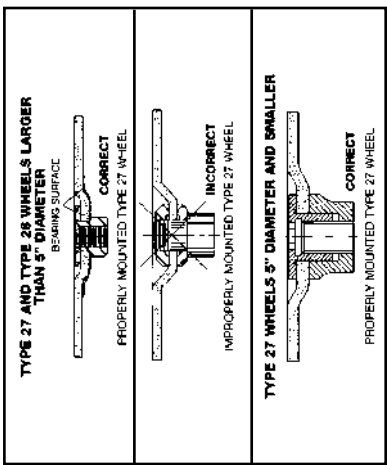

safety guide DO

- Always handle and store wheels in a careful manner.
- Always visually inspect all wheels before mounting for possible damage in transit. Vitrified wheels can be rung and should emit a clear bell-like tone if not cracked. Resinoid and rubber bonded wheels can only be checked visually.
- Always check maximum operating speed established for wheel against machine speed.
- WARNING: Don't use Grinding or Cut-Off Wheels on High Speed Air or Electric Sanders.**
- Always check mounting flanges for equal and correct diameter. (Should be at least 1/3 diameter of the wheel and relieved around hole.)
- Always use mounting bolters if supplied with wheels.
- Always be sure rest for floor stand grinder is properly adjusted. (Centre of wheel or above; no more than 1/8" away from wheel.)**
- Always use a guard covering at least one-half of the grinding wheel.
- Always allow newly mounted wheels to run at operating speed, with guard in place, for at least one minute before grinding. When setting up automatic machines, make a test run with the wheel stopped.
- Always wear safety glasses and face protection when grinding.**
- Always turn off coolant before stopping wheel to avoid creating an out-of-balance condition.

safety guide DON'TS

- Don't use a wheel that has been dropped.
- Don't force a wheel onto the machine or alter the size of the arbor hole. Don't use a wheel that fits the arbor too loosely, if the wheel doesn't fit the machines, get one that does.
- Don't exceed maximum operating speed established for the wheel, which are not clean.
- Don't use mounting flanges which are warped, nicked, sprung, or which are not clean.
- Don't tighten the mounting nut excessively. **On multiple screw mountings, 15-foot pounds per screw is usually enough.**
- Don't grind on the side of the wheel unless wheel is specifically designed for that purpose.
- Don't start the machine until the wheel guard is in place.
- Don't jam the work into the wheel.
- Don't stand directly in front of a grinding wheel when a grinder is started.**
- Don't grind material for which the wheel is not designed.

- Be sure flanges are clean and straight.
- Be sure flanges are of same diameter.
- Be sure flanges are AT LEAST 1/3 the diameter of the wheel.
- Be sure flanges have proper clearance at arbor.

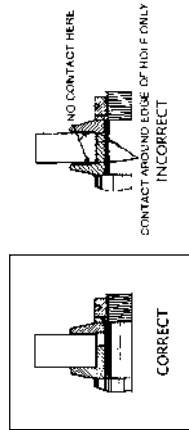

5. If the wheel fits too loose on the arbor it can become badly out of true and will noticeably "pound." Arbor hole should be .006 to .010 inches larger than the arbor.
6. Be sure there are good "bolters" between the wheel and the flanges.

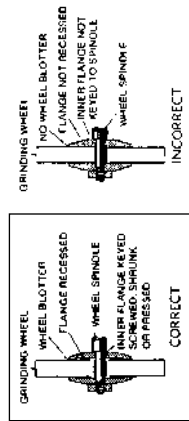

7. Be sure the flanges are tightened securely but not too tightly-to avoid springing the flanges.

CUT-OFF WHEELS ARE EFFICIENT TOOLS IF PROPERLY OPERATED

MACHINE REQUIREMENTS

- MUST** have adequate power

Suggested Power Range for Cut-Off Machines

Diameter of Wheel	Wheel Speed	Wheel Speed	Minimum Dry Cutting Ft. Per Min.	Minimum Suggested Peripheral Speed
10"	10,000-14,000	8,000-10,000	2 to 3 h.p.	2 to 3 h.p.
12"	10,000-14,000	8,000-10,000	3 to 5 h.p.	3 to 5 h.p.
14"	10,000-14,000	8,000-10,000	5 to 10 h.p.	5 to 10 h.p.

- MUST** maintain straight line cuts.
- MUST** provide rigid support and "hold down" of piece being cut.
- Side pressure **MUST** be avoided.
- MUST** have proper drive flanges.



- MUST** have adequate guard over the wheel.
- MUST** be maintained in first class condition.

All machine features should be frequently checked and substandard conditions corrected to insure efficiency and safety.

BASIC ABRASIVE CUTTING PROCEDURE



- Be sure work piece is securely held down. (Both sides of the cut, if practical.)
- Start the cut gently-Do not "bump" the wheel to start a cut.
- Feed the wheel through the work as fast as possible without slowing the wheel in the cut. Don't "baby" the wheel through the cut.

DIAMOND CUT-OFF BLADES

DIA-HARD DIAMOND CUT-OFF BLADES

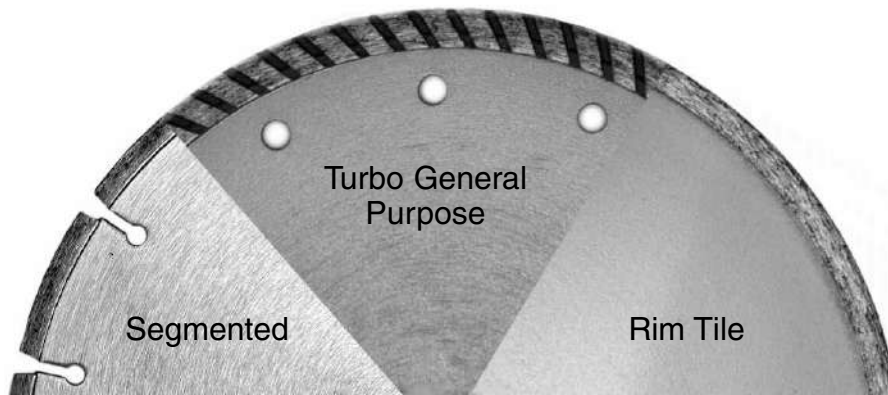
Premium Quality, German Engineered for Efficient Long Lasting Use. Includes Attractive Packaging and Comprehensive Labeling Designed to Highlight the Remarkable Cutting Abilities of These Fine Blades. Can be Used "Dry", but Recommend "Wet".



	SIZE	TYPE	ARBOR WIDTH	CAT#
	4"	Rim Tile	5/8" or 20mm x 1/16"	71556
	4-1/2"	Rim Tile	7/8" or 5/8" x 1/16"	71557
	7"	Rim Tile	5/8" or 7/8-Diamond x 1/16"	71558
<i>(High Diamond Concentration for Cutting Tile Cleanly)</i>				
	4"	Turbo General Purpose	5/8" or 20 mm x 5/64"	71560
	4-1/2"	Turbo General Purpose	7/8" or 5/8" x 5/64"	71561
	7"	Turbo General Purpose	5/8" or 7/8-Diamond x 5/64"	71562
<i>(Fast Cutting Quality Blades for Brick, Block, Stone, Marble, Granite and other Building Materials)</i>				
	12"	Laser Segmented	1" or 20 mm x 3/32"	71566
	14"	Laser Segmented	1" or 20 mm x 5/32"	71568
<i>(Laser Welded Excellent Diamond Quality and Density for Large Tough Jobs: Cured Reinforced Concrete, Brick, Stone Block & other Building Materials. Please note: None of these are designed for use on "GREEN" concrete.)</i>				

Cutting "Depth" (Width of Diamond Embedded Segment):

71556 to 715623/16"
 715661/4"
 715685/16"

POLISHING & BUFFING WHEEL, TRIMMABLE DISCS

POLISHING BONNET

822545" Diameter	822507" Diameter
-------------------------------	-------------------------------

Attachment type hook and loop. For use with back pad for polishing, applying and removing wax.



82250

72040 6" BUFFING WHEEL

Used to clean and polish steel, stainless steel, brass and copper. These wheels can be used with bench grinders and drills. 1/2" thick with 1/2" arbor. Maximum 3,600 R.P.M.



72040

82260 UNI-BONDED ABRASIVE DISC ASSORTMENT ALUMINUM OXIDE TRIM-KUT

3" Diameter Discs packaged in an attractive display carton which contains 2 of each disc plus the mandrels and adapters. *Items: 82262, 82263, 82264, 82265 and 82266.*

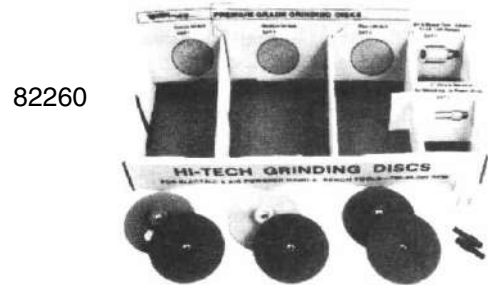

82260

82266 TRIM-KUT ADAPTER

For use with angle grinders 7/16-20 NC thread.



82266

82265 MANDREL FOR "TRIM-KUT" DISCS 1/4"



82265

SURFACE PREP PADS

Cat. #	Diameter	Grit
71903	2"	Medium
71904	2"	Coarse
71905	2"	Fine
71906	3"	Medium
71907	3"	Coarse
71908	3"	Fine

Cat. #	Diameter	Item
71914	2"	Prep Pad Holder
71915	3"	Prep Pad Holder

Cat. #	Diameter	Grit	Max RPM
82262	3"	36	21,000
82263	3"	60	22,000
82264	3"	120	22,000



82262

TRIMMABLE GRINDING DISCS NO BACKING PAD REQUIRED

"Trim-Kut" A super-fast cutting disc. Resistant to snagging, cracking. Long life. Superior stock removal. Grinds remarkably cool. Grind wood, metal, plastic, ceramics, composites, paint, rust, non-ferrous metals, glass, stone, fiberglass, welds, etc. Direct sparks down and away from body. Outlasts Resin Fiber discs 6 to 1. Use with electric drills and most grinders. No backing pad required - just spin on and go! Outer surface of disc normally becomes dull first. This may be trimmed. Operate grinder with the back surface of the disc inclined approximately 5 - 15° against a secured piece of scrap metal. Exert a slight amount of pressure toward the operator while operating at normal RPM. Store at room temperature and humidity. Avoid freezing.

ABRASIVE FLAP WHEELS

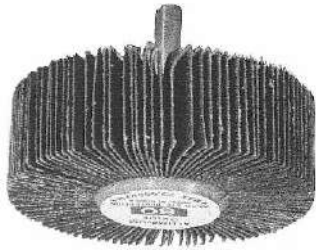

MOUNTED FLAP WHEELS

A convenient, effective abrasive system for removing unwanted material from around objects and hard to reach locations where rigid abrasives will not do the job. All flap wheels come with a 1/4" shank for use on drills and other chuck-mounted equipment. 3 grit ranges. 4 diameters.

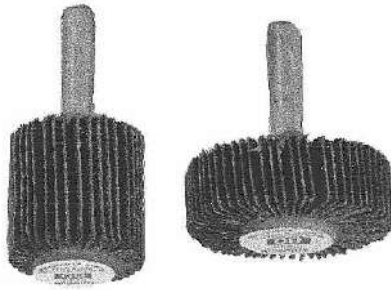

Cat. #	Carded #	Grit	Cat. #	Carded #	Grit
SIZE 2" x 1"			SIZE 3" x 1"		
71688	60184	60	71685	60181	60
71689	60185	80	71686	60182	80
71690	60186	120	71687	60183	120
SIZE 1" x 1"			SIZE 1 1/2" x 1/2"		
71694	60190	60	71691	60187	60
71695	60191	80	71692	60188	80
71696	60192	120	71693	60189	120



71681 DISPLAY TRAY

Contains one each of the items listed below.

71691	71692	71693
71694	71695	71696



71680 DISPLAY TRAY

Contains one each of the items listed below.

71685	71686	71687
71688	71689	71690

71682 DISPLAY TRAY

Contains one each of the 12 catalogue items listed separately on this page. (71680 - 71681)

ABRASIVES AND POWER BRUSHES

72718 WIRE BRUSH OPENING DISPLAY KIT

Contains 36 Wire Brush items and includes a generic 12" x 24" Planogram and header cards
2 each of numbers: 10591 - 10592 - 10593 - 10594
Plus 36 hooks # 10231

PACKAGED WIRE WHEELS & CUP BRUSHES

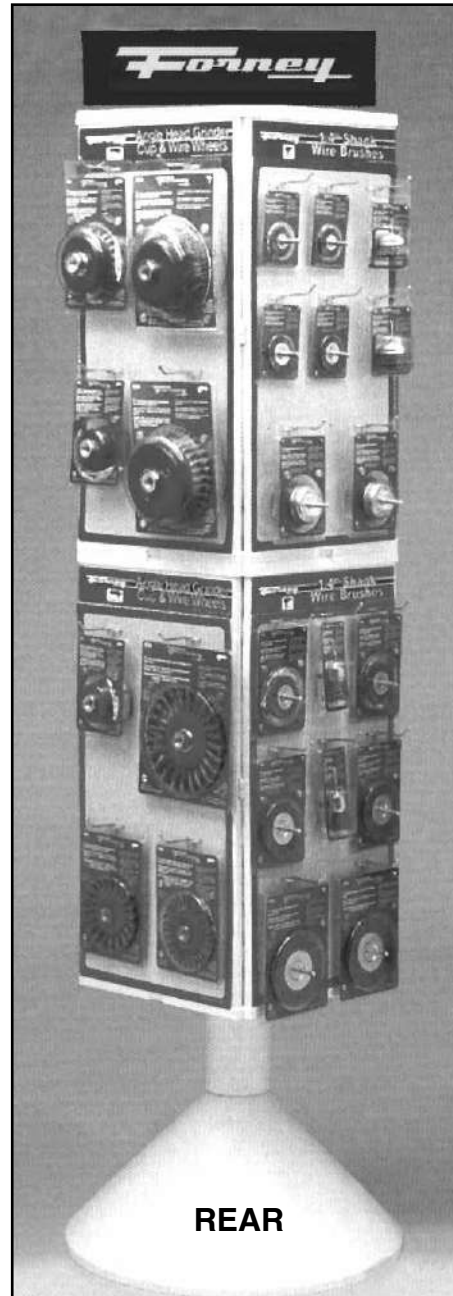
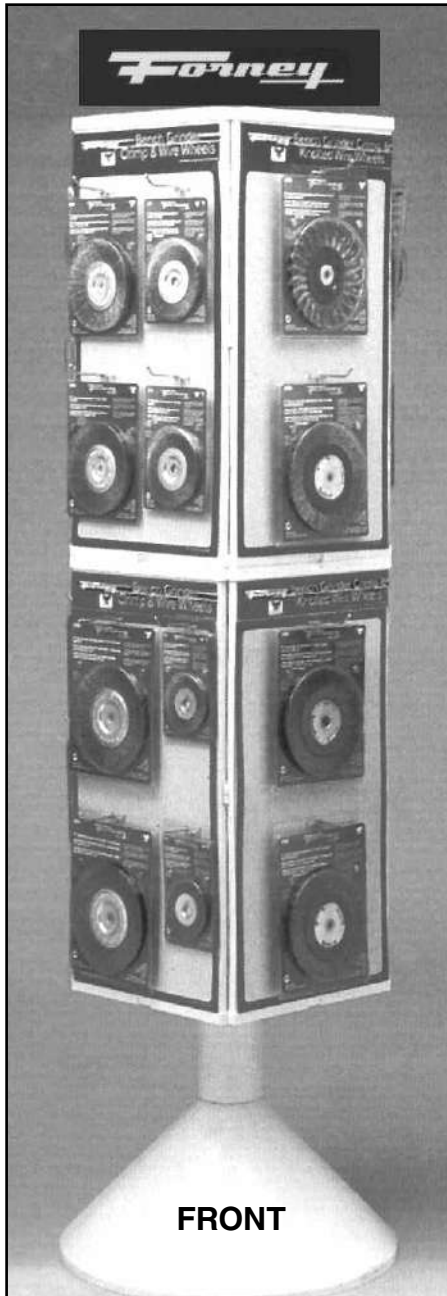

ABRASIVES AND POWER BRUSHES

FORNEY PACKAGED WIRE BRUSH CENTRE

1/4" Shaft Mounted Brushes and Bench Grinder Brushes for Home Shop Use. Bench Grinder and Angle Head Wire Brushes for Light Industrial Use. Packaged in Clam Shells with Point-of-Purchase Information, Bar Codes and Safety Instructions.

OPENING INVENTORIES AND PANEL DISPLAYS Cat# 72720 (Not Illustrated) METRIC DISPLAY

72721



PLAN-O-GRAM 1/4" shank Wire Brush

72722



PLAN-O-GRAM Bench Wheels Red Cap

72723



PLAN-O-GRAM Bench Wheels Red Cap

72724



PLAN-O-GRAM Angle Grinders

PACKAGED WIRE WHEELS & CUP BRUSHES

ABRASIVES AND POWER BRUSHES

POWER BRUSHES

NEW! PACKAGED WHEELS AND BRUSHES

Cat#	Description	RPM
1/4" SHANK WHEELS & BRUSHES		
72725	1-1/2" coarse crimp wire wheel	6,000
72726	1-1/2" fine crimp wire wheel	6,000
72727	2" coarse crimp wire wheel	6,000
72728	2" fine crimp wire wheel	6,000
72729	2" coarse crimp wire cup	6,000
72730	2" fine crimp wire cup	6,000
72731	3" coarse crimp wire cup	6,000
72732	3" fine crimp wire cup	6,000
72733	2-1/2" coarse crimp wire wheel	6,000
72734	2-1/2" fine crimp wire wheel	6,000
72735	3" coarse crimp wire wheel	6,000
72736	3" fine crimp wire wheel	6,000
72737	1" coarse crimp end brush	6,000
72738	1" fine crimp end brush	6,000
72739	4" coarse crimp wire wheel	6,000
72740	4" fine crimp wire wheel	6,000



72725



72731



72737



72733

OPEN ARBOR WHEELS BENCH GRINDING WHEELS

72741	5"x 1/2-5/8 arbor coarse crimp wire wheel	6,000
72742	4"x 1/2 arbor coarse crimp wire wheel	6,000
72743	5"x 1/2-5/8 arbor fine crimp wire wheel	6,000
72744	4"x 1/2 arbor fine crimp wire wheel	6,000
72745	6"x 1/2-5/8 arbor coarse crimp wire wheel	6,000
72746	3"x 1/2 arbor coarse crimp wire wheel	6,000
72747	6"x 1/2-5/8 arbor fine crimp wire wheel	6,000
72748	3"x 1/2 arbor fine crimp wire wheel	6,000
72749	6"x 1/2-5/8 arbor coarse knot wire wheel	6,000
72750	6"x 1/2-5/8 arbor coarse crimped wire wheel narrow face	6,000
72751	6"x 1/2-5/8 arbor fine wire wheel narrow face	6,000
72752	6"x 1/2-5/8 arbor coarse crimped wire wheel wide face	6,000



72742



72743



72751



72752

THREADED ARBOR WHEELS & BRUSHES FOR ANGLE-HEAD GRINDERS

72761	5"x 5/8 arbor coarse crimped wire wheel narrow face	6,000
72762	8"x 5/8 arbor coarse crimped wire wheel wide face	6,000
72753	4"x 5/8-11 thd knot wire cup brush	8,500
72754	5"x 5/8-11 thd crimp wire cup brush	8,500
72755	2-3/4"x 5/8-11 thd crimp wire cup brush	14,000
72756	6"x 5/8-11 thd knot wire cup brush	6,500
72757	2-3/4"x 5/8-11 thd knot wire cup brush	12,500
72758	6"x 5/8-11 thd knot wire wheel	9,000
72759	4"x 5/8-11 thd knot wire wheel	20,000
72760	4"x 5/8-11 thd stringer bead wire wheel	20,000
72780	2-3/4"x M-10x 1.25 crimped cup brush	14,000
72781	2-3/4"x M-10x 1.50 crimped cup brush	14,000
72782	2-3/4"x M-10x 1.25 knotted wire cup brush	12,500
72783	2-3/4"x M-10x 1.50 knotted wire cup brush	12,500
72784	4"x M-10x 1.25 knotted std. twisted wheel	20,000
72785	4"x M-10 x 1.5 TK wire wheel	20,000
72788	4"x 5/8-11 thd crimped wire wheel	15,000



72756



72780



72782



72785

ABRASIVES AND POWER BRUSHES

CRIMPED WIRE CUP BRUSHES



Cat. #	SIZE & THREAD	Max. RPM
72857	3" 1/2"-13NC	12, 500
72856	3" M14 x 2.0	12, 500
72856	3" 5/8"-11NC	12, 500
72855	3" M10 x 1.5	12, 000
72855	3" M10 x 1.25	12, 000
72887	4" 5/8"-11NC	6, 000
72860	5" 5/8"-11NC	6, 000

KNOT TWIST CUP BRUSHES

Cat. #	Size & Thread	Max. RPM
72865	3" M10 x 1.251	16, 000
72865	3" M10 x 1.5	16, 000
72866	3" 5/8"-11NC	16, 000
72866	3" M14 x 2.00	10, 000
72867	3" 1/2"-13NC	12, 500
72869	4" 5/8"-11NC	8, 500
72871	6" 5/8"-11NC	6, 000



BENCH GRINDER WIRE WHEELS

Cat. #	Diameter	Arbor	Style	Max. RPM
72841	6" x 5/8"	5/8"-11NC	knot twist	9, 000
72895	6" x 5/8"	1/2"	crimped	6, 000
72896	6" x 1"	1/2"	crimped	4, 000
72840	6" x 1"	1/2"	knot twist	9, 000
72897	8" x 1"	3/4" & 5/8"	crimped	4, 000

ADAPTERS FOR BENCH GRINDER WHEELS

72363	1/2"	72364	5/8"	72365	3/4"
72366	7/8"	72367	1"		



ABRASIVES AND POWER BRUSHES

CUP BRUSHES W/PROTECTIVE GUARD

- The guard acts as a shield that prevents wire, dust and any other kind of projection from reaching the user during work.
- The guard also makes the brush very user friendly in regards to handling the products.
- Powder Coated Hubs To Prevent Rusting.

CHECK IT OUT!!

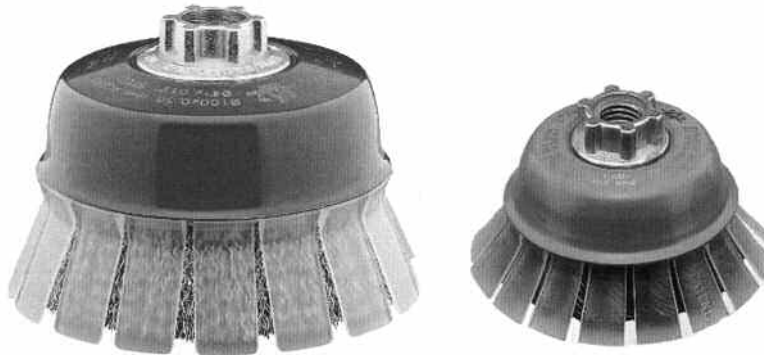

FORNEY	DESCRIPTION
72881	W/GUARD 3" Knot Cup M10x1.25/1.50 (CS)
72880	W/GUARD 3" Knot Cup 5/8"-11/M14 (CS)
72886	W/GUARD 3" Crimped Cup M10x1.25/1.50 (CS)
72885	W/GUARD 3" Crimped Cup 5/8"-11/M14 (CS)
72891	W/GUARD 3" Cable Crimped Cup M10x1.25/1.50 (CS)
72890	W/GUARD 3" Cable Crimped Cup 5/8"-11/M14 (CS)
72882	W/GUARD 4" Knot Cup 5/8"-11/M14 (CS)
72887	W/GUARD 4" Crimped Cup 5/8"-11/M14 (CS)
72892	W/GUARD 4" Cable Crimped Cup 5/8"-11/M14 (CS)

POWER BRUSHES

STRINGER BEAD BRUSH



Cat. #	SIZE & THREAD	Max. RPM
72845	4" M10 x 1.5	20,000
72847	4" 1/2 - 13 UNC	20,000
72845	4" X M10 x 1.25	20,000
72846	4" X 5/8 - 11 NC	20,000
72834	4" M10 x 1.5	20,000
72834	4" M10 x 1.25	18,000
72835	4" 5/8-11NC	20,000
72846	4" M14 x 2.0	18,000
72835	4" M14 x 2.0	20,000
72836	4" 1/2 - 13	20,000
72851	7" 5/8-11NC	9,000

CIRCULAR WIRE BRUSHES

Ideal for use around the shop or home. 1/4" shank.
Use with electric hand drills.



72820

Cat. #	Diameter	RPM
72821	3"	4,500
72822	3"	4,500
72818	1 1/2"	6,000
72819	2"	6,000
72820	2 1/2"	6,000



72257

72257 3" CRIMPED WIRE WHEEL

Special coating creates stiff aggressive cleaning action and extended brush life wire .014, RPM maximum 5,000. 3" diameter

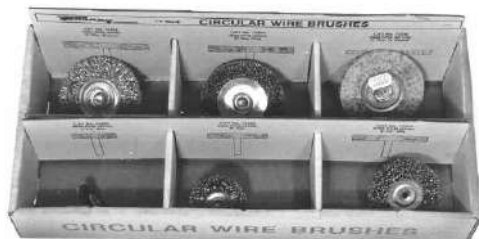

DISPLAY TRAY AND ASSORTMENT OF CIRCULAR WIRE BRUSHES

72246 contains 1 each (6 pc.)
82247 contains 5 each (30 pc.)

72818	72819	72820
72821	72822	72257

GRINDING WHEELS & BRUSHES



82275 WIRE CUP AND BRUSH DISPLAY

Ideal for the handyman or professional. Display tray contains 1 each of the following items.

72810	72811	72814
72827	72828	72829



72827



72810

CUP BRUSHES

Cat. #	Diameter	Arbor	Wire Size	Max. RPM
72827	1 1/2"	1/4"	.014	5,000
72828	2 1/2"	1/4"	.014	5,000
72829	2 1/2"	1/4"	.008	5,000
72857	3"	1/2"	13 x NC	13,000
72867	3"	1/2"	13 x NC	13,000
CRIMPED WIRE END BRUSH				
72810	3/4"	1/4"	.020	20,000
KNOT TWISTED END BRUSH				
72811	3/4"	1/4"	.020	20,000
CIRCULAR END BRUSH				
72814	1 1/2"	1/4"	.020	20,000

ALL PURPOSE 1/4" SHANK MOUNTED POINTS*

Quality aluminum oxide high speed mounted points for grinding, polishing and deburring.

82460 Display Tray of 12 Bulk Items (1 each)					
Carded	Bulk	Size	Carded	Bulk	Size
60025	72461	1" x 1 1/4"	60026	72462	1 1/4" x 1 1/4"
60027	72463	3/4" x 1 1/8"	60028	72464	7/8" x 2"
60029	72465	3/4" x 1 1/4"	60030	72466	1/4" x 3/4"
60031	72467	3/4" x 1"	60032	72468	1/4" x 3/4"
60033	72469	1" x 1"	60034	72470	1" x 1"
60035	72471	1" x 1 1/2"	60036	72472	1" x 1"

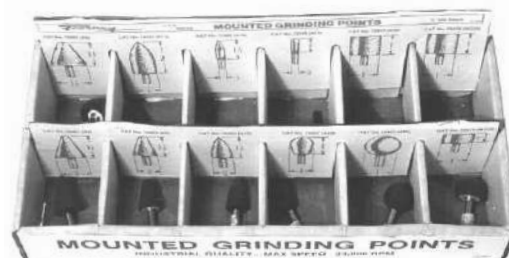

82457 DISPLAY TRAY ALL PURPOSE 1/4" SHANK MOUNTED GRINDING WHEELS

Rugged Dependable American Made Tools. 60 Grit Vitrified Aluminum Oxide. For Grinding Carbon, Alloy, and High Speed Steels as Well as Malleable and Wrought Iron, Bronzes & Other Hard Materials. For Use with 1/4" Drill. Especially Useful where Larger Wheels Won't Fit or Where Points Wear Too Quickly. Max. RPM 3,450 Contains 2 each of the following.



82451	1" x 1"	82452	1 1/2" x 1"
82453	2" x 1/4"	82454	2" x 1/2"
82455	2 1/2" x 1/4"	82456	2 1/2" x 1/2"

ROTARY FILES AND WOOD RASPS

ALL PURPOSE 1/4" SHANK ROTARY FILES AND WOOD RASPS

Tough, Rugged Tools Made from Special Tempered Steel. Files have Specially Hardened, Durable Cutting Edges for Long Life. Can be Used on Steels, Bronze, Fiberglass, Plastic and Many Other Materials. Wood Rasps Remove Material in Hard to Reach Areas. Ideal for Power Drills to Shape and Smooth Wood. Available in Bulk or Skin-Pack. RPM: 2,500.

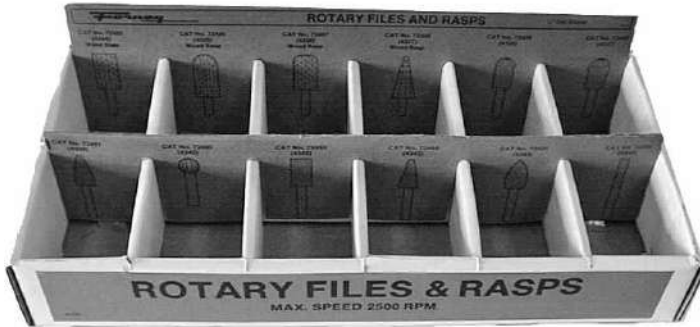

60024 SKIN-PACKED OPENING INVENTORY

Mounted Points, Rotary Files & Wood Rasps.
Includes free Plan-O-Gram 10511 and hooks. **2,500 RPM**

Carded	Bulk	Item	Carded	Bulk	Item
60065	72485	Rasp	60066	72486	Rasp
60067	72487	Rasp	60068	72488	Rasp
60069	72489	Rotary File	60070	72490	Rotary file
60071	72491	Rotary File	60072	72492	Rotary file
60073	72493	Rotary File	60074	72494	Rotary file
60075	72495	Rotary File	60076	72496	Rotary file

60119 Carbide Burs Opening Inventory (Carded)

Contains 1 each of the following items (14 items) plus a free Plan-O-Gram. **25,000 RPM**

Regular		Mini	
60120	1/4" (SA-1)	60127	3/8" (SG-3)
60121	3/8" (SA-3)	60135	1/8" (SA-42)
60122	1/4" (SD-1)	60136	1/8" (SF-42)
60123	3/8" (SD-3)	60137	1/8" (SH-41)
60124	1/4" (SF-1)	60138	1/8" (SM-42)
60125	3/8" (SF-3)	60139	1/4" (SE-51)
60126	1/4" (SG-1)	60140	1/8" (SA-43)

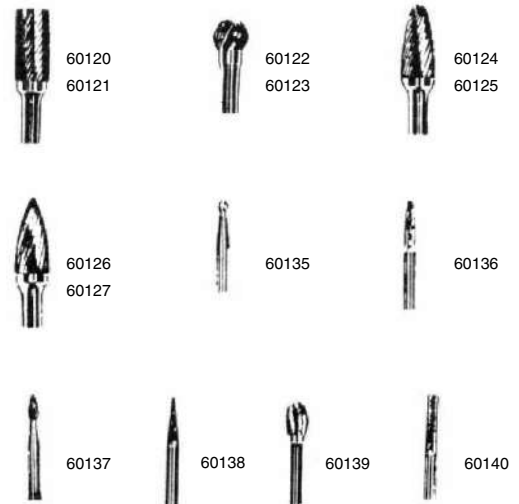

CARBIDE BURS

MICRO ABRASIVE CENTRE



MICRO-ABRASIVE CENTRE

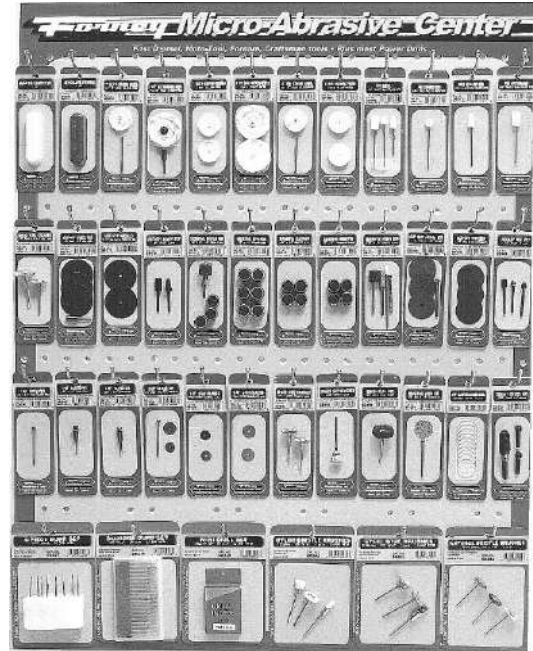

60200 OPENING INVENTORY (42 pc)
60197 OPENING INVENTORY (23 pc)

- High Speed Tools & Accessories; fit Dremel, Moto-Tool, Craftsman, Black & Decker, Wizard and Other Power Tools
- Attractively Skin-Packaged & Displayed on 24" x 30" User Friendly Plan-O-Gram
- Competitively priced for the Do-It-Yourselfer.

MICRO ABRASIVES

Cat.#	Description	Max Rpm	Cat.#	Description	Max Rpm
60201	1 oz. Red Jeweler's Rouge	30,000	60234	sanding discs set	30,000
60202	1 oz. White Buffing compound	30,000	60235	sanding discs 10-pcs.	30,000
60203	1" Buffing Wheel with Shaft	30,000	60236	Mini Pin Chuck set	30,000
60204	1-1/2" Cloth Buffing Wheel w/ shaft	30,000	60237	Burr set 8-pcs.	30,000
60205	1" Buffing wheel 2 pcs.	30,000	60238	Diamond Point set 20-pcs.	30,000
60206	1-1/2" Cloth Buffing Wheel 2-pc with shaft	30,000	60239	Mini Drill Bit set 20-pcs.	30,000
60207	1" Felt Polishing Wheel w/Shaft	30,000	60240	White nylon Impregnated	15,000
60208	1" Felt Polishing Wheel 2-pcs.	30,000		Bristle Brush set 3-pcs.	
60209	Felt Bob set-3 pcs.	30,000	60241	Wire Bristle Brush set 3-pcs.	15,000
60210	Felt Bob, Ball	30,000	60242	Bristle Brush set 3-pcs.	15,000
60211	Felt Bob, Bullet	30,000	60243•	8 PC Grinding & Polishing Kit	30,000
60212	Felt Bob, Cylinder	30,000	60244•	Sanding Sleeves 3/4" coarse 4 pc	30,000
60213	Brass Brush Set 2-pcs.	15,000	60245•	Sanding Sleeves 3/4" medium 4 pc	30,000
60214	Cut-Off Wheel set 4-pcs.	40,000	60246•	Sanding Sleeves 3/4" fine 4 pc	30,000
60215	Cut-Off wheel 3-pcs.	40,000	60247•	Sanding Drum 3/4"	30,000
60216	Rotary Rasp set	30,000	60248•	Sanding Drum 3/4" Kit 5 pc	30,000
60217	Sanding drum 1/2" Kit	30,000	60249•	Diamond Wheel 3/4" 4 pc	30,000
60218	Sanding Sleeves 1/2" Fine 6-pcs.	30,000	60250•	Diamond Wheel 3/4" 2 pc & Mandrel	30,000
60219	Sanding Sleeves 1/2" Med. 6-pcs.	30,000	60251•	Steel Wire Wheel 1" 2 pc	15,000
60220	Sanding Sleeves 1/2" Coarse 6-pcs.	30,000	60252•	Satin Finish Buff Wheel 1" 2 pc	30,000
60221	Mounted Point set 3-pcs. 1/2" x 1/2" Cylinder, 1/4" x 1/2" Ball, 1/8" Tree pt)	30,000	60253•	Felt Wheel 3 row 3/32" Shank 7/8" 2 pc	30,000
60222	Cut-Off Wheel set w/Mandrel	30,000	60254•	Rotary File Cutter 2 pc	30,000
60223	Cut-Off Wheels 3-pcs..	30,000	60255•	Mini Burr- Flame 2 pc	30,000
60224	Rotary File Cutter set 3-pcs. (cylinder, ball, flame)	30,000	60256•	Mini Burr- Cone 2 pc	30,000
60225	Mandrel 1/8" Shank x 1/16" Hole	30,000	60257•	Mini Burr- Inverted Cone 2 pc	30,000
60226	Mandrel 1/8" Shank x Long screw	30,000	60258•	Mini Burr- Wheel 2 pc	30,000
60227	Mandrel 1/8" Shank x Short screw	30,000	60259•	Mini Burr- Ball 2 pc	30,000
60228	Saw Blade set (3-pcs.) 60225-60229-60330	30,000	60260•	Chain saw Sharp Stone 5/32" 2 pc gray	30,000
60229	Saw Blade Small 1/2" 2-pcs.	30,000	60261•	Chain saw Sharp Stone 3/16" 2 pc brown	30,000
60230	Saw Blade Large 5/8" 2-pcs.	30,000	60262•	Chain saw Sharp Stone 7/32" 2 pc pink	30,000
60231	Brass Circular Brush 2-pcs.	15,000	60263•	Chain saw Sharpening Stone Set 3 pc	30,000
60232	Brass Cup Brush 2-pcs.	15,000	60264•	Mini Chuck Keyless	30,000
60233	Scuff-Buff pad with Mandrel	30,000	60265•	Micro Chuck	30,000

SAFETY PRODUCTS



55663 SUPER SLIM ECONOMY HELMET

This light, durable, black nylon helmet features an extended lower bib which deflects spatter and improves rigidity. Comes with a 2" x 4¼" #10 shade and clear plastic cover lens. Complete with ratchet-adjustable headgear.



55666 "THE BANDIT" BLACK PVC

This lightweight, tough durable welding helmet has a 2" x 4¼" lift front making it a good choice for the do-it-yourselfer. Helmet is complete with ratchet headgear 55667. Comes with a #10 shade lens.



55673 BLACK BANDIT II NYLON WELDING HELMET

Lightweight, this tough helmet has the added convenience of a large 4½" x 5¼" viewing area. Complete with ratchet headgear 55667, #10 shade lens and clear protective cover lens.

55801	Ratchet Headgear for 55671/55686
55797	Headgear Repair Kit for 55801
55807	Lens Retainer Spring - 4½" x 5¼"

SAFETY PRODUCTS

AUTO-DARKENING WELDING HELMETS 4200 SERIES



4200
Black, no painting



4220
Red with Racing Car
and Flags



4219
Black with Skull,
Flames and Lion

INSTA-SHADE WELDING HELMETS

FEATURES:

- Solar power cell design, no battery replacement required
- Full automatic power ON/OFF
- Can be used for MIG/MAG, TIG and ARC welding
- Two switches to adjust the Delay Time and Sensitivity
- Very light design, only 425g.

SPECIFICATIONS:

- Viewing Area: 98 mm x 44 mm / 3.86" x 1.76"
- Cartridge Size: 110 mm x 90 mm / 4.33" x 3.54"
- Light State: Shade DIN 4 - Dark State: Shade DIN 9-13
- Switching Time Light to Dark: 0.00004 sec.
- Helmet Material: High Impact Polyamide Nylon

REPLACEMENT PARTS 4200 SERIES

9907	Front lens
9908	Inside lens
9909	Replacement auto-filter
9910	Front cover lens
9911	Inside cover lens
9949	Replacement headgear

9929 Replacement headgear
(1800 Series)

SAFETY PRODUCTS

AUTO-DARKENING WELDING HELMETS PRO SERIES 4260



4260
Black, no painting



6218
Grey Ghost



6320
Silver Skull



4263
Black with Skull,
Flames and Lion



4264
Red with Racing
Car and Flags



4265
Canadian Hockey

FEATURES:

- Solar power cell design with replaceable batteries
- Full automatic power ON/OFF
- Can be used for MIG/MAG, TIG and ARC welding and Plasma cutting
- 4 sensor design ensures higher sensitivity
- Grinding feature on Shade 4, Plasma cutting on shade 5-9 and welding on shade 9-13
- Knob to adjust the delay time and sensitivity
- Cheater Lens Compatible
- Hard hat adaptor (Optional)
- Battery indicator and testing
- Power off delay 10 mins., the filter keeps alive for 10 mins in dark environment before it goes to sleep
- Very light design, only 435g.

SPECIFICATIONS:

- Viewing Area: 96 mm x 52.5 mm / 3.78" x 2.5"
- Cartridge Size: 110 mm x 90 mm x 9 mm / 4.33" x 3.54" x 0.35"
- Light State: Shade DIN 4 - Dark State: Shade DIN 5-9/9-13
- Switching Time Light to Dark: 0.00004 sec.
- Helmet Material: High Impact Polyamide Nylon

SAFETY PRODUCTS



55676

55676 PLASTIC HEADGEAR

For helmets 55791 and 55793. Has pin adjustment for crown strap & includes sweatband. Fits Jackson/Morsafe



55711

55711 PLASTIC HEADGEAR

RATCHET ADJUSTMENT

Strong non-warping, self-extinguishing plastic features free floating suspension to eliminate pressure on head. Fits Fiber Metal helmets



55801

55801 PLASTIC HEADGEAR

RATCHET ADJUSTMENT

Made with overhead crown straps, pivots attached to tabs extending from the headband connect the shell to the headgear, eliminating pressure to the wearer's temples. Fits Forney helmets 55663, 55671, 55672 & 55686.



55667

55667 Headgear with ratchet adjustment for 55666 and 55673 Welding Helmets.



55828

HARDHAT, BALL-CAP STYLE

Made of High-Density Polyethylene, with ratchet headgear. Complies with ANSI Z-89 Standards. White or Yellow



55829

55828 Hardhat, White

55829 Hardhat, Yellow

SAFETY PRODUCTS



HELMET LENS - 4 1/2" X 5 1/4"

57029	Shade 5	57050	Shade 8
57051	Shade 9	57052	Shade 10
57053	Shade 11	57054	Shade 12
57055	Clear Plastic	57056	Clear Glass
57070	Gold Filter Shade 9		
57071	Gold Filter Shade 10		



WELDING GOGGLE LENSES

For cutting and gas welding operations. (Sold in pairs only)

56900	Shade # 5 - 50 mm Round, Glass
56901	50 mm Round, Clear Plastic



MAGNA WELD MAGNIFYING LENS

Can be used with most helmets and some goggles. May allow user to weld with or without glasses.

57101	Magna Lens F1.00	57103	Magna Lens F1.50
57105	Magna Lens F2.00	57107	Magna Lens F2.50

WELDING LENSES - 2" x 4 1/4"

Darker shades are for intense welding at higher amperage or in sunlight. Lighter shades are for simple welding and indoors. Forney high quality clear plastic cover lenses offer superior protection from dust, weld spatter and impact.

The Lens Shade Selection Chart is a general guideline. Begin with a shade too dark to clearly see the weld zone. Then step down to a shade which clearly shows the weld zone. **Do not go below the chart recommendations. Use shade 5 lenses only for gas welding.** Don't take chances! Consult a physician if you are not certain about how to properly protect your eyes during a welding operation.

For prolonged periods of welding or to see true flame arc and puddle color we recommend our gold coated plastic lenses (see below).

In addition to full UV/IR protection, the gold coating reflects 90% of radiated heat for cooler operation and less eye fatigue. No Forney lenses are suitable for solar eclipse viewing.

Forney* Lens Shade Selection Chart

Lens Shade	Amps Arc Welding	Amps Mig Welding	Amps Plasma Cutting	Capacity Oxy-Acet.
5	-	-	-	1/2" Welding 8" Cutting
8	15 to 20	-	5 to 20	
9	20 to 40	40 to 80	10 to 15	
10	40 to 80	80 to 150	15 to 30	
11	80 to 175	150 to 275	30 to 150	
12	175 to 300	275 to 450	150 to 250	



57005	Shade 5	57008	Shade 8
57009	Shade 9	57010	Shade 10
57011	Shade 11	57012	Shade 12
56800	Clear Plastic	56801	Clear Glass

SAFETY PRODUCTS / GOGGLES



55301 "CYCLOPS" WELDING GOGGLE

Soft one-piece opaque frames, with the lens holder as an integral part of the frame. Designed to follow the contour of the face and fit over prescription glasses. Elastic head band included. Takes a 2" x 4¼" lens



55304 SOFT VINYL FLIP-UP GOGGLES

Fit comfortably over regular eyeglasses. Cover lens fits in flip up. Shade #5 50 mm. lenses



55311 EYE CUP GOGGLES

Equipped with 50 mm round #5 shade lens and cover lens. Very compact when folded, excellent for pocket storage.



55320 LIFT-FRONT SOFT VINYL GOGGLES

Six air vents for cooling prevent fogging. Conforms comfortably to face. Allows ample room for eyeglasses. Cover lens fits under flip up. #5 Shade 2" x 4¼ lens



55305 SAFETY GOGGLES

Forney offers goggles in both economy and deluxe models with clear and green lenses. Ideal for working in the shop. Great for some outdoor sports activities as well as yard chores such as trimming plants (WEED WACKERS ETC).



55305 CHEMICAL GOGGLES

55310 CLEAR PLASTIC GOGGLES

SAFETY PRODUCTS

GRINDING SHIELD WITH FACE COVER LENS

Light weight for maximum comfort, made of tough poly-type plastic. Sturdy non-warp construction provides greater comfort, ventilation and safety. Two styles to choose from. Both take the same replacement shield.



58600
58605

58600	Complete grinding shield with clear lens
58601	Headgear only 58600
58602	Clear replacement lens for 58600
58603	Green replacement lens for 58604/58606
58604	Complete grinding shield with green lens
58605	"Ratchet" grinding shield with clear lens
58606	"Ratchet" grinding shield with green lens
58608	Ratchet headgear for 58605

DP4 GRINDING SHIELD WITH FLIP-DOWN WINDOW

Unique design features a clear window for grinding and a #5 shaded flip-down window for cutting and brazing or a #8 shaded flip-down window for Gas Tungsten Arc Welding (GTAW) or low-amperage Plasma Arc Cutting and Welding.



58615
58616

58615	Clear window DP4 with #5 flip-down window
58616	Clear window DP4 with #8 flip-down window
58620	Replacement clear shield
58621	#5 replacement flip-down shield
58622	#8 replacement flip-down shield
58624	Replacement ratchet headgear

Meets ANSI Z87.1 standards

SAFETY PRODUCTS

**SAFETY GLASSES THAT ARE STYLISH, DURABLE,
LIGHT, FLEXIBLE FOR AN EASY FIT**

	1 - 55287	Safety Glasses Chroma (Clear)
	2 - 55288	Safety Glasses Chroma (Mirrored)
	3 - 55285	Safety Glasses #5 (Green Lens)
	4 - 55294	Visitor Glasses (Gray Lens)
	5 - 55295	Visitor Glasses (Clear Lens)
	6 - 55289	Safety Glasses (Gold Lens)
	7 - 55339	Hawk Safety Glasses (Clear)
	8 - 55340	Hawk Safety Glasses (Mirrored)
	9 - 55335	Fusion (Clear)
	10 - 55336	Fusion (Mirrored)
	11 - 55329	StarLite (Amber/Yellow)
	12 - 55330	StarLite (Mocha/Brown)
	13 - 55338	StarLite (Mirrored)
	14 - 55337	StarLite (Clear)

SAFETY GLASSES



55275 SAFETY GLASSES DISPLAY

Contains one each of the following:

55294, 55295, 55329, 55330, 55335, 55336,
55337, 55338, 55339, 55340.



Assorted styles with clear, mirrored, amber, mocha and other optional lenses.

55275 Display includes plan-o-gram and metal hooks.

SAFETY PRODUCTS

55905 MULTI-PURPOSE RESPIRATOR

General Purpose. Protects against Dust, Paints including Enamel, Lacquers, Pesticides and Organic Vapors. For Homemakers, Gardeners, Painters, Auto Body Workers.



55905

55910 COMPLETE ORGANIC VAPOR REPLACEMENT CARTRIDGE FOR 55905 (PAIR)

55915 PRE-FILTER FOR 55905

(6 pack with 2 retainers)



55910

55915

55975 DISPOSABLE RESPIRATORS (2 per package) FOR DUSTS & MISTS (OSHA APPROVED)

For General Use. Protection against Paints, Sprays, Dust, etc.



55975

DUST MASKS

55973 50 per package

A Double Absorbent Filter with Comfortable Custom Nose Piece. Ideal for Sawing, Sanding & Shaping Wood and for other Dusty Work Areas. For Paint & Other Fumes-see 55975 or, especially, 55905 above.

55871 - 5 per package

55876 - 6 packages of 50

55877 - 12 packages of 50

55878 - Dust & mist respirator box of 20

55879 - Dust & mist respirator package of 5



55871

55980 TRU-FIT HEARING PROTECTION (YELLOW)

Lightweight Earmuff. Provides excellent ear protection and comfort. Designed for common levels of industrial noise Ear Cups Adjustable. N.R.R. Overhead 21.*



55980

55984 DELUXE TRUE-FIT HEARING PROTECTION (RED)

Ear Muffs provide maximum protection from most noise. Quick, easy removal for brief communication in very loud conditions. Headband adjustable and padded for added comfort. N.R.R. Overhead 22.*



55984

55993 (6 PR) SAFE-EAR SOFT FOAM INSERTS

Easily compressed, they hold a thin shape until inserted. Then they expand to give excellent sound protection. Disposable.

N.R.R. 25 dba.*

55863 (200/BOX) DISPOSABLE EAR PLUGS

WELDING GLOVES

55193 DEERSKIN TIG WELDER'S GLOVE
Men's X-Large

Tig welder's glove, deersplit, stiff split cuff.



55193

55194 SHEEPSKIN TIG WELDER'S GLOVE
Men's X-Large

Tig welder's glove, sheepskin, stiff cow split cuff.



55194

55196 PREMIUM WELDER'S GLOVE
Men's Small – Medium

55197 PREMIUM WELDER'S GLOVE
Men's Large – X-Large

Welders gauntlet, Kevlar™ stitched throughout, welted last finger, fully lined fleece hand, rivet at inside cuff.



55196
55197

55198 UNLINED WELDER'S GLOVE

Cowhide palm, cowsplit back, 4" cuff.



55198

55202 LEATHER WELDING MITTS

Ideal for working in a cold environment.



55202

55200 LINED LEATHER WELDING GLOVES
Men's Large

Lined interior for insulation against heat. Heavy-duty, long lasting for maximum protection. 13-1/2" long.



55200

55203 DELUXE LINED ALL LEATHER WELDING GLOVES

Men's Large

Top of the line. Fully lined interior for additional insulation against heat. Excellent protection, comfort and durability. 13-1/2" long.



55203

55259 GAUNTLET PVC COATED GLOVES
Men's Large

For Use with Liquids. Resist Snags & Cutting.



55259

BULK AIR FITTINGS

***NEW!* BULK AIR FITTINGS BY FORNEY**

Bulk Plugs and Couplers in Tilt Out Bins
Catalog #75210

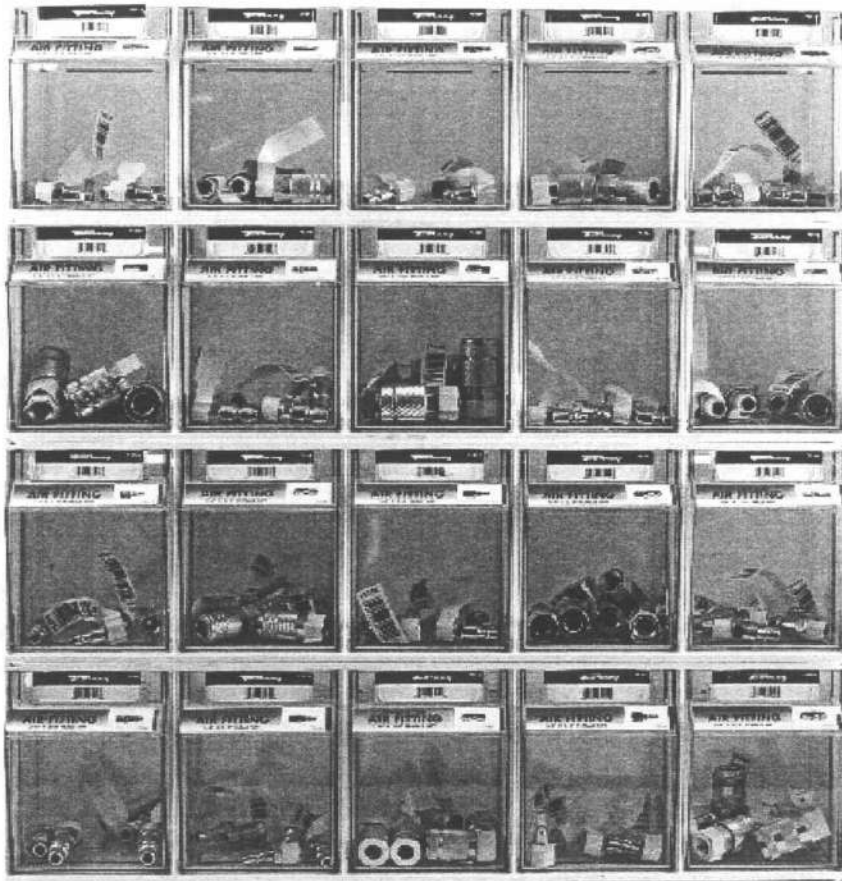

**HORIZONTAL 5 COMPARTMENT
BIN TRAY ONLY**
Cat. No. # 10254



HEAD OFFICE: Regina, Saskatchewan • Telephone: 1-800-667-8161 Fax: 1-800-404-3551
EASTERN WAREHOUSE: Hawkesbury Ontario • Telephone: 1-888-811-0889 Fax: 1-888-811-1120

BULK AIR FITTINGS

T-Style Tru-Flate/Parker Interchange Series – 1/4" Basic Size

Part No.	Description
75215	1/4" male NPT plug
75220	1/4" female NPT plug
75222	1/4" male NPT coupler



75215



75222



75220

P-Style Tru-Flate/Parker Interchange Series – 3/8" Basic Size

Part No.	Description
75224	1/4" male NPT plug
75226	3/8" female NPT coupler
75228	3/8" male NPT plug
75230	1/4" female NPT coupler



75224



75226



75228



75230

M-Style Industrial Interchange Series – 1/4" Basic Size

Part No.	Description
75234	1/4" male NPT plug
75236	1/4" male NPT coupler
75238	1/4" female NPT plug
75240	1/4" female NPT coupler
75242	3/8" male NPT plug
75244	3/8" female NPT coupler



75234



75236



75238



75240



75242



75244

H-Style Industrial Interchange Series – 3/8" Basic Size

Part No.	Description
75246	1/4" male NPT plug
75247	3/8" female NPT coupler
75248	3/8" male NPT plug



75246



75247



75248

A-Style Aro "210" Style Series – 1/4" Basic Size

Part No.	Description
75250	1/4" male NPT plug
75252	1/4" female NPT coupler
75254	1/4" female NPT plug



75250

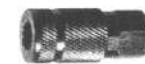

75252



75254

AMT Style 3-Way Coupler – 1/4" Basic Size

Part No.	Description
75260	1/4" female NPT coupler



75260

PACKAGED AIR FITTINGS & ACCESSORIES

COUPLERS / PLUGS

Provides compressed air for tools/accessories in homes and shops. The quick disconnect coupler and matching nipple system provides smooth, fast interchanging of tools from the same air source, extending the length of an air system.

TRU-FLATE DESIGN

(Color Code: Yellow)

Tru-Flate Plugs have an extremely short pilot—the widest metal section between the ball groove and the pilot. This and wider sealing surfaces on the end of the plug results in tighter sealing and longer life. True-Flate Couplers allow more air flow at pressure drops. The protective collar also guards against accidental disconnect.



75519• COUPLER/PLUG SET

1/4" Female NPT Coupler

1/4" Male NPT Plug

1/4" PLUGS

1/4" COUPLERS

75590 1/4" NPT Male



75309• 1/4" NPT Male



75592 1/4" NPT Female



75315• 1/4" NPT Female



75470• 1/4" Male



75478• 1/4" NPT Female



75398 1/4" x 3/8" NPT Female



75400• 1/4" x 1/4" ID Hose Barb



75399 1/4" x 3/8" NPT Male



75401• 1/4" x 3/8" Female NPT



75402• 1/4" x 3/8" Male NPT



3/8" PLUGS

3/8" COUPLERS

75475• 1/4" NPT Male



75320• 3/8" NPT Female



75306• 3/8" NPT Male



75484• 3/8" NPT Male



75476• 3/8" NPT Female



75485• 1/4" NPT Female



75322 3/8" x 1/4" NPT Female



PACKAGED AIR FITTINGS & ACCESSORIES

INDUSTRIAL/MILTON DESIGN

(Color Code: Red)

The 3/16" pilot and flat "V"-shaped ball groove plug design is considered the standard because it has been adapted by most coupler manufacturers. Couplers are available in standard and push-to-connect style sleeves. Push-to-connect styles are for permanent wall mounted connections.



75305• COUPLER/PLUG SET

1/4" Female NPT Coupler
1/4" Male NPT Plug

1/4" PLUGS

75600

1/4" NPT Male



75602

1/4" NPT Female



75471

3/8" NPT Male



75472

1/4" NPT Male



1/4" COUPLERS

75316

1/4" x 1/4" NPT Male



75317

1/4" x 1/4" NPT Female



75479

1/4" x 3/8" NPT Female



75480

1/4" x 1/4" Hose Barb



1/4" PUSH-TO-CONNECT STYLE SPRING CLIP TYPE LOCK MECHANISM

For wall mounted connections



75520•

1/4" Female NPT

75521•

1/4" Male NPT



3/8" PLUGS

75307

3/8" NPT Male



75474

3/8" NPT Female



75323

1/4" NPT x 3/8" Male



3/8" COUPLER

75483

3/8" NPT Male



75321

3/8" NPT Female



75324

3/8" x 1/4" Female NPT



PACKAGED AIR FITTINGS & ACCESSORIES

Aro is easily identified by a 5/16" pilot and nearly round ball groove. Couplers are available in standard and push-to-connect style sleeves.

ARO DESIGN (Color Code: Green)



75522• COUPLER/PLUG SET
1/4" Female NPT Coupler 1/4"
Male NPT Plug

1/4" PLUGS

1/4" COUPLERS

75303 1/4" NPT Male



75482 1/4" NPT Male

75473 1/4" NPT Female



75318 1/4" NPT Female

LINCOLN DESIGN (Color Code: Blue)



75523• COUPLER/PLUG SET
1/4" Female NPT Coupler 1/4"
Male NPT Plug

1/4" PLUGS

1/4" COUPLERS

75304 1/4" NPT Male



75525 1/4" NPT Male

75524 1/4" NPT
Female



75319 1/4" NPT Female

High Quality Universal Couplers fit the three most popular air line plugs. Can be used with True-Flate, Industrial Milton & Aro Design 1/4" Plugs. Push-to-connect style makes coupling quick & easy.

UNIVERSAL DESIGN (Color Code: Gold, Red & Green)



75526
1/4" COUPLER NPT Male

75527
1/4" COUPLER NPT Female

PACKAGED AIR FITTINGS & ACCESSORIES



AIR HOSE SPLICERS

- 75355•.....5/16" Hose Mender
- 75357•.....3/8" x 3/8" Hose Barb
- 75361•.....1/4" x 1/4" Hose Barb

Used to repair damaged hose or to extend sections for greater length.



FEMALE HOSE ENDS

- 75362•.....1/4" NPT x 1/4" Hose Barb
- 75358•.....1/4" NPT x 3/8" Hose Barb



MALE HOSE ENDS

- 75353•..... 5/16" ID Male Hose End 1/4" NPT
- 75354•..... Male Hose End 3/8" ID x 3/8" NPT
- 75360•.....1/4" NPT x 1/4" Hose Barb
- 75359•.....1/4" NPT x 3/8" Hose Barb



75447 REDUCER ADAPTER

3/8" NPT Female à 1/4" NPT Male



75448 BRASS COUPLING

1/4" NPT Male x 1/4" NPT Male (non-swivel style)

75449 BRASS COUPLING

3/8" NPT Male x 3/8" NPT Male (brass coupling)



75385 COUPLER TEST BAR

Tru-Flate, Industrial/Milton, Aro and Lincoln

Quickly and Accurately Identify the Proper 1/4" series Plug for a Coupler. Metal Bar has Each of Four Basic Design Plugs. Each Design Name is Stamped on Bar.

PACKAGED AIR FITTINGS & ACCESSORIES

75530• FEMALE HOSE END*

3/8" Hose Barb x 3/8" Female NPT



75530



75531

75531• FEMALE SWIVEL HOSE END*

1/4" Hose Barb x 1/4" Female NPT

75532• BRASS FEMALE COUPLING

1/4" Female NPT x 1/4" Female NPT



75532



75533

75533• BRASS REDUCER

3/8" Male NPT x 1/4" Male NPT

75534• BRASS BUSHING 1/8"

1/4" Male NPT x 1/8" Female NPT



75534



75535

75535• BRASS BUSHING

1/4" Female NPT x 3/8" Male NPT

75536• BRASS BUSHING

3/8" Female NPT x 1/2" Male NPT



75536



75537

75537• BRASS BALL END ADAPTER

1/4" Male x 1/4" Male NPT

AIRLINE SWIVEL FITTINGS

Eliminates Kinked & Twisted Airline Hose by Swiveling a Full 360 degrees. Use on Air Lines, Tools and Compressor Connections for Increased Flexibility and Convenience.

75538• 1/4" AIRLINE SWIVEL* BARB TYPE

1/4" Male NPT x 1/4" Hose Barb. Connect to Hose with a Clamp or Crimp on Ferrule.



75538

75539• 3/8" AIRLINE SWIVEL* BARB TYPE

1/4" Male NPT x 3/8" Hose Barb. Connect to Hose with a Clamp or Crimp on Ferrule.



75539

75540• AIRLINE SWIVEL

1/4" Female NPT x 1/4" Male NPT. Perfect for Compressor to Airline Connection.



75540

AIR FITTINGS AND ACCESSORIES

BLOW GUNS



75330



75331



75332



75334

75333



75494



75529



75329

11000

BLOW GUNS

NOTE: All Forney Blow Guns conform to OSHA standards, including noise level and output pressure with an inlet pressure of 150 psi. All constructed from heavy die casting & are 1/4" female NPT. Always wear safety glasses to avoid eye damage.

75330• SYPHON SPRAY & BLOW GUN COMBO

Has barbed inlet that fits 1/4" ID hose. Spray liquids to clean parts, apply protective coatings or to clean engines. (Must be used on regulated 30 psi airline).

75331• SAFETY BLOW GUN

Pressure reduction to 30 psi. Vented nozzle relieves pressure if nozzle should become plugged or obstructed.

75332• SAFETY BLOW GUN

Small lightweight unit with vented nozzle.

75333 ADJUSTABLE POCKET BLOW GUN

75334 ADJUSTABLE POCKET BLOW GUN

Adjustable Pocket Blow Guns. Quick turn adjusts from low to full volume air flow. Great for Home or Shop use. Handy Pocket Clip. Must be used on regulated 30 psi airline. Maximum recommended pressure 150 PSI.

INDUSTRIAL/MILTON DESIGN 1/4" Plug

75494 BLOW GUN WITH RUBBER TIP

For blowing out tubing lines & small orifices. Excellent for cleaning carburetors, etc. (Replacement tips available.)

75529 DELUXE BLOW GUN KIT

All purpose blow gun with attachments for blowing sawdust, grass clippings, drying surfaces or inflating balls, and air mattresses.

11000 ENGINE CLEANING GUN

Clean motors, farm equipment, poultry houses, shop machinery, floors, walls, tiles, etc.. Operating pressure range is 40 to 150 PSI. Solvent is drawn from the container and mixed with the compressed air. Dissolves stubborn dirt, grease, mud, etc. Weight - 1/2 pound.

75329 PISTOL GRIP SPRAY CLEANING GUN

AIR FITTINGS AND ACCESSORIES



11049



11050



11051

11049 AIR FILTER 5 Micron Filter with 1/4" NPT.

11050 PRECISION LUBRICATOR 1/4" NPT
2 oz. bowl with guard. **150 PSI Maximum Working Pressure**

11051 REGULATOR AND GAUGE
Regulated pressure range is from 0 to 125 PSI
1/4" NPT standard female fittings.
Maximum working pressure of 150 PSI.

PRESSURE GAUGE

75565	1/8" NPT, 160 PSI	11028	1/4" NPT, 100 PSI
11027	1/4" NPT, 160 PSI	11029	1/4" NPT, 200 PSI
75554	1/4" NPT, 160 PSI		



11029



11018

75548 1/4" BRASS CHECK VALVE
For air compressors.



75549

11018 3/8" BRASS CHECK VALVE
For air compressors.

75549• TANK MANIFOLD FOR AIR COMPRESSORS
TANK MOUNT 1/2" NPT SWITCH MOUNT 1/4" NPT GAUGE & OUTLET 1/4" NPT. Allows the user to attach a manifold to the tank, a pressure switch and a safety valve to the manifold, plus a port for a pressure gauge.



75550

75550• TANK MANIFOLD FOR CARRY TANKS
TANK MOUNT 1/2" NPT/GAUGE & NPT OUTLETS 1/4" NPT
Same as 75549 above without the pressure switch outlet.

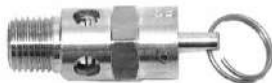

75551

BRASS SAFETY VALVES (POP OFF TYPE)

75551 •.....1/4" NPT 150 PSI

75552 •..... 1/4" NPT 125 PSI



11047

11047 SAFETY VALVE
Set at 140 PSI, 1/4" NPT Non Adjustable.



75365
75366



75363
75364

75363• BRASS TEE1/4" NPT 150 PSI

75364• BRASS TEE3/8" NPT 150 PSI

BRASS CROSS (4-WAY)

75365•.....1/4" NPT 150 PSI

75366•.....3/8" NPT 125 PSI

AIR FITTINGS AND ACCESSORIES



75555
75556

PRESSURE SWITCH

Automatically maintains tank pressure on small compressors.

75555	95 - 125 PSI	75556	115 - 150 PSI
--------------	--------------	--------------	---------------



75558



75561

11042 BLEEDER VALVE

For 75555-75556

75558 3-in-1 MANIFOLD

(3) 1/4" NPT OUTLETS & (1) 1/4" NPT INLET

To supply three air tools with one source. Air hose end or fixed bench outlet. The perfect shop bench accessory.



75560



75562

BRASS MANIFOLDS

75560• 3-IN-ONE MANIFOLD (FLAT) 1/4" NPT 125 PSI

75561• SWIVEL 1/4" MALE NPT x 1/4" FEMALE NPT 125 PSI

75562• UNIVERSAL SWIVEL 1/4" MALE NPT x 1/4" FEMALE NPT 125 PSI



A



B

75541 AIR HOSE REPAIR KIT

For Repairing 1/4" I.D. Hoses.

Includes items A, B, C, D.



C



D



75542

75542 AIR/WATER ADAPTER

For filling Tires with liquids. Connects standard tractor valve to 3/4" Garden Hose Bibb. Push Button Bleeder Valve Releases trapped air. Clamps Fit Standard Air/Water Valves. New Fast Flow Valves, Large Bore Valves and Extensions or Standard Stem Valves.



75543

75543 TANK VALVE

1/8" MALE NPT For Pressure Tanks and Compressors, Air Lifts etc. requiring a dependable Air Valve. Max. Working Pressure 200 PSI.



75545

75367• 1/4" NPT

75368• 1/8" NPT

DRAIN COCK FOR COMPRESSOR TANK DRAIN



75367

75545 MINI FILTER - 1/4" NPT 32 CFM At 100 PSI 5 MICRON FILTER ELEMENT

Removes Airborne Contaminants (liquid, oil, water or dirt) from Air Lines.

AIR FITTINGS AND ACCESSORIES



75336 / 75337
SAFETY EXTENSION BLOWGUN
WITH RUBBER TIP & SAFETY NOZZLE

These multi-function, long reach blowguns come with both a safety nozzle and rubber tip. End of blowgun is bent for hard to reach areas.

75336	2' Extension Blowgun
75337	4' Extension Blowgun



75547



75546

75546 MINI REGULATOR
 1/4" NPT 16 CFM AT 300 PSI 2-1/8" NPT GAUGE
 PORTS 5 TO 125 PSI AT OUTLET

75547 MINI LUBRICATOR
 1/4" NPT 12 CFM 150 PSI 1 OZ. BOWL
 (Bowl not sold separately)



75340

75340 DIRECT LINE AIR CHUCK
 1/4" Female NPT with Built in Shut Off.
 (Cannot be used with inflator gauges.)



75349

75349 DUAL FOOT AIR CHUCK
 1/4" NPT for Servicing Air Valves on Trucks, Buses and RV's
 with Dual Wheels. Complete with Hang-up Hole.



75489

75489 AIR CHUCK WITH 1/4" ID HOSE BARB



75487

75487 SNAP-ON CHUCK CLIP
 1/4" Female NPT. Built in Shut-Off Valve.



75488

75488 SNAP-ON CHUCK CLIP
 Fits Forney 75487 and 75340.

AIR CHUCKS, MINI REGULATORS & MINI LUBRICATORS

AIR FITTINGS AND ACCESSORIES

TIRE AND VALVE PARTS



75381



75380

75381 PLASTIC DOME TYPE TIRE VALVE CAP

75380• SCREWDRIVER TIRE VALVE CAP



75403

TUBELESS TIRE VALVE (PAIR)

75403.....2" L x .625 rim hole

75513.....1-1/4" L x .625 rim hole

75514.....1-1/4" L x .453 rim hole

75516.....2" L x .453 rim hole



75507

75507 TIRE REPAIR KIT



75509

75509 HEAVY-DUTY RADIAL TIRE REPAIR KIT



75511



75512

75511 SHORT TIRE VALVE CORE

75512 TIRE VALVE EXTENSION



75370

75370 FOUR-WAY TIRE VALVE REPAIR TOOL

Removes Intact or Broken Valve Cores. Repairs Cap and Core Threads.

AIR FITTINGS AND ACCESSORIES



PVC AIR HOSE IN SELECTED LENGTHS & SIZES

General purpose hose. High quality, economical, lightweight and very flexible. 0-150 range. 2:1 working pressure safety factor. Resists grease, oil, abrasion & weathering. 300 PSI. burst strength. Ideal for Service Stations, Garages, Farm use etc..

Temperature Range 15° F to 150° F
 Working Pressure @ 122° F 150 PSI
 Working Pressure @ 70° F 250 PSI

Cat. #	Dimensions	Male End
11052	1/4" x 6'	1/4"
75406	1/4" x 25'	1/4"
75407	1/4" x 50'	1/4"
75410	3/8" x 25'	1/4"
75411	3/8" x 50'	1/4"
75415	3/8" x 100'	1/4"
75420	1/2" x 25'	3/8"
75421	1/2" x 50'	3/8"

75412	Bulk 1/4" hose by the foot
75413	Bulk 3/8" hose by the foot



RECOIL AIR HOSE

Manufactured of tough abrasive resistant nylon, temp -20° to 175° F. Extends to 25 times its stored length. Coils up when not in use. Bright yellow with swivel assembly. Great for garages, home shops & service stations.



# Cat.	Dimension	Male End
75417	1/4" x 12 1/2'	1/4"
75418	1/4" x 25'	1/4"
11670	1/4" x 50'	1/4"
75425	3/8" x 25'	3/8"
11675	3/8" x 50'	3/8"



POLYURETHANE - RECOIL AIR - HOSE

11681	1/4" X 25'	1/4"
11685	3/8" X 25'	3/8"

BULK AIR HOSE & RECOIL AIR HOSE

AIR FITTINGS AND ACCESSORIES

75347 DUAL FOOT SERVICE GAUGE

10-150 LBS.

Designed for Heavy Duty use. Accurate and Dependable. Has 6" Extension to Reach the Inner and Outer Wheels of Duals. 2 Sided Nylon Bar Calibrated 20-130 psi. Hang-up Ring.



75347

75348 TRACTOR TIRE GAUGE

For Air and Liquid-Filled Tires. Pressure Range 5-45 lbs.



75348

75344 LOW PRESSURE TIRE GAUGE

1-20 LBS.

Low pressure readings at their best. Perfect for home garden tractors, golf carts, air springs, and ATVs. Calibrated 1-20 PSI in 1/2 lb. units. Carded. 10/master.



75344

75490 TIRE GAUGE

Straight, Easy to Read. 10-50 psi Pressure Scale. Pocket Clip.



75490

75491 ECONOMY TIRE GAUGE

Angled easy to read. 10-50 psi pressure scale. Pocket clip.



75491

75343 DIGITAL TIRE GAUGE

5-99 lbs.

75343



75528

75528 DIAL TIRE GAUGE 10-60 PSI.

Professional Model for Cars, Vans, & Light Trucks. Easy to Read. Automatic Reset. Pressure Release Valve. Drawn steel Casing. Nickel Plated Brass Chuck.

75493 DELUXE TIRE INFLATOR GAUGE

10-120 psi. Dual Foot, In-Line Design. Heavy Duty. Internal Gauge with Glass Viewing Window.

75493



75496

75496 TIRE INFLATOR GAUGE

10-120 psi. 21 lbs Increments. 12" Heavy Duty Hose.

BATTERY JUMPER CABLES & BATTERY CLAMPS

FORNEY PREMIUM JUMPER CABLES

Heavy Duty Jumper Cables:

Constructed from #4, #2 or #2/0 Welding Cable. Colour-coded 500 Amp Copper Jaw Clamps. All #2/0 Jumper Cables come with 54724-54725 800 Amp Clamps. Includes a carrying case and instructions.



52871



800 Amp

54724
54725



500 Amp

54718
54719



400 Amp

54714
54716

AVAILABLE IN THESE SIZES:

#4 Welding Cable	Cat. No.
12'	52865
16'	52866
20'	52867
25'	52868
#4 Twin Cable	
12'	52870
16'	52871
20'	52872
25'	52873
#2 Welding Cable	
12'	52875
16'	52876
20'	52877
25'	52878
#2/0 Welding Cable	
12'	92012
16'	92016
20'	92020
25'	92025

BATTERY JUMPER CABLES & BATTERY CLAMPS

BATTERY JUMPER CABLES & BATTERY CLAMPS

BOOSTER DUPLEX JUMPER CABLES

CAT. NO.	GAUGE	LENGTH	CLAMP	COLOR	PACKAGING
00146	10	10	50A	Yellow/Yellow	Storage Bag
52869	10	12	200C	Black/Black	Sleeve
00862	8	12	500E	Yellow/Black	Storage Bag
00536	6	16	500E	Orange/Black	Retail Box
00535	4	16	500E	White/Black	Retail Box
00534	4	20	500E	White/Black	Retail Box
00533	2	20	600P	Red/Black	Retail Box

Copper Clad Aluminum Booster Cables

Tough PVC insulation, colour-coded tangle-free dual cable construction.

- Rugged jacket
- Very flexible
- Resists Abrasion, Cut, Tear, Flame, Grease, Oil and Cold temperatures
- Polarity striped (red)
- Cable made in the USA



CONSTRUCTION:

Highly flexible annealed bare copper conductor 30 gauge insulated with a TPE (thermoplastic elastomer) jacket. Operating temperatures range from -40°C to +90°C (-40°F to +194°F). Rated to 600 Volts.

APPLICATION:

Heavy duty booster cables for battery service and SB type connectors for plug in convenience.



BATTERY TERMINALS & CHARGER CLAMPS

BATTERY TERMINAL 8 ga. to 1/0

High quality quickly installed replacement cable ends can be used to restore original configuration or can be used to convert from side post to top post battery or top post to side post battery.



54770 Universal Top Post 60146 2 Per Card(54770)	54766 Universal Top Post (10 X 54770)
54771 Universal Side Post 60147 2 Per Card (54771)	54767 Universal Side Post (10 X 54772)
54772 H.D. Universal Battery Terminal	60148 2 Per Card (54772)

54773 MARINE BATTERY TERMINAL

Commonly used as marine terminals. Also used on some import autos and garden tractors. Best used in fresh water environments.

60149 2 Per Card (54773)

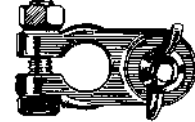

54774 SIDE TERMINAL ADAPTERS

Side Terminal adapters are the least expensive way to use a Top Post Battery in a vehicle equipped with Side Terminal Cables. Sold in pairs.

60150 1 Pair Per Card

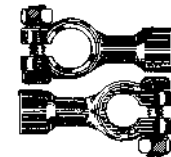

54775 - 54778 CONVERSION POSTS FOR SIDE TERMINALS

Conversion Posts replace the O.E.M. bolts that GM provides to connect the side terminals to your battery. Allows side terminal battery to be used with regular cable ends or excellent for booster terminals.



SOLDER BATTERY TERMINALS

Provides the corrosion resistance of brass in a terminal that is designed for solder installation. #4 - #1 standard wire gauge range.

54776	Solder Terminal - Straight
60153	2 Per Card (54776)
54777	Solder Terminal - Left/Right
60154	2 Per Card (54777)
60155	Side Terminal Posts Male (Pr)



NUTS & BOLTS FOR BATTERY TERMINALS

54781	Top Post 5/16" x 1 3/8"
60156	2 Per Card (54781)
54782	Side Post 3/8" x 5/16"
60157	2 Per Card (54782)



SOLID BRASS BATTERY TERMINALS

More conductive and stronger than lead. Will deliver more starting power. For auto, light truck and marine applications.

84785 Universal Brass Terminal	60157 2 Per Card (84785)
84786 Positive Brass Terminal	60152 1 Per Card (84786)
84787 Negative Brass Terminal	60152 1 Per Card (84787)

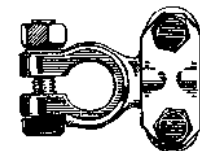

54766 UNIVERSAL TERMINALS

Regular duty (10/display card)

54767 UNIVERSAL TERMINALS

Heavy duty (10/display card)



BATTERY JUMPER CABLES & CHARGER CLAMPS

BATTERY JUMPER CABLES & CHARGER CLAMPS

54727 TUNE-UP CLAMPS 50 AMP

Fine Quality, Copper Plated Battery and Tune-up Replacement Clip. With Red and Black Insulators.

- | |
|---|
| 59012 Negative Black Insulator |
| 59013 Positive Red Insulator |
| 54727 Packaged Set - 59012 and 59013 |



54731 HEAVY DUTY CLIP 54732 REGULAR BATTERY CHARGER CLAMPS 75 AMP

A Good Quality, Medium Size, Copper Plated Battery Charger Clamp. With Red and Black Insulators. Sold by the Pair.

HEAVY DUTY BATTERY CHARGER CLAMPS

500 Amp. Rating. Heavy gauge steel, Zinc Plated, Red and Black insulated handles. Shark - Tooth jaws for extra tight grip. Complete with cable connector.

- | | |
|---|---------------------------|
| 54718 Negative Black | 54719 Positive Red |
| 54722 Packaged (1 Red and 1 Black) | |



54705 EXTRA HEAVY-DUTY BATTERY CHARGER CLAMP 400 AMP

Heavy-Duty, Copper Plated Steel Jaws with Extra Heavy Spring for Positive Clamping Power. Complete Clamp Insulated with Red or Black Vinyl Coating. For Heavy-Duty Charging Jobs.

- | | |
|---|---------------------------|
| 54714 Negative Black | 54716 Positive Red |
| 54705 Packaged (1 Red and 1 Black) | |



SOLID COPPER BOOSTER CLAMP 800 AMP RATING

Solid copper construction assures positive contact and durability. This is probably the best booster cable clamp money can buy. Cable connector included.

- | | |
|-----------------------------|---------------------------|
| 54724 Negative Black | 54725 Positive Red |
|-----------------------------|---------------------------|



BATTERY JUMPER CABLES & CHARGER CLAMPS

60340 OPENING CLIP INVENTORY - WITH INSULATORS

Contains three of each item.
Each package contains 2 clips and 2 insulators.



60343



60344



60345

- | | |
|------------|--|
| 60343..... | Test Clips Gen. Purpose, 5 Amp |
| 60344..... | Crocodile Clips, 5 Amp |
| 60345..... | Pee Wee Clips, 5 Amp |
| 60346..... | Econo Clips, 10 Amp |
| 60347..... | High Grade Clips, 20 Amp |
| 60348..... | Battery & Charger Clips Gen. Purpose
25 Amp |

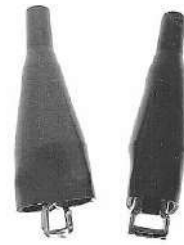

60348



60347



60346

ALLIGATOR CLIPS & INSULATORS (RED & BLACK)

Cat. #	Width	Length	Description
54741	5/8"	2-7/16"	40 amps
54743	5/16"	1-1/2"	Pee-wee
54745	1/2"	2"	Usage multiple
54747	5/16"	2"	6-40 Screw
54749	5/16"	2-1/8"	6-40 Screw
54751	3/4"	3"	25 amps
54752	7/16"	2"	10 amps
54742	Insulator for number		54741
54744	Insulator for number		54743
54746	Insulator for number		54745
54748	Insulator for number		54747
54750	Insulator for number		54749



54740 CLIP ASSORTMENT

2 each of the 12 items above with Display Tray

TEST CLIPS AND CLAMPS

COMPRESSION SPRINGS

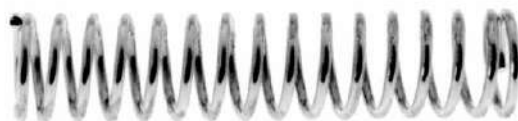

COMPRESSION SPRINGS

CAT.#	CENTURY#	OD Inches	Length Inches	Diam. Inches	No. In Pack	CAT.#	CENTURY#	OD Inches	Length Inches	Diam. Inches	No. In Pack
72600	C-500	5/32	9/16	.123	6	72635	C-702	9/16	1	.054	2
72601	C-510	1/4	1/2	.035	6	72636	C-704	1/2	1-1/2	.041	2
72602	C-516	5/32	1	.011	6	72637	C-706	9/16	1-3/8	.072	2
72603	C-520	3/16	7/8	.016	6	72638	C-712	11/16	1-1/4	.092	2
72604	C-526	3/16	1	.028	6	72639	C-714	3/8	2-1/4	.062	2
72605	C-530	7/32	1	.020	6	72640	C-720	1/2	1-3/4	.062	2
72606	C-532	3/16	1	.013	6	72641	C-724	7/16	2	.054	2
72607	C-550	3/16	1	.016	6	72642	C-730	13/32	2-3/4	.047	2
72608	C-554	1/4	1	.020	6	72643	C-736	1/2	2-3/4	.072	2
72609	C-556	5/16	5/8	.026	6	72644	C-740	5/8	2-1/2	.080	2
72610	C-562	1/4	1	.035	6	72645	C-742	5/8	2-3/4	.054	2
72611	C-566	3/8	3/4	.032	6	72646	C-750	3/4	2	.080	2
72612	C-570	1/8	1-3/8	.014	6	72647	C-752	15/16	2	.080	2
72613	C-576	5/32	1-3/8	.016	6	72648	C-756	23/32	3-1/2	.041	2
72614	C-578	3/16	1-3/8	.013	6	72649	C-766	9/16	3	.054	2
72615	C-580	3/16	1-3/8	.028	6	72650	C-782	5/8	3	.080	2
72616	C-582	3/16	1-3/8	.016	6	72651	C-792	7/8	3	.105	2
72617	C-600	7/32	1-3/8	.020	4	72652	C-802	1-3/8	4-3/8	.148	1
72618	C-604	7/32	1-3/8	.023	4	72653	C-806	1-1/2	3-1/4	.148	1
72619	C-608	1/4	1-3/8	.020	4	72654	C-814	1-3/8	2-1/2	.135	1
72620	C-612	9/32	1-3/8	.028	4	72655	C-818	1-1/8	4	.120	2
72621	C-614	5/16	1-1/4	.041	4	72656	C-822	15/16	4	.148	2
72622	C-624	3/8	1-1/8	.041	4	72657	C-826	1	3-1/2	.120	2
72623	C-632	7/16	1-1/16	.041	4	72658	C-830	1-1/8	3	.105	2
72624	C-650	7/32	1-3/4	.013	4	72659	C-832	1	3	.120	2
72625	C-652	7/32	1-3/8	.028	4	72660	C-834	1-3/16	2-3/4	.120	2
72626	C-660	5/16	1-3/4	.016	4	72661	C-836	7/8	4	.080	2
72627	C-664	11/32	1-1/2	.047	4	72662	C-838	3/4	3-1/2	.080	2
72628	C-668	3/8	1-1/2	.026	4	72663	C-850	5/8	5	.091	2
72629	C-672	3/8	1-3/4	.035	4	72664	C-856	3/4	6	.091	2
72630	C-676	7/16	2-1/8	.032	4	72665	C-858	11/16	6	.072	2
72631	C-680	5/16	2	.047	4	72666	C-864	7/8	6	.091	1
72632	C-690	7/16	2-1/4	.041	2	72667	C-874	1-3/8	6	.120	1
72633	C-692	5/8	1-11/2	.041	2	72668	C-878	5/8	9	.080	1
72634	C-700	1/2	1	.062	2	72669	C-892	1-1/8	7	.162	1

High quality steel line of springs cover a variety of uses in homes & industry. Including: screen doors, chaise lounges, toys, lawn & garden equipment, industrial and farm equipment, business machines, cars, trucks, boats, RV's, & many more. All springs zinc plated, baked for rust resistant finish, heat treated for performance & longevity. Made in U.S.A.

EXTENSION SPRINGS

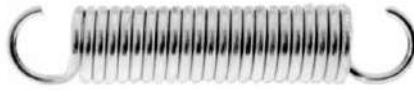

EXTENSION SPRINGS

CAT.#	CENTURY#	OD Inches	Length Inches	Diam. Inches	No. In Pack	CAT.#	CENTURY#	OD Inches	Length Inches	Diam. Inches	No. In Pack
72506	C-1	1/8	1-1/2	.015	2	72554	C-209	3/8	4-1/2	.028	2
72507	C-5	5/32	1-1/2	.020	2	72555	C-215	3/8	3-3/4	.041	2
72508	C-13	7/32	1-1/2	.023	2	72556	C-219	15/32	4-1/2	.041	2
72509	C-19	1/4	1-1/2	.035	2	72557	C-221	1/2	4-1/2	.062	2
72510	C-23	9/32	1-1/2	.025	2	72558	C-223	1/2	5	.072	2
72511	C-25	5/16	1-1/2	.020	2	72559	C-227	11/16	4-3/4	.091	2
72512	C-29	11/32	1-1/2	.028	2	72560	C-231	9/16	6	.072	2
72513	C-31	7/16	1-1/2	.028	2	72561	C-233	1/4	6	.034	2
72514	C-33	7/16	1-1/2	.047	2	72562	C-235	5/16	6	.028	2
72515	C-51	1/8	1-7/8	.014	2	72563	C-239	3/8	6-1/2	.047	2
72516	C-55	5/32	1-7/8	.020	2	72564	C-243	5/8	6-1/2	.054	2
72517	C-63	7/32	1-7/8	.023	2	72565	C-251	1-1/8	16	.105	1
72518	C-67	1/4	1-7/8	.020	2	72566	C-253	9/16	16-1/2	.054	1
72519	C-69	1/4	1-7/8	.035	2	72567	C-257	13/16	4-1/2	.091	2
72520	C-73	9/32	1-7/8	.025	2	72568	C-259	13/16	4	.120	2
72521	C-77	11/32	1-7/8	.025	2	72569	C-261	1-1/16	5-1/2	.120	1
72522	C-81	7/16	1-7/8	.028	2	72570	C-263	7/8	6	.091	1
72523	C-83	7/16	1-7/8	.047	2	72571	C-265	1-1/16	7	.105	1
72524	C-103	1/8	2-1/2	.018	2	72572	C-267	1-1/4	6-1/2	.162	1
72525	C-105	5/32	2-1/2	.020	2	72573	C-269	1	7	.135	1
72526	C-111	3/16	2-1/2	.025	2	72574	C-271	1-1/16	8-1/2	.080	1
72527	C-115	1/4	2-1/2	.016	2	72575	C-273	1-1/8	8-1/2	.148	1
72528	C-117	1/4	2-1/2	.020	2	72576	C-275	1-1/8	7-1/2	.091	1
72529	C-119	1/4	2-1/2	.035	2	72577	C-277	3/4	6-1/2	.091	1
72530	C-131	7/16	2-1/2	.028	2	72578	C-281	3/8	5-1/2	.062	2
72531	C-133	7/16	2-1/2	.047	2	72579	C-285	3/8	5	.034	2
72532	C-135	7/16	2	.062	2	72580	C-287	5/16	5	.031	2
72533	C-139	7/16	3-1/2	.054	2	72581	C-289	5/16	5	.034	2
72534	C-141	5/8	2-1/2	.072	2	72582	C-293	3/8	6-3/4	.062	1
72535	C-143	9/16	3	.054	2	72583	C-301	1-1/2	11-1/2	.135	1
72536	C-155	5/16	3	.028	2	72584	C-303	1	12	.105	1
72537	C-157	1/4	3-1/4	.025	2	72585	C-307	1-1/16	12	.135	1
72538	C-161	7/16	2-3/4	.034	2	72586	C-311	7/16	10-1/4	.041	1
72539	C-163	7/16	3-1/2	.047	2	72587	C-313	1/2	8-1/2	.047	1
72540	C-165	1/2	1-5/8	.080	2	72588	C-315	7/16	8-1/2	.047	1
72541	C-171	3/4	2	.105	2	72589	C-317	5/8	8-1/2	.091	1
72542	C-173	3/4	2-1/4	.105	2	72590	C-319	9/16	8-1/2	.054	1
72543	C-175	3/4	2-7/16	.105	2	72591	C-321	5/8	8-1/2	.062	1
72544	C-177	3/4	2-5/8	.105	2	72592	C-323	5/8	8-1/2	.080	1
72545	C-179	9/16	2-7/8	.072	2	72593	C-325	7/8	8-1/2	.062	1
72546	C-181	5/8	3-1/4	.072	2	72594	C-329	7/8	8-1/2	.105	1
72547	C-183	9/16	4	.047	2	72595	C-333	7/8	9	.135	1
72548	C-185	3/4	3-1/2	.062	2	72596	C-337	1	8-1/2	.120	1
72549	C-187	3/4	3-7/8	.105	2	72597	C-339	1-1/4	10	.148	1
72550	C-189	3/4	3-1/8	.105	2	72598	Drawbar/Porch Swing Spring				1
72551	C-191	3/4	3-3/4	.105	2			1-9/16	7-3/4	.227	
72552	C-193	3/8	4	.034	2	72599	Spring Assortment - 100 pcs.				1
72553	C-205	1/4	5	.034	2						

EXTENSION SPRINGS

SPRING CENTRE

72500 FORNEY SPRING DISPLAY - 217 Springs in 94 Sizes

Complete
Display
Packaged for
Self Service

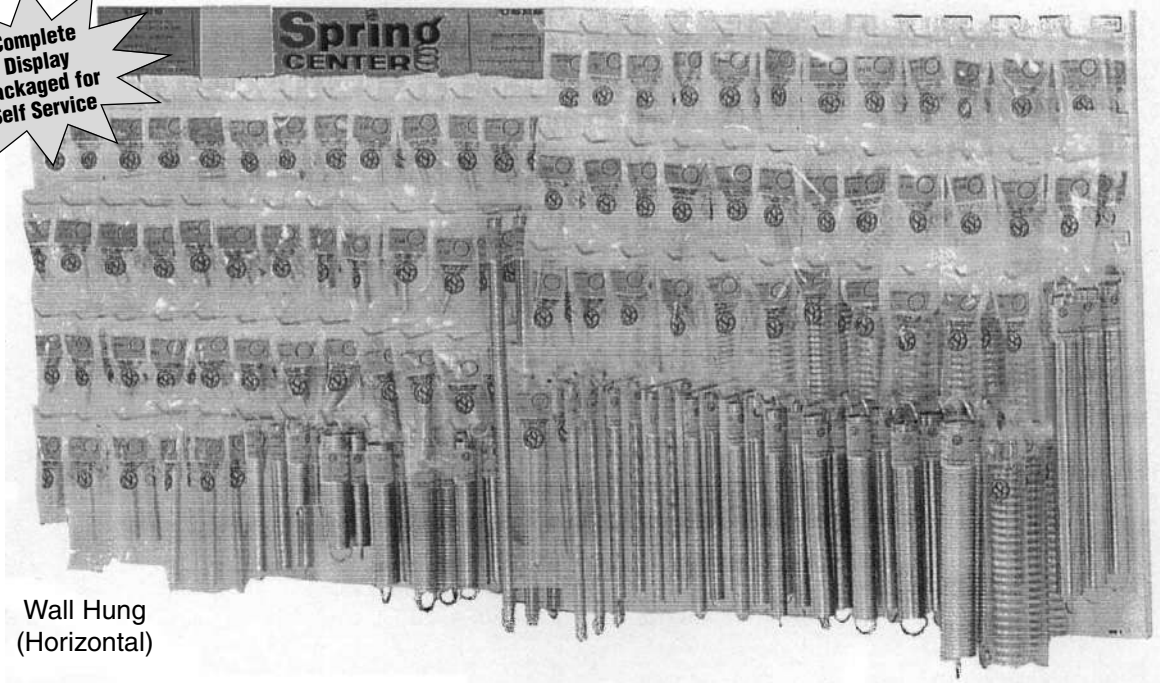

Wall Hung
(Horizontal)

72501 FORNEY SPRING DISPLAY - 389 Springs in 163 Sizes

Complete
Display
Packaged for
Self Service

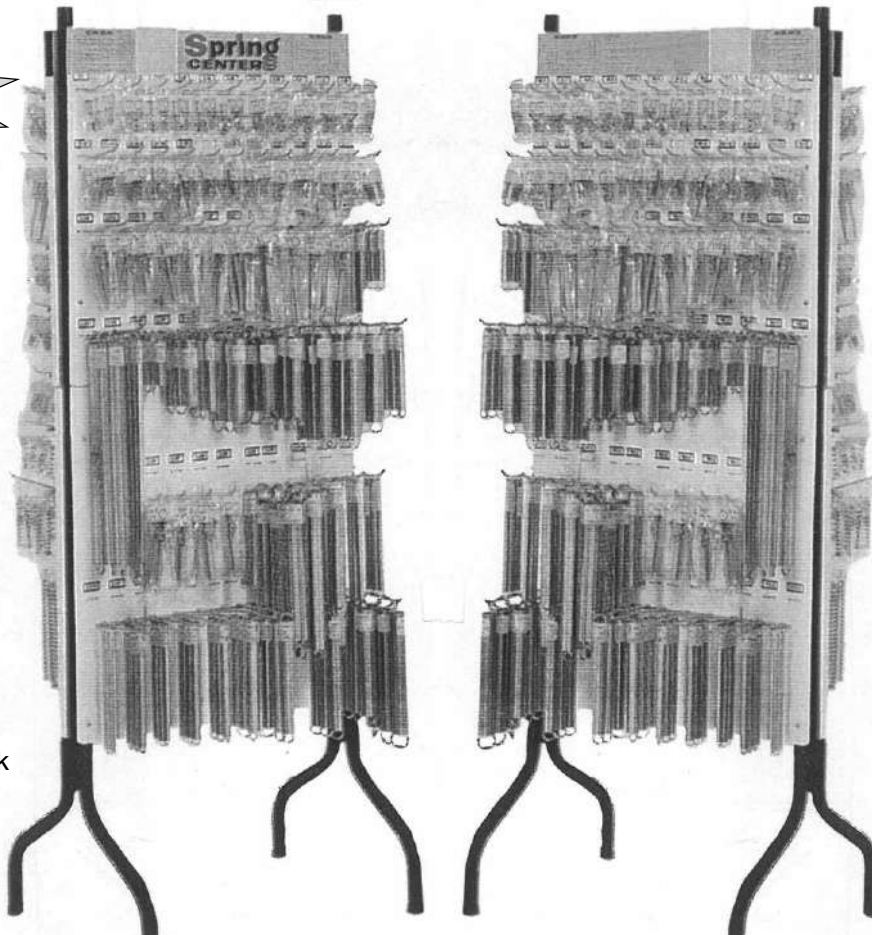

Back to Back
on Legs

PRESSURE WASHER PARTS & ACCESSORIES

PRESSURE WASHER COUNTER DISPLAY PARTS & ACCESSORIES

OUR BEST
SELLING
ACCESSORIES

32-PIECE Pressure Washer Counter Display

CAT # 75103

Shipped 2 Deep with
FREE rack!



CAT#75108 M22F x 3/8" Female Screw Coupling
CAT#75117 M22F x 3/8" Male Screw Nipple
CAT#75127 1/4" Female Socket Quick Coupler
CAT#75128 3/8" Male Socket Quick Coupler
CAT#75129 3/8" Female Socket Quick Coupler
CAT#75134 1/4" Male Quick Connect Plug
CAT#75136 3/8" Male Quick Connect Plug
CAT#75137 3/8" Female Quick Connect Plug

CAT#75148 5-Pc 4.0mm Quick Connect Spray Nozzle Assort.
CAT#75149 5-Pc 4.5mm Quick Connect Spray Nozzle Assort.
CAT#75153 15°x4.5mm Quick Connect Chiseling Nozzle
CAT#75155 25°x4.5mm Quick Connect Flushing Nozzle
CAT#75156 40°x4.5mm Quick Connect Wash Nozzle
CAT#75157 0°x4.5mm Quick Connect Blasting Nozzle
CAT#75166 Multi-Regulator Nozzle
CAT#75180 Spray Gun

Also Available:

75101 LARGE OPENING INVENTORY PRESSURE WASHER DISPLAY (Not Shown)

Fornney

HEAD OFFICE: Regina, Saskatchewan • Telephone: 1-800-667-8161 Fax: 1-800-404-3551
EASTERN WAREHOUSE: Hawkesbury Ontario • Telephone: 1-888-811-0889 Fax: 1-888-811-1120

PRESSURE WASHER PARTS & ACCESSORIES

PRESSURE WASHER ACCESSORIES

HP SCREW COUPLINGS

75106

HP Screw Coupling

1/4" FNPT x M22
300° F, 5800 PSI, cat. #75190
replacement o-ring



75107

HP Screw Coupling

1/4" MNPT x M22
300° F, 5800 PSI, cat. #75190
replacement o-ring

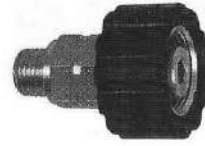

75108

HP Screw Coupling

3/8" FNPT x M22
300° F, 5800 PSI, cat. #75190
replacement o-ring



75109

HP Screw Coupling

3/8" MNPT x M22
300° F, 5800 PSI, cat. #75190
replacement o-ring



HP SCREW NIPPLES

75114

HP Screw Nipple

1/4" FNPT x M22
300° F, 5800 PSI



75115

HP Screw Nipple

1/4" MNPT x M22
300° F, 5800 PSI



75116

HP Screw Nipple

3/8" FNPT x M22
300° F, 5800 PSI

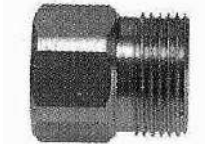

75117

HP Screw Nipple

3/8" MNPT x M22
300° F, 5800 PSI

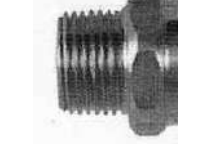

75118

HP Screw Nipple

1/4" FNPT x M22 Italian
300° F, 5800 PSI



75123

HP Quick Coupler Plug

1/4" Male Plug x M22
300° F, 5800 PSI

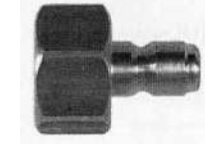

75126

HP Quick Coupler (brass)

1/4" MNPT
300° F, 5500 PSI



75127

HP Quick Coupler (brass)

1/4" FNPT
300° F, 5500 PSI

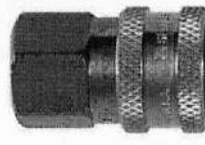

NEW! **75119** Stainless Steel

NEW! **75120** Stainless Steel

75128

HP Quick Coupler (brass)

3/8" MNPT
300° F, 4200 PSI



75129

HP Quick Coupler (brass)

3/8" FNPT
300° F, 4200 PSI

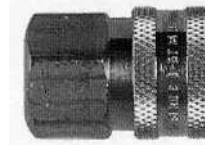

NEW! **75121** Stainless Steel

NEW! **75122** Stainless Steel

PRESSURE WASHER ACCESSORIES

PRESSURE WASHER ACCESSORIES

HP QUICK COUPLER PLUGS

75134

HP Quick Coupler Plug
1/4" MNPT
300° F, 5500 PSI



75135

HP Quick Coupler Plug
1/4" FNPT
300° F, 5500 PSI

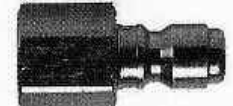

NEW!

75130 Stainless Steel

NEW!

75131 Stainless Steel

75136

HP Quick Coupler Plug
3/8" MNPT
300° F, 5500 PSI



75137

HP Quick Coupler Plug
3/8" FNPT
300° F, 5500 PSI



NEW!

75132 Stainless Steel

NEW!

75133 Stainless Steel

75140

Non-rotating Sewer Nozzle (SS)
1/4" FNPT
300° F, 5500 PSI



75141

Non-rotating Sewer Nozzle (SS)
1/8" FNPT
300° F, 5500 PSI



75142

Rotating Sewer Nozzle (SS)
1/4" FNPT, 3000 PSI
Orifice of 4.5



SOAP & SPRAY NOZZLES

75150

Soap Nozzle (black)
1/4" quick connect x 65° flat spray, 4.0 orifice, 300° F

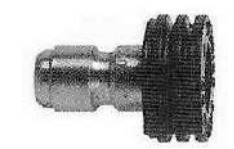

75153

Soap Nozzle (yellow)
1/4" quick connect x 15° chisel spray, 4.5 orifice, 300° F



75154

Soap Nozzle (yellow)
1/4" quick connect x 15° chisel spray, 5.5 orifice, 300° F



75155

Soap Nozzle (green)
1/4" quick connect x 25° flushing spray, 4.5 orifice, 300° F



75156

Soap Nozzle (white)
1/4" quick connect x 40° wide spray, 4.5 orifice, 300° F

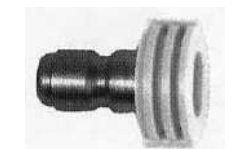

75157

Soap Nozzle (red)
1/4" quick connect x 0° blasting spray, 4.5 orifice, 300° F



PRESSURE WASHER ACCESSORIES

SOAP & SPRAY NOZZLES

75148

Spray & Soap Nozzles

5-pack assortment
1/4" quick connect, 4.0 orifice, (0,15, 25, 40 degrees soap nozzles & one soap nozzle)



75149

Spray & Soap Nozzles

5-pack assortment
1/4" quick connect, 4.5 orifice, (0,15, 25, 40 degrees soap nozzles & one soap nozzle)



NOZZLES & PARTS

75160

Rotating Spray Turbo Nozzle

1/4" FNPT, 190° F, 4.5 orifice, 3600 PSI



75161

Rotating Spray Turbo Nozzle

1/4" FNPT, 212° F, 4.5 orifice, 3600 PSI



75167

Adjustable Side Handle

fits 1/4" wand



75172

Soap & Chemical Strainer with built-in SS check valve, fits 1/4" and 3/8" hose



75173

Inlet Water Filter Strainer

1/2" FNPT x 1/2" MNPT, 140° F, 145 PSI



75176

Turbo Nozzle Filter Strainer

1/4" quick connect, 190° F, 5000 PSI



75166

Multi-Reg Nozzle

1/4" FNPT x 0 to 80°, flat spray, 300° F, 4.5 orifice, 3000 PSI



- 75190** O-RING FOR HP SCREW COUPLING
- 75191** O-RING FOR 1/4" HP SCREW COUPLING
- 75192** O-RING FOR 3/8" HP SCREW COUPLING

75180

Spray Gun

4000 PSI
3/8" FNPT Inlet x 1/4" FNPT Outlet



75168 36" Molded Grip Lance



75169 36" Molded Grip Lance with side handle

PRESSURE WASHER ACCESSORIES

PRESSURE WASHER HOSES

75183
50' Pressure
Washer Hose
3/8" MNPT, 3000 PSI



75185
1/4" x 50' Pressure
Washer Hose
with M22 Female ends,
3000 PSI, 140° F



75186
1/4" x 25' Pressure
Washer Hose
with M22 Female ends,
3000 PSI, 140° F



75187 1/4" m (4.0) SLUDGE PUMP
4000 PSI



75187
75188

75188 1/4" m (4.5) SLUDGE PUMP
4000 PSI

75189 25 ft. DISCHARGE HOSE FOR
SLUDGE PUMP

75189



75193 PREMIUM PRESSURE WASHER
DETERGENT
(makes 5 gallons.)



75193

75194 15 pc. O-RING KIT
(5 each - 75190, 75191, 75192)

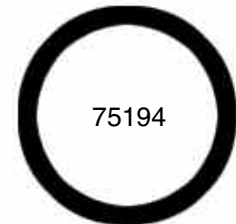

75194

75195 1/2" x 260' TEFLON TAPE



75195

75196 UPSTREAM SOAP INJECTOR
(1.5-4.0 GPM) with 4-ft Suction Hose

75196



PRESSURE WASHER FITTINGS

pressure washer fittings

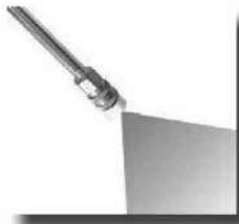

White 40° Nozzle

This is a wash nozzle. Its wide spray pattern disperses the water pressure over a large area and is recommended for rinsing and moderate washing. Uses: Washing down aluminum siding, cleaning windows, washing vehicles, spraying sidewalks, driveways and patios.



Green 25° Nozzle

This is a flushing nozzle. With a narrower spray pattern than the 40 nozzle and with more concentrated spray pressure, this nozzle is best suited for flushing dirt, mud and grime. Uses: Wet sweeping leaves from walks, curbs and driveways, cleaning stable floors, washing swimming pool bottoms and cleaning barbecue grills.



Yellow 15° Nozzle

This is a chiseling nozzle. The spray should be directed at a 45 angle to the surface and be used like a scraper to remove paint, grease and dirt. Uses: Surface preparation (removing peeling paint and mildew stains), cleaning gutters and downspouts and bugs from trucks.



Red 0° Nozzle

This is a blasting nozzle. It delivers a very concentrated stream of water. Care should be used to avoid gouging wood or damaging fragile surfaces. Uses: Removing weeds from sidewalk cracks, stubborn mineral stains and chewing gum from concrete, masonry, aluminum and steel, caked mud from equipment and cleaning lawn mower undersides.

The orifice size of the nozzle determines the operating pressure of your machine. As a rule, the smaller the orifice, the greater the restriction of water flowing through the machine. This causes the pressure to increase. Choosing a nozzle with too small an orifice will limit water flow and possibly create an excessive load on the machine. Too large and it will reduce operating pressure.

Use the table below to select the proper size for your machine. Match the operating pressure (PSI of your machine to the gallons per minute (GPM).

NOZZLE ORIFICE SIZE	POUNDS PER SQUARE INCH (PSI)																		
	500	600	700	800	1000	1500	2000	2500	3000	3500	4000	4500	5000	5500	6000	6500	7000	7500	8000
	PSI	PSI	PSI	PSI	PSI	PSI	PSI	PSI	PSI	PSI	PSI	PSI	PSI	PSI	PSI	PSI	PSI	PSI	PSI
2	0.71	0.77	0.84	0.89	1	1.2	1.4	1.6	1.7	1.9	2	2.1	2.2	2.3	2.4	2.5	2.6	2.7	2.8
2.5	0.9	1	1	1.1	1.3	1.6	1.8	2	2.2	2.3	2.5	2.7	2.8	2.9	3.1	3.2	3.3	3.4	3.5
3	1.1	1.2	1.3	1.4	1.5	1.8	2.1	2.4	2.6	2.8	3	3.2	3.4	3.5	3.7	3.8	4	4.1	4.2
3.5	1.3	1.4	1.5	1.6	1.8	2.2	2.5	2.8	3.1	3.3	3.5	3.7	3.9	4.1	4.3	4.5	4.6	4.8	4.9
4	1.4	1.6	1.7	1.8	2	2.5	2.8	3.2	3.5	3.7	4	4.2	4.5	4.7	4.9	5.1	5.3	5.5	5.7
4.5	1.6	1.7	1.9	2	2.3	2.8	3.2	3.6	3.9	4.2	4.5	4.8	5	5.3	5.5	5.7	6	6.2	6.4
5	1.8	1.9	2.1	2.2	2.5	3.1	3.5	4	4.3	4.7	5	5.3	5.6	5.9	6.1	6.4	6.6	6.8	7.1
5.5	1.9	2.1	2.3	2.5	2.8	3.4	3.9	4.1	4.8	5.1	5.5	5.8	6.2	6.4	6.7	7	7.3	7.5	7.8
6	2.1	2.3	2.5	2.7	3	3.7	4.2	4.7	5.2	5.6	6	6.4	6.7	7	7.3	7.6	7.9	8.2	8.5
6.5	2.3	2.5	2.7	2.9	3.3	4	4.6	5.1	5.6	6.1	6.5	6.9	7.3	7.6	8	8.3	8.6	8.9	9.2
7	2.5	2.7	2.9	3.1	3.5	4.3	4.9	5.5	6.1	6.5	7	7.4	7.8	8.2	8.6	8.9	9.3	9.6	9.9
7.5	2.7	2.9	3.1	3.4	3.8	4.6	5.3	5.9	6.5	7	7.5	8	8.4	8.8	9.2	9.6	9.9	10.3	10.6
8	2.8	3.1	3.4	3.6	4	4.9	5.7	6.3	6.9	7.5	8	8.5	8.9	9.4	9.8	10.2	10.6	11	11.3
9	3.2	3.5	3.8	4	4.5	5.5	6.4	7.1	7.8	8.4	9	9.6	10.1	10.6	11	11.5	11.9	12.3	12.7
10	3.5	3.9	4.2	4.5	5	6.1	7.1	7.9	8.7	9.4	10	10.6	11.2	11.7	12.2	12.7	13.2	13.7	14.1
12	4.2	4.6	5	5.4	6	7.3	8.5	9.5	10.4	11.2	12	12.7	13.4	14.1	14.7	15.3	15.9	16.4	17
15	5.3	5.8	6.3	6.7	7.5	9.2	10.6	11.9	13	14.1	15	15.9	16.8	17.6	18.4	19.1	19.8	20.5	21.2

SPRING CENTRE

72505 WALL DISPLAY 2 FT X 2 FT - 126 SPRINGS IN 57 SIZES

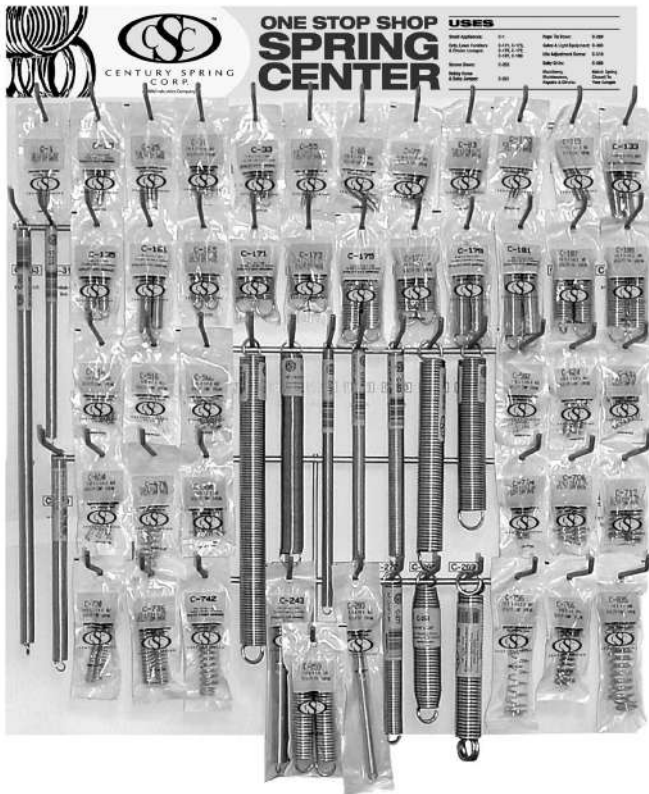

Type: wall hung
Size: 2' x 2' 3"
Weight: 28 lbs. est.
No. of Springs: 126
No. of Items: 57
Qty of Each: 1

This assortment is perfect for retailers with minimal wall space!

This display offers 57 items from our line of springs. It features 39 of our most popular replacement extension springs, plus 18 of our most popular compression springs. The display is a customer-built one piece rack for easy installation and presents an attractive and effective point of sale display.

Display includes a plan-o-gram to make re-ordering and refilling easy.

ELECTRICAL CONNECTORS & PLUGS



Cat. #222
Polarized Connector - 15A



Cat. #SA993
Extension Cord Connector - 15A



Cat. #1709
Black Round Male Plug - 15A



Cat. #5965
Yellow Plug - Hinged - 15A



Cat. #4867
Yellow Vinyl Male Plug - 15A



Cat. #4887
Yellow Vinyl Female Plug - 15A



Cat. #5969
Yellow Connector Hinged - 15A

COBALT DRILLS

NATIONAL AEROSPACE STANDARD 907, TYPE J, COBALT JOBBER LENGTH DRILLS



Cobalt HSS, Gold Finish, 135° Split Point FRACTIONAL

Developed for drilling holes in hard, tough materials such as stainless steel, titanium high temperature and high strength alloys. They are made of heat resistant cobalt steel and are of heavy duty construction. Furnished with 135° Type P3 split point unless otherwise specified.

COBALT FRACTIONAL



CAT# 20011 COBALT DRILL ASSORTMENT 115 PC (COC29)

(INCLUDES ALL FRACTIONAL SIZES)

6 EA: 1/16", 5/64", 3/32", 7/64", 1/8", 9/64", 5/32", 11/64", 3/16", 13/64", 7/32", 1/4"

3 EA: 15/64", 17/64", 9/32", 19/64", 5/16", 21/64", 11/32", 23/64", 3/8"

2 EA: 25/64", 13/32", 27/64", 7/16", 29/64", 15/32", 31/64", 1/2"

INCLUDES DISPLAY

Note: All 135° Split Point Bits begin the cutting action immediately and penetrate faster with less pressure. This design prevents walking. No center punch needed.

COBALT DRILLS

CAT#	METCO#	DESCRIPTION	CAT#	METCO#	DESCRIPTION
20039	CO116	1/16 SPLIT PT COBALT DRILL	20054	CO1964	19/64 SPLIT PT COBALT DRILL
20040	CO564	5/64 SPLIT PT COBALT DRILL	20055	CO516	5/16 SPLIT PT COBALT DRILL
20041	CO332	3/32 SPLIT PT COBALT DRILL	20056	CO2164	21/64 SPLIT PT COBALT DRILL
20042	CO764	7/64 SPLIT PT COBALT DRILL	20057	CO1132	11/32 SPLIT PT COBALT DRILL
20043	CO18	1/8 SPLIT PT COBALT DRILL	20058	CO2364	23/64 SPLIT PT COBALT DRILL
20044	CO964	9/64 SPLIT PT COBALT DRILL	20059	CO38	3/8 SPLIT PT COBALT DRILL
20045	CO532	5/32 SPLIT PT COBALT DRILL	20060	CO2564	25/64 SPLIT PT COBALT DRILL
20046	CO1164	11/64 SPLIT PT COBALT DRILL	20061	CO1332	13/32 SPLIT PT COBALT DRILL
20047	CO316	3/16 SPLIT PT COBALT DRILL	20062	CO2764	27/64 SPLIT PT COBALT DRILL
20048	CO1364	13/64 SPLIT PT COBALT DRILL	20063	CO716	7/16 SPLIT PT COBALT DRILL
20049	CO732	7/32 SPLIT PT COBALT DRILL	20064	CO2964	29/64 SPLIT PT COBALT DRILL
20050	CO1564	15/64 SPLIT PT COBALT DRILL	20065	CO1532	15/32 SPLIT PT COBALT DRILL
20051	CO14	1/4 SPLIT PT COBALT DRILL	20066	CO3164	31/64 SPLIT PT COBALT DRILL
20052	CO1764	17/64 SPLIT PT COBALT DRILL	20067	CO12	1/2 SPLIT PT COBALT DRILL
20053	CO932	9/32 SPLIT PT COBALT DRILL			



CAT# 20068 COBALT DRILL SET 13 PC. (COS13) 1/16" - 1/4" by 64ths
 CAT# 20069 COBALT DRILL SET 15 PC. (COS15) 1/16" - 1/2" by 32nds
 CAT# 20070 COBALT DRILL SET 21 PC. (COS21) 1/16" - 3/8" by 64ths
 CAT# 20071 COBALT DRILL SET 29 PC. (COS29) 1/16" - 1/2" by 64ths

Cutting & Cooling fluids make the job easier and greatly increase the life of the drill.

JOBBER DRILLS

NATIONAL AEROSPACE STANDARD 907, TYPE B, JOBBER LENGTH DRILLS



High Speed Steel, Surface Treated, 135° Split Point

Of heavier construction, this drill will afford excellent results in hard steels, titanium and other hard materials and is particularly suitable for power and portable drilling. Surface treated for abrasion resistance and improved chip flow.



SURFACE TREATED FRACTIONAL



CAT# 20015 BLUE JOBBER DRILL ASSORTMENT 115 PC. (BJHDC29)

6 EA: 1/16", 5/64", 3/32", 7/64", 1/8", 9/64",
5/32", 11/64", 3/16", 13/64", 7/32", 1/4"
3 EA: 15/64", 17/64", 9/32", 19/64", 5/16",
21/64", 11/32", 23/64", 3/8"
2 EA: , 25/64", 13/32", 27/64", 7/16", 29/64",
15/32", 31/64", 1/2"

INCLUDES DISPLAY

Note: All 135° Split Point Bits begin the cutting action immediately and penetrate faster with less pressure. This design prevents walking. No center punch needed.

CAT#	METCO#	DESCRIPTION	CAT#	METCO#	DESCRIPTION
20184	BJHD164	1/64 HSS BLUE JOB. LGTH DRILL	20200	BJHD1764	17/64 SPLIT PT JOBBER DRILL
20185	BJHD132	1/32 HSS BLUE JOB. LGTH DRILL	20201	BJHD932	9/32 SPLIT PT JOBBER DRILL
20186	BJHD364	3/64 HSS BLUE JOB. LGTH DRILL	20202	BJHD1964	19/64 SPLIT PT JOBBER DRILL
Above drills do not have Split Point			20203	BJHD516	5/16 SPLIT PT JOBBER DRILL
20187	BJHD116	1/16 SPLIT PT JOBBER DRILL	20204	BJHD2164	21/64 SPLIT PT JOBBER DRILL
20188	BJHD564	5/64 SPLIT PT JOBBER DRILL	20205	BJHD1132	11/32 SPLIT PT JOBBER DRILL
20189	BJHD332	3/32 SPLIT PT JOBBER DRILL	20206	BJHD2364	23/64 SPLIT PT JOBBER DRILL
20190	BJHD764	7/64 SPLIT PT JOBBER DRILL	20207	BJHD38	3/8 SPLIT PT JOBBER DRILL
20191	BJHD18	1/8 SPLIT PT JOBBER DRILL	20208	BJHD2564	25/64 SPLIT PT JOBBER DRILL
20192	BJHD964	9/64 SPLIT PT JOBBER DRILL	20209	BJHD1332	13/32 SPLIT PT JOBBER DRILL
20193	BJHD532	5/32 SPLIT PT JOBBER DRILL	20210	BJHD2764	27/64 SPLIT PT JOBBER DRILL
20194	BJHD1164	11/64 SPLIT PT JOBBER DRILL	20211	BJHD716	7/16 SPLIT PT JOBBER DRILL
20195	BJHD316	3/16 SPLIT PT JOBBER DRILL	20212	BJHD2964	29/64 SPLIT PT JOBBER DRILL
20196	BJHD1364	13/64 SPLIT PT JOBBER DRILL	20213	BJHD1532	15/32 SPLIT PT JOBBER DRILL
20197	BJHD732	7/32 SPLIT PT JOBBER DRILL	20214	BJHD3164	31/64 SPLIT PT JOBBER DRILL
20198	BJHD1564	15/64 SPLIT PT JOBBER DRILL	20215	BJHD12	1/2 SPLIT PT JOBBER DRILL
20199	BJHD14	1/4 SPLIT PT JOBBER DRILL			



- CAT# 20216 SPLIT PT DRILL SET 13 PC. (BJHDS13) 1/16 - 1/4 by 64ths
- CAT# 20217 SPLIT PT DRILL SET 15 PC. (BJHDS15) 1/16 - 1/2 by 32nds
- CAT# 20218 SPLIT PT DRILL SET 21 PC. (BJHDS21) 1/16 - 3/8 by 64ths
- CAT# 20219 SPLIT PT DRILL SET 29 PC. (BJHDS29) 1/16 - 1/2 by 64ths
- CAT# 20220 SPLIT PT DRILL SET 115 PC. (BJHDS115)

1/16 - 1/2 by 64ths, #1 thru #60, A thru Z

JOBBER DRILLS

DRILLING & CUTTING TIPS

DRILLING AND CUTTING TIPS



Always use cutting or cooling fluids when drilling or cutting metal. Cutting fluids make the job much easier while preserving the life of your drill bit or holesaw.



Insert the drill shank into the chuck and tighten evenly at all three chuck key positions.

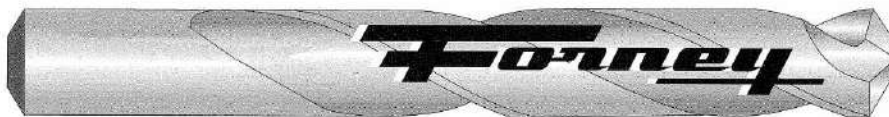

Always apply steady, straight-in-the-hole pressure. Avoid side to side movement.

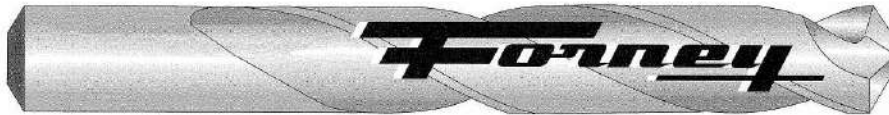

If possible; adjust drill speed to the job. As a general rule, the harder the material...the slower the rpm's.

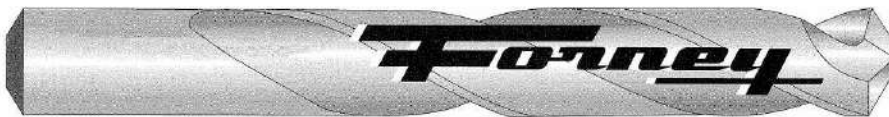

Failure to heed all safety rules; instructions and warnings can result in serious injury.

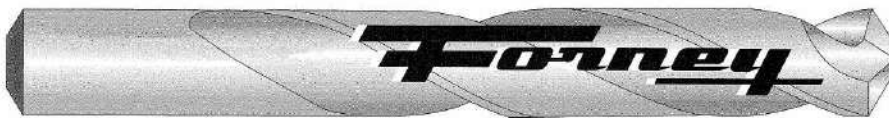

Safety goggles or full face shield worn over safety glasses with side shields (ANSI Z87.1) should be worn at all times whenever drilling or cutting.

MAGNETIZER/DEMAGNETIZER

MAGNETIZER/DEMAGNETIZER

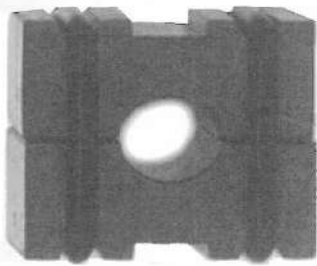

The Amazing MagDeMag

Specially designed to Magnetize or Demagnetize screwdrivers, insert bits, retrieval tools and any other small tool to help speed up repair and assembly jobs.



**CAT# 20034 MAG DE-MAG
ASSORTMENT 36 PC. (MAGD)
INCLUDES FREE DISPLAY (CAT# 10627)**

CAT#	METCO#	DESCRIPTION
21305	MAG01	MAG - DEMAG (Sold by the piece.)
21313	N/A	MAG - DEMAG - 36 Refills (21305) Display Refill

CUTTING & COOLING FLUIDS



**CAT# 20856
EEZFOAM**

EEZ FOAMY

17 OZ. SPRAY FOAM CUTTING FLUID

A foam, you spray directly on the work piece or tool, without running like most fluids. Excellent for tapping, threading, drilling, reaming, milling on ferrous metals and non ferrous alloys.



CAT# 20857

CAT# 20858

CAT# 20859

TAP MAGIC PRO TAP

Great for all cutting, regardless of what you cut or how you cut it. Completely biodegradable and ecologically safe.

TAP MAGIC PROCUT FLUID 4 OZ
(CFPT1)

TAP MAGIC PROCUT FLUID PINT
(CFPT2)

TAP MAGIC PROCUT FLUID GALLON
(CFPT3)

LEFT HAND DRILLS

LEFT HAND SCREW MACHINE LENGTH DRILLS

Requires a reversing drill



HIGH SPEED STEEL
BRIGHT FINISH
118 POINT

The Easy E-Z Out

A great method of drilling out and removing broken studs, bolts and screws. Using a left hand drill bit for removal, eliminates tightening or spinning the work deeper. Many times, the left hand drill bit will spin the broken piece out without having to use a screw extractor. If a screw extractor is still necessary, try our super tough screw extractors

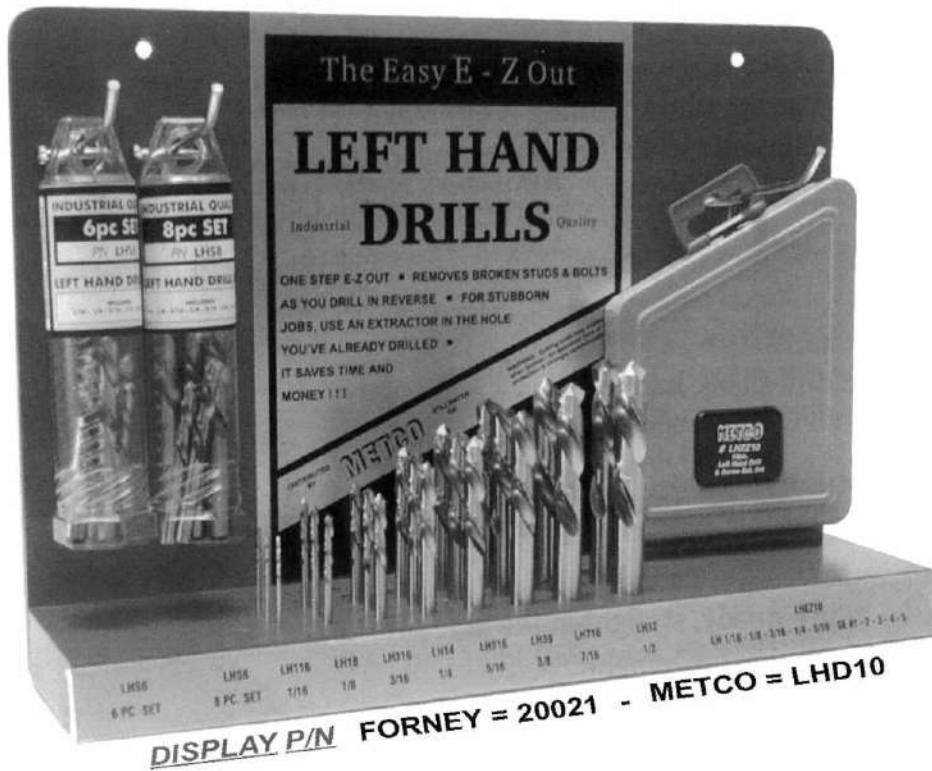

6 pc Set

FORNEY Cat#	METCO P/N
20510	Cat#
20481	LH116
20485	LH18
20489	LH316
20493	LH14
20497	LH516
20501	LH38

8 pc Set

FORNEY Cat#	METCO P/N
20511	Cat#
20481	LH116
20485	LH18
20489	LH316
20493	LH14
20497	LH516
20501	LH38
20505	LH716
20509	LH12

10 pc Set

FORNEY Cat#	METCO P/N
20512	LHEZ10
20481	20860 LH116 SE1
20485	20861 LH18 SE2
20489	20862 LH316 SE3
20493	20863 LH14 SE4
20497	20864 LH516 SE5

CONTENTS OF 20021 /LHD10 DISPLAY

QTY	FORNEY METCO		DESCRIPTION
	Cat#	Cat#	
3	20481	LH116	1/16 LEFT HAND DRILL
3	20485	LH18	1/8 LEFT HAND DRILL
3	20489	LH316	3/16 LEFT HAND DRILL
3	20493	LH14	1/4 LEFT HAND DRILL
2	20497	LH516	5/16 LEFT HAND DRILL
2	20501	LH38	3/8 LEFT HAND DRILL
1	20505	LH716	7/16 LEFT HAND DRILL
1	20509	LH12	1/2 LEFT HAND DRILL
1	20510	LHS6	6pc LEFT HAND DRILL SET
1	20511	LHS8	8pc LEFT HAND DRILL SET
1	20512	LHEZ10	10pc LH & EXTRACTOR SET



LEFT HAND DRILLS

LEFT HAND DRILLS

LEFT HAND SCREW MACHINE LENGTH DRILLS



The Eazy E-Z Out FRACTIONAL (STUBBY)

High Speed Steel, Bright Finish, 118° Point

Requires a reversing drill

"A great method of drilling out and removing broken studs, bolts and screws." Using a left hand drill bit for removal, eliminates tightening or spinning the work deeper. If a screw extractor is still necessary, try our tough extractors.

CAT# 20021



LEFT HAND DRILL ASSORTMENT 21 PC. (LHD10)

INCLUDES SETS: 20510, 20511, 20512

1EA: 7/16, 1/2,

2EA: 5/16, 3/8, 3 EA: 1/16, 1/8, 3/16, 1/4

INCLUDES DISPLAY



CAT# 20510

LEFT HAND DRILL SET 6 PC. (LHS6)

1EA: 1/16, 1/8, 3/16, 1/4, 5/16, 3/8



CAT# 20511

LEFT HAND DRILL SET 8 PC. (LHS8)

1EA: 1/16, 1/8, 3/16, 1/4, 5/16, 3/8, 7/16, 1/2



CAT# 20512 LEFT HAND DRILL & EXTRACTOR SET

10 PC. (LHEZ10) 1/16" - 5/16" by 64ths drills #1 - #5 extractors

CAT# 20513 LEFT HAND DRILL SET

29 PC. (LHS29) 1/16" - 1/2" by 64ths

CAT#	METCO#	DESCRIPTION	CAT#	METCO#	DESCRIPTION
20481	LH116	1/16 LEFT HAND DRILL	20496	LH1964	19/64 LEFT HAND DRILL
20482	LH564	5/64 LEFT HAND DRILL	20497	LH516	5/16 LEFT HAND DRILL
20483	LH332	3/32 LEFT HAND DRILL	20498	LH2164	21/64 LEFT HAND DRILL
20484	LH764	7/64 LEFT HAND DRILL	20499	LH1132	11/32 LEFT HAND DRILL
20485	LH18	1/8 LEFT HAND DRILL	20500	LH2364	23/64 LEFT HAND DRILL
20486	LH964	9/64 LEFT HAND DRILL	20501	LH38	3/8 LEFT HAND DRILL
20487	LH532	5/32 LEFT HAND DRILL	20502	LH2564	25/64 LEFT HAND DRILL
20488	LH1164	11/64 LEFT HAND DRILL	20503	LH1332	13/32 LEFT HAND DRILL
20489	LH316	3/16 LEFT HAND DRILL	20504	LH2764	27/64 LEFT HAND DRILL
20490	LH1364	13/64 LEFT HAND DRILL	20505	LH716	7/16 LEFT HAND DRILL
20491	LH732	7/32 LEFT HAND DRILL	20506	LH2964	29/64 LEFT HAND DRILL
20492	LH1564	15/64 LEFT HAND DRILL	20507	LH1532	15/32 LEFT HAND DRILL
20493	LH14	1/4 LEFT HAND DRILL	20508	LH3164	31/64 LEFT HAND DRILL
20494	LH1764	17/64 LEFT HAND DRILL	20509	LH12	1/2 LEFT HAND DRILL
20495	LH932	9/32 LEFT HAND DRILL			

**Cutting & Cooling fluids make the job easier
and greatly increase the life of the drill.**

LEFT HAND DRILLS

SHANK DRILLS

1/2" SHANK SILVER & DEMMING (S&D) DRILLS

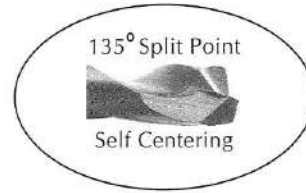

High Speed Steel, Surface Treated 135° Split Point Flatted Shank
 General purpose drills designed to fit 1/2" drill chucks. They are ideal for portable drilling of holes larger than 1/2" in diameter.

CAT# 20023	1/2" SHANK S&D DRILL ASSORTMENT 10 PC. (SADA10) 1 EA: 17/32", 9/16", 19/32", 5/8", 11/16", 3/4", 13/16", 7/8", 15/16", 1" INCLUDES PLANOGRAM
CAT# 20024	1/2" SHANK S&D DRILL ASSORTMENT 20 PC. (SADA20) 1 EA: 17/32", 9/16", 19/32", 5/8", 11/16", 3/4", 13/16", 7/8", 15/16", 1", 33/64", 35/64", 37/64", 21/32", 23/32", 25/32", 59/64", 1 1/16", 1 1/8", 1 1/4" INCLUDES PLANOGRAM
CAT# 20700	1/2" SHANK S&D DRILL SET METAL INDEX 5 PC. (SADS5) 9/16", 5/8", 11/16", 3/4", 1"
CAT# 20701	1/2" SHANK S&D DRILL SET METAL INDEX 8 PC. (SADS8) 13/16", 9/16", 5/8", 7/8", 11/16", 15/16", 3/4", 1"

ALL S&D DRILLS ARE 6" IN LENGTH

CAT#	METCO#	DESCRIPTION	CAT#	METCO#	DESCRIPTION
20657	SAD3364	33/64 1/2" SHANK DRILL	20679	SAD5564	55/64 1/2" SHANK DRILL
20658	SAD1732	17/32 1/2" SHANK DRILL	20680	SAD78	7/8 1/2" SHANK DRILL
20659	SAD3564	35/64 1/2" SHANK DRILL	20681	SAD5764	57/64 1/2" SHANK DRILL
20660	SAD916	9/16 1/2" SHANK DRILL	20682	SAD2932	29/32 1/2" SHANK DRILL
20661	SAD3764	37/64 1/2" SHANK DRILL	20683	SAD5964	59/64 1/2" SHANK DRILL
20662	SAD1932	19/32 1/2" SHANK DRILL	20684	SAD1516	15/16 1/2" SHANK DRILL
20663	SAD3964	39/64 1/2" SHANK DRILL	20685	SAD6164	61/64 1/2" SHANK DRILL
20664	SAD58	5/8 1/2" SHANK DRILL	20686	SAD3132	31/32 1/2" SHANK DRILL
20665	SAD4164	41/64 1/2" SHANK DRILL	20687	SAD6364	63/64 1/2" SHANK DRILL
20666	SAD2132	21/32 1/2" SHANK DRILL	20688	SAD1	1 1/2" SHANK DRILL
20667	SAD4364	43/64 1/2" SHANK DRILL	Following Drills are 118° Split Point		
20668	SAD1116	11/16 1/2" SHANK DRILL	20689	SAD1 132	1 1/32 1/2" SHANK DRILL
20669	SAD4564	45/64 1/2" SHANK DRILL	20690	SAD1 116	1 1/16 1/2" SHANK DRILL
20670	SAD2332	23/32 1/2" SHANK DRILL	20691	SAD1 332	1 3/32 1/2" SHANK DRILL
20671	SAD4764	47/64 1/2" SHANK DRILL	20692	SAD1 18	1 1/8 1/2" SHANK DRILL
20672	SAD34	3/4 1/2" SHANK DRILL	20693	SAD1 532	1 5/32 1/2" SHANK DRILL
20673	SAD4964	49/64 1/2" SHANK DRILL	20694	SAD1 316	1 3/16 1/2" SHANK DRILL
20674	SAD2532	25/32 1/2" SHANK DRILL	20695	SAD1 14	1 1/4 1/2" SHANK DRILL
20675	SAD5164	51/64 1/2" SHANK DRILL	20696	SAD1 516	1 5/16 1/2" SHANK DRILL
20676	SAD1316	13/16 1/2" SHANK DRILL	20697	SAD1 38	1 3/8 1/2" SHANK DRILL
20677	SAD5364	53/64 1/2" SHANK DRILL	20698	SAD1 716	1 7/16 1/2" SHANK DRILL
20678	SAD2732	27/32 1/2" SHANK DRILL	20699	SAD1 12	1 1/2 1/2" SHANK DRILL

**Cutting & Cooling fluids make the job easier
 and greatly increase the life of the drill.**

SHANK DRILLS

HOLE SAWS



Industrial Quality Bi-Metal COBALT ULTRA HSS Hole Saws



Features 8% COBALT HSS teeth treated to 64HRC • Thickened machined base for stability • Heat treated body for maximum resistance • 4/6 variable tooth pitch for aggressive cutting • 10° positive rake angle enhances cutting tough materials • Cuts mild to hardened steel, stainless steel, also most polymers, wood, plumbing and electrical fittings, etc.

20756 HSM3 7/16" SHANK
20758 HSM3R 3/8" SHANK
ARBOR MANDRELS
Fitted with a 20762 pilot drill - 2 drive lock pins

MAXIMUM CUTTING DEPTH
OF 13/8" OR 34 MM

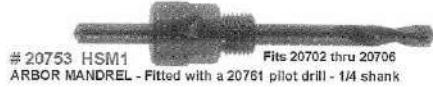

20753 HSM1 Fits 20702 thru 20706
ARBOR MANDREL - Fitted with a 20761 pilot drill - 1/4 shank



20755 HSM2R Fits 20702 thru 20706
ARBOR MANDREL - Fitted with 20762 pilot drill - 3/8 shank

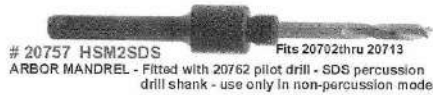

20757 HSM2SDS Fits 20702 thru 20713
ARBOR MANDREL - Fitted with 20762 pilot drill - SDS percussion drill shank - use only in non-percussion mode



20759 HSM3SDS Fits 20714 thru 20752
ARBOR MANDREL
Fitted with 20762 pilot drill - SDS percussion drill shank
2 drive lock pins - use only in non-percussion mode

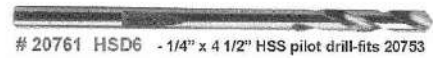

20761 HSD6 - 1/4" x 4 1/2" HSS pilot drill-fits 20753

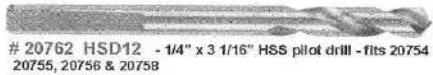

20762 HSD12 - 1/4" x 3 1/16" HSS pilot drill - fits 20754, 20755, 20756 & 20758



20763
Ejector Spring

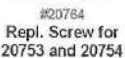

#20764
Repl. Screw for 20753 and 20754

20760 - Bushing to increase thread size on 20753 & 20755 arbor mandrels to fit larger hole sizes. (NOT RECOMMENDED FOR USE ON HOLE SAWS LARGER THAN 1 3/4")

20765
Repl. Screw for 20756 & 20758



20773 HSEX12 - 12" Extension Bar - 7/16" Shank Fits 20754, 20756 & 20758 Arbor Mandrels



HOLE SAW SETS

RECOMMENDED CUTTING SPEEDS (RPM)

SIZE	FOR MILD STEEL	SIZE	FOR MILD STEEL	FOR OTHER MATERIALS
9/16	580	2-1/4	150	Stainless and Tool Steel Reduce RPM'S by 50%
5/8	550	2-5/16	155	
11/16	500	2-3/8	140	
3/4	460	2-1/2	135	
13/16	425	2-9/16	130	
7/8	390	2-5/8	130	Cast Iron Reduce RPM'S by 33%
15/16	370	2-3/4	125	
1	350	2-7/8	120	
1-1/16	325	3	115	Aluminum Increase RPM'S by 50%
1-1/8	300	3-1/8	110	
1-3/16	285	3-1/4	105	
1-1/4	275	3-3/8	100	
1-5/16	260	3-1/2	95	
1-3/8	250	3-5/8	95	Brass Increase RPM'S by 33%
1-7/16	240	3-3/4	90	
1-1/2	230	3-7/8	90	
1-9/16	220	4	80	Wood and Most Plastics 800+ RPM'S Experiment for best rpm!
1-5/8	210	4 1/8	75	
1-11/16	205	4 1/4	75	
1-3/4	195	4 3/8	70	
1-13/16	190	4 1/2	70	
1-7/8	180	4 3/4	65	
2	170	5	60	
2 1/16	165	5-1/2	55	
2 1/8	160	6	50	

20766 HSELSET - 6 Piece Electricians Hole Saw Set - Includes 1 each: 20707, 20712, 20716, 20722, 20725, 20732; 20754, 20756 MANDRELS; 20762 REPLACEMENT PILOT DRILL; 20763 EJECTOR SPRING

20767 HSUTSET - 6 Piece Utility Hole Saw Set - Includes 1 each: 20703, 20706, 20709, 20714, 20719, 20725; 20754, 20756 MANDRELS; 20762 REPLACEMENT PILOT DRILL; 20763 EJECTOR SPRING

20768 HSPLSET - 9 Piece Plumbers Hole Saw Set Includes - 1 each: 20705, 20707, 20712, 20716, 20718, 20722, 20725, 20728, 20732; 20754, 20756 MANDRELS; 20762 REPLACEMENT PILOT DRILL; 20763 EJECTOR SPRING.

HOLE SAWS

HOLE SAWS, BI-METAL COBALT HIGH SPEED STEEL

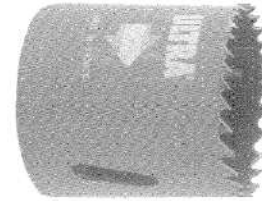
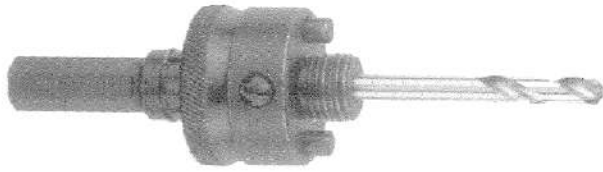

CAT# 20025 HOLE SAW ASSORTMENT 35 PC. (HSA32)

1 EA: 5/8", 3/4", 7/8", 1", 1 1/8", 1 1/4", 1 3/8", 1 1/2", 1 5/8", 1 3/4", 1 7/8", 2", 2 1/8", 2 1/4", 2 1/2", 2 9/16", 2 3/4", 3", 3 1/8", 3 1/4", 3 1/2", 3 3/4", 4", 4 1/4", 20753, 20755, 20761, 20762, 20763, 20764, 20765, (2) 20756, (2) 20758. INCLUDES DISPLAY

CAT#	METCO#	DESCRIPTION	CAT#	METCO#	DESCRIPTION
20702	HS916	9/16 BI-METAL HOLE SAW	20727	HS2 18	2 1/8 BI-METAL HOLE SAW
20703	HS58	5/8 BI-METAL HOLE SAW	20728	HS2 14	2 1/4 BI-METAL HOLE SAW
20704	HS1116	11/16 BI-METAL HOLE SAW	20729	HS2 516	2 5/16 BI-METAL HOLE SAW
20705	HS34	3/4 BI-METAL HOLE SAW	20730	HS2 38	2 3/8 BI-METAL HOLE SAW
20706	HS1316	13/16 BI-METAL HOLE SAW	20731	HS2 12	2 1/2 BI-METAL HOLE SAW
20707	HS78	7/8 BI-METAL HOLE SAW	20732	HS2 916	2 9/16 BI-METAL HOLE SAW
20708	HS1516	15/16 BI-METAL HOLE SAW	20733	HS2 58	2 5/8 BI-METAL HOLE SAW
20709	HS1	1 BI-METAL HOLE SAW	20734	HS2 34	2 3/4 BI-METAL HOLE SAW
20710	HS1 116	1 1/16 BI-METAL HOLE SAW	20735	HS2 78	2 7/8 BI-METAL HOLE SAW
20711	HS1 332	1 3/32 BI-METAL HOLE SAW	20736	HS3	3 BI-METAL HOLE SAW
20712	HS1 18	1 1/8 BI-METAL HOLE SAW	20737	HS3 18	3 1/8 BI-METAL HOLE SAW
20713	HS1 316	1 3/16 BI-METAL HOLE SAW	20738	HS3 14	3 1/4 BI-METAL HOLE SAW
20702 thru 20713 use mandrel 20753, 20755, 20757			20739	HS3 38	3 3/8 BI-METAL HOLE SAW
20714	HS1 14	1 1/4 BI-METAL HOLE SAW	20740	HS3 12	3 1/2 BI-METAL HOLE SAW
20715	HS1 516	1 5/16 BI-METAL HOLE SAW	20741	HS3 58	3 5/8 BI-METAL HOLE SAW
20716	HS1 38	1 3/8 BI-METAL HOLE SAW	20742	HS3 34	3 3/4 BI-METAL HOLE SAW
20717	HS1 716	1 7/16 BI-METAL HOLE SAW	20743	HS3 78	3 7/8 BI-METAL HOLE SAW
20718	HS1 12	1 1/2 BI-METAL HOLE SAW	20744	HS4	4 BI-METAL HOLE SAW
20719	HS1 916	1 9/16 BI-METAL HOLE SAW	20745	HS4 18	4 1/8 BI-METAL HOLE SAW
20720	HS1 58	1 5/8 BI-METAL HOLE SAW	20746	HS4 14	4 1/4 BI-METAL HOLE SAW
20721	HS1 1116	1 11/16 BI-METAL HOLE SAW	20747	HS4 38	4 3/8 BI-METAL HOLE SAW
20722	HS1 34	1 3/4 BI-METAL HOLE SAW	20748	HS4 12	4 1/2 BI-METAL HOLE SAW
20723	HS1 1316	1 13/16 BI-METAL HOLE SAW	20749	HS4 34	4 3/4 BI-METAL HOLE SAW
20724	HS1 78	1 7/8 BI-METAL HOLE SAW	20750	HS5	5 BI-METAL HOLE SAW
20725	HS2	2 BI-METAL HOLE SAW	20751	HS5 12	5 1/2 BI-METAL HOLE SAW
20726	HS2 116	2 1/16 BI-METAL HOLE SAW	20752	HS6	6 BI-METAL HOLE SAW
			20714 thru 20752 use mandrel 20756, 20758, 20759		

**Cutting & Cooling fluids make the job easier
and greatly increase the life of the holesaw.**

WARNING: FAILURE TO HEED SAFETY INSTRUCTIONS CAN RESULT IN SERIOUS BODILY INJURY: ALWAYS WEAR PROPER CERTIFIED FACE & BODY PROTECTION WHEN USING THESE TYPES OF TOOLS OR IN THE CLOSE PROXIMITY OF TOOL USE!

HOLE SAWS

HOLE SAW SETS, MANDRELS AND ACCESSORIES

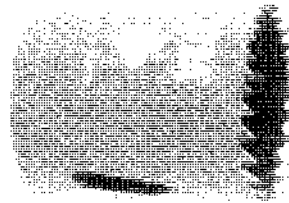

CAT#	METCO#	DESCRIPTION	CAT#	METCO#	DESCRIPTION
20753	HSM1	1/4 ARBOR MANDREL FOR 9/16"- 1 3/16" HOLE SAWS Fits 20702 thru 20713. Fitted with a 20761 pilot drill - 1/4 shank.	20760	HSBUSH	FOR 20753 20755 Bushing to increase thread size on 20753 & 20755 arbor mandrels to fit larger hole sizes. (NOT RECOMMENDED FOR USE ON HOLE SAWS LARGER THAN 1 3/4").
20754	HSM2	DISCONTINUED USE 20755	20761	HSD6	#6 PILOT DRILL FOR #1 MANDREL 1/4" x 4 1/2" HSS PILOT DRILL - FITS 20753
20755	HSM2R	3/8" ARBOR MANDREL FOR 9/16"- 1 3/16" HOLE SAWS Fits 20702 thru 20713 Fitted with 20762 pilot drill - 3/8" shank	20762	HSD12	#12 PILOT DRILL FOR #2-3 MANDREL 1/4" x 3 1/16" HSS pilot drill - Fits 20753, 20755, 20756, 20757, 20758, 20759
20756	HSM3	7/16" ARBOR MANDREL FOR 1 1/4" to 6" HOLE SAWS Fits 20714 - 20752 Fitted with a 20762 pilot drill - 2 drive lock pins. (7/16" SHANK).	20763	HSSPRING	HOLE SAW EJECTOR SPRING
20757	HSM2SDS	SDS SHANK HOLE SAW MANDREL Fits 20702-20713. Fitted with 20762 pilot drill - SDS percussion drill shank - use only in non-percussion mode.	20764	HSSCREW1	REPLACEMENT SCREW for 20753, 20755, & 20757
20758	HSM3R	3/8" ARBOR MANDREL FOR 1 1/4"-6" HOLE SAWS Fits 20714-20752. Arbor Mandrels - Fitted with a 20762 pilot drill - 2 drive lock pins (3/8" SHANK).	20765	HSSCREW2	REPLACEMENT SCREW for 20756, 20758, 20759
20759	HSM3SDS	SDS SHANK HOLE SAW MANDREL Fits 20714 - 20752. Fitted with 20762 pilot drill - SDS percussion drill shank. 2 drive lock pins - use only in non-percussion mode.	20773	HSEX12	EXTENSION BAR 12" Extension Bar - 7/16" Shank fits 20756, Arbor Mandrels

**NOTE: SDS = Single Double Slotted
For Percussion Hammer Drills**

HOLE SAW SETS BI-METAL COBALT & HSS

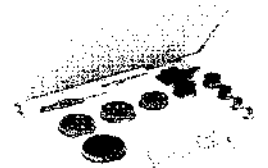

CAT# 20766 (HSELSET)

6 Piece Electricians Hole Saw Set - Includes 1 each: 20707, 20712, 20716, 20722, 20725, 20732 Hole Saws; 20755, 20756 Mandrels; 20762 Replacement Pilot Drill; 20763 Ejector Spring. 7/8", 1 1/8", 1 3/8", 1 3/4", 2", 2 9/16"

CAT# 20767 (HSUTSET)

6 Piece Utility Hole Saw Set - Includes 1 each: 20703, 20706, 20709, 20714, 20719, 20725 Hole Saws; 20753, 20756 Mandrels;; 20761 Replacement Pilot Drill; 20763 Hole Saw Ejector Spring. 5/8", 1 3/16", 1", 1 1/4", 1 9/16", 2"

CAT# 20768 (HSPLSET)

9 Piece Plumbers Hole Saw Set - Includes 1 each: 20705, 20707, 20712, 20716, 20718, 20722, 20725, 20728, 20732 Hole Saws; 20755, 20756 Mandrels; 20762 Replacement Pilot Drill; 20763 Ejector Spring. 3/4", 7/8", 1 1/8", 1 3/8", 1 1/2", 1 3/4", 2", 2 1/4", 2 9/16"

SCREW EXTRACTOR

SUPER TOUGH INDUSTRIAL QUALITY E-Z OUTS

HELICAL FLUTED SCREW EXTRACTORS

For removing broken screws, bolts, threaded pipe sections and other threaded parts. The extractor is inserted into a pre-drilled hole and the broken part is backed out with the use of a wrench.



TECHNICALLY CORRECT IN THE TAPER - SPIRAL - METALURGY

The display chart shows the drill size: Fractional and metric

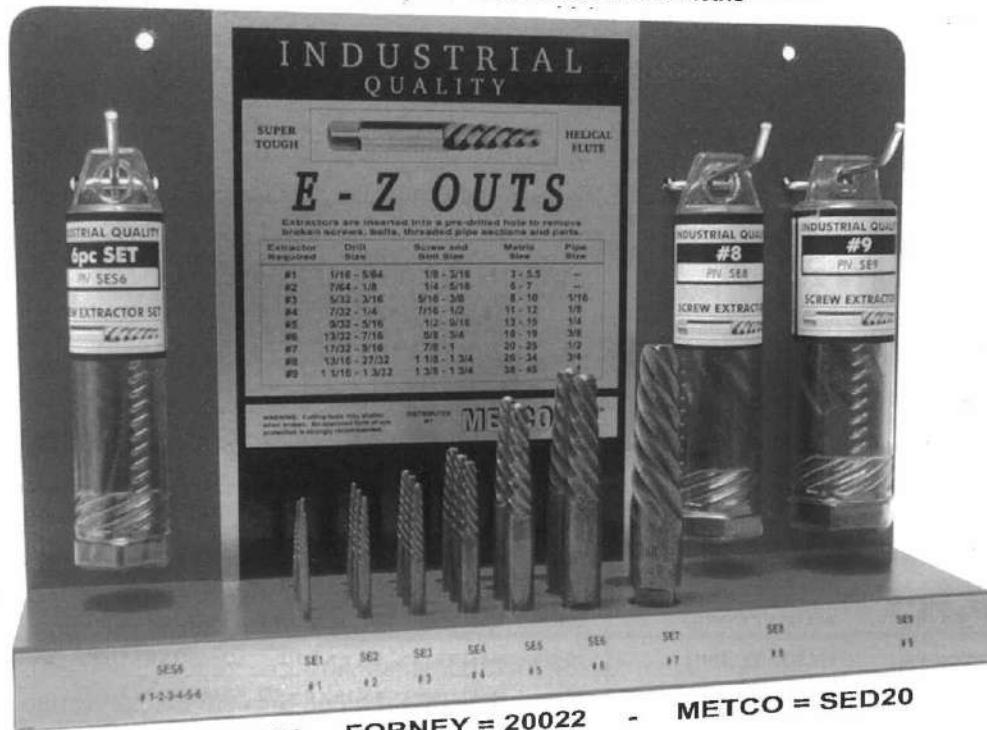

6 pc. SET

FORNEY P/N	METCO P/N
20022	SES6
20860	SE1
20861	SE2
20862	SE3
20863	SE4
20864	SE5
20865	SE6

DISPLAY P/N FORNEY = 20022 - METCO = SED20

CONTENTS OF "E-Z OUTS" DISPLAY

ALSO AVAILABLE
#10 - #11 - #12
SCREW EXTRACTORS
(20869, 20870, 20871)

QTY	FORNEY P/N	METCO P/N	DESCRIPTION
3	20860	SE1	#1 HELICAL FLUTED EXTRACTOR
3	20861	SE2	#2 HELICAL FLUTED EXTRACTOR
3	20862	SE3	#3 HELICAL FLUTED EXTRACTOR
3	20863	SE4	#4 HELICAL FLUTED EXTRACTOR
2	20864	SE5	#5 HELICAL FLUTED EXTRACTOR
2	20865	SE6	#6 HELICAL FLUTED EXTRACTOR
1	20866	SE7	#7 HELICAL FLUTED EXTRACTOR
1	20867	SE8	#8 HELICAL FLUTED EXTRACTOR
1	20868	SE9	#9 HELICAL FLUTED EXTRACTOR
1	20872	SES6	6 pc EXTRACTOR SET

The #7,8 & 9 extractors are most commonly used for pipe extraction

SUPER TOUGH

SCREW EXTRACTOR

SCREW EXTRACTOR & STUBBY DRILL

HELICAL FLUTE SCREW EXTRACTORS

SUPER TOUGH E-Z OUTS



See page 11 & 12 for Left Hand Drills & Extractor Sets)

For removing broken screws, bolts, and threaded parts. The extractor is inserted into a predrilled hole and the broken part is backed out with a wrench. Also for turning threaded pipe sections.



CAT# 20022 SCREW EXTRACTOR DISPLAY SED20



INCLUDES SET: 20872

1EA: #7, #8, #9

2EA: #5, #6

3EA: #1, #2, #3, #4

INCLUDES DISPLAY

CAT# 20872 SCREW EXTRACTOR SET 1EA., #1-#6 (SES6)

(Also available #10, #11, #12)

CAT#	METCO#	DESCRIPTION
20860	SE1	#1 SPIRAL SCREW EXTRACTOR
20861	SE2	#2 SPIRAL SCREW EXTRACTOR
20862	SE3	#3 SPIRAL SCREW EXTRACTOR
20863	SE4	#4 SPIRAL SCREW EXTRACTOR
20864	SE5	#5 SPIRAL SCREW EXTRACTOR
20865	SE6	#6 SPIRAL SCREW EXTRACTOR

CAT#	METCO#	DESCRIPTION
20866	SE7	#7 SPIRAL SCREW EXTRACTOR
20867	SE8	#8 SPIRAL SCREW EXTRACTOR
20868	SE9	#9 SPIRAL SCREW EXTRACTOR
20869	SE10	#10 SPIRAL SCREW EXTRACTOR
20870	SE11	#11 SPIRAL SCREW EXTRACTOR
20871	SE12	#12 SPIRAL SCREW EXTRACTOR

Cutting & Cooling fluids make the job easier
and greatly increase the life of the drill.

DOUBLE END BODY DRILLS

FRACTIONAL

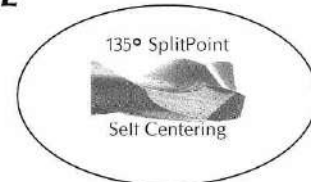

High Speed Steel, Bright Finish, 135° Split Point
Special purpose short drills for use in sheet metal,
auto body work, etc.

DOUBLE END STUBBY DRILLS

CAT#	METCO#	DESCRIPTION
20555	DED18	1/8 DOUBLE END DRILL

CAT#	METCO#	DESCRIPTION
20558	DED316	3/16 DOUBLE END DRILL

Cutting & Cooling fluids make the job easier
and greatly increase the life of the drill.

SCREW EXTRACTOR & STUBBY DRILL

HIGH SPEED HACKSAW

THE ULTRA HIGH TECH BLADE ULTRA HARD-ULTRA FLEXIBLE-ULTRA SAFE

COBALT HIGH SPEED STEEL HACKSAW BLADE

Cobalt high speed steel hacksaw blades are an innovation in hand hacksaw blades. Until recently, cobalt high speed steel has been used only in the production of cutting tools, such as milling cutters, taps, dies, etc. Hand hacksaw blades of cobalt high speed steel have the hardness and heat resistance required to retain their cutting edge much longer than bi-metal blades. The cobalt blade combines extreme tooth hardness with a more flexible body through a unique staged heat treatment.

STAGED HARDNESS

The hardening operation is accomplished through a highly technical process, monitored by a microprocessor. This process controls all parameters and allows the correct hardness to be achieved in each of these 4 areas:

AREA 1: Tooth Hardness - 65RC - This hardness is the maximum that can be reached using a cobalt high speed steel.

AREA 2: Gullet Hardness - 32RC - The hardness of this area has been reduced specifically to avoid shearing of the teeth.

AREA 3: Body Hardness - 42RC - This medium hardness maintains flexibility and avoids permanent distortion.

AREA 4: Back Edge Hardness - 50RC - Gives both life and rigidity.

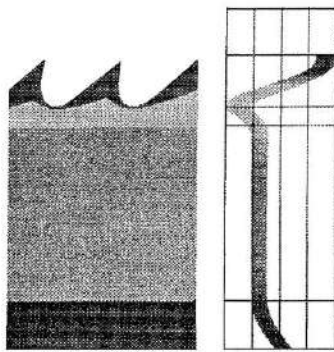

This staged heat treatment enables the blade to attain a functional hardness for each area and avoids the problem of the welding line associated with bi-metal blades.

TOOTH SETTING

Both the 18-tooth and the 24-tooth blades feature a RAKER SETTING alternate set, which is far more efficient than the wavy design found on conventional blades. This type of tooth set is more suitable in a wider range of applications because it avoids pinching at the side of the blade. This is a big advantage over wavy set blades.

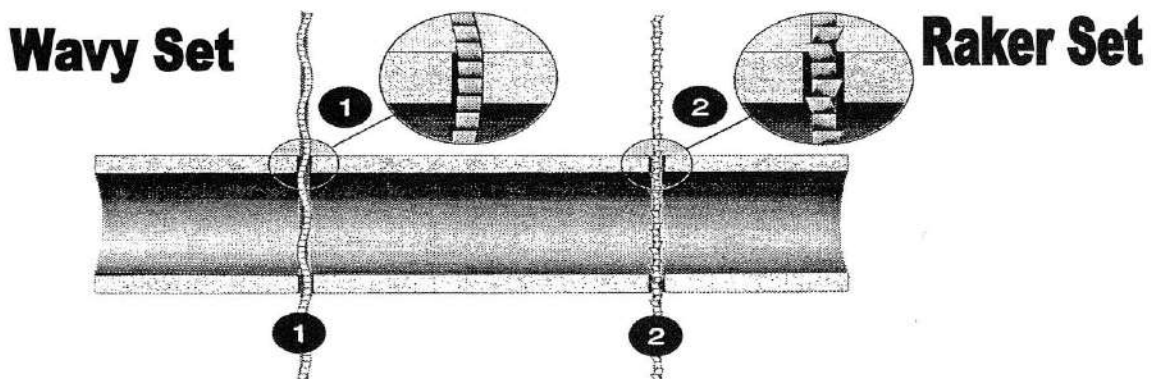

HACKSAW BLADES

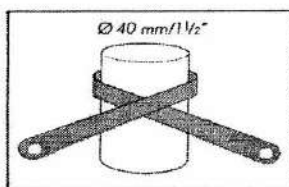

1) Flexible
Ultra bi-hard blade can bend like a bi-metal blade.

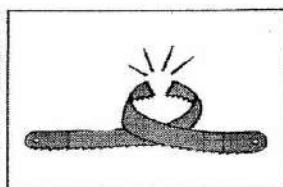

2) Shatterproof
Extremely bending the blade it will have a clean break, and will not shatter.

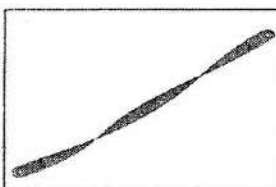

3) Supple
Twist the Ultra bi-hard blade at 360 Degrees and have no breakage.

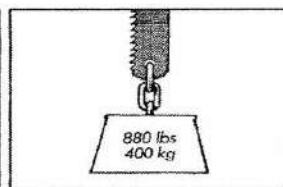

4) Strength
Ultra bi-hard blade can hold a load of 400 kg/880 lbs with no distortion.

HACKSAWS

12" BI - HARD COBALT HACKSAW BLADES

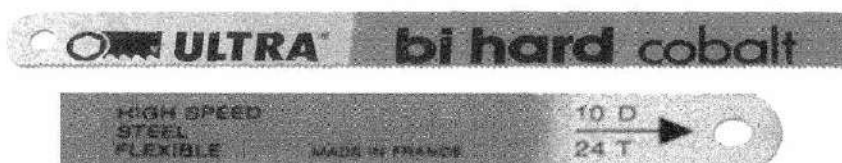

CAT# 20032

HACKSAW BLADE ASSORTMENT (BCOD)

10 EA 21278 & 21280; 20 EA 21279; 2 EA 21277; INCLUDES DISPLAY

CAT#	METCO#	DESCRIPTION
21278	BCO18T	COBALT FLEX BLADE (RAKER SET)
21279	BCO24T	COBALT FLEX BLADE (RAKER SET)
21280	BCO32T	COBALT FLEX BLADE (WAVY SET)

Sold in Multiples of 10

12" ULTRA FLEX HACKSAW BLADES



Alloy steel, wavy set, for cutting of softer materials.

CAT# 20033

FLEX HACKSAW BLADE ASSORTMENT (BUFD)

10 EA 21281 & 21283; 20 EA 21282; INCLUDES DISPLAY

CAT#	METCO#	DESCRIPTION
21281	BUF18T	ULTRA FLEX BLADE (WAVY SET)
21282	BUF24T	ULTRA FLEX BLADE (WAVY SET)
21283	BUF32T	ULTRA FLEX BLADE (WAVY SET)

Sold in Multiples of 10

INDEX

- A -

Abrasives	
Aluminum Type 27	58
Asphalt	59
Bench Grinder	61
Blue Zirconia Flap Discs	60
Carbide Burs	75
Circular Wire Wheels	73
Concrete	59
Cup Brushes	68 & 71
Cut-Off Wheels (Metal)	59 & 63
Emery Cloth / Sand Screen	62
End Brushes	70 & 74
Flap Wheels	67
Hubless (Type 27)	58
Masonry Cut-Off Wheels	59
Micro Abrasives	76
Mounted Grinding Point	74 & 75
Mounted Grinding Wheels, w/Mandrel & Screw	74 & 75
Packaged Wire Wheels & Cup Brushes	68 & 69
Rotary File & Wood Rasps	75
Safety Information	64
Sand Discs	62 & 76
Stainless Steel Brushes	39 - 41
Threaded Hub (Type 27 & 28)	58
1/4" Shank Wire Cup & End Brushes for Power Drills	69 & 70
Acetylene Welding Rod	9
Adapters	
Reducer	61
Regulator to Tank	25
Side Terminal	103
Air Chuck	97
Air Compressor Repair Parts	
Air / Water Adapter	96
Cast Brass Check Valve	95
Hose Repair Kit	96
Mini Filter, Mini Regulator, Mini Lubricator	95 - 97
Pressure Gauge/Switches	96
Safety Valves	95
Tank Valve, Tank Manifolds, 3-in-1 Manifold	95 & 96
Air Filters	95
Air Fittings & Accessories	87 - 100
Air Hose (PVC & Poly-Flex)	2 & 99
Airline Swivels	93
Aluminum Alloy Mig Wire	12
Aluminum (Welding & Brazing)	
Brazing Rod	7
Electrodes	7
Anti Spatter	11
ARO Design (Air Fittings)	89
Auto Darkening Helmets	78 & 79

- B -

Battery	
Clamps	104
Terminals	102 & 103
Binzel Spot Weld Nozzle	3
Bits, Screwdriver	47 & 48
Blades - Hack Saws	47
Blow Guns	94
Brass Fittings (Air)	92 & 93
Brass Cross / Tee	95
Brass Safety Valves	95
Brazing	
Carbons	21
Rod	9
Brushes	
Brass Wire, V-Groove	40
Chipping Hammer Replacement	38

Circular Brush	68 - 74
End	70 & 74
Flux Soldering	15
Long Handle	39 & 40
Parts Cleaning	41 & 42
Shoe Handle	39
Stainless Steel	39 & 40
Stringer Bead Wire	73
Tube	41
Wire Brush Display	43
Wire Handle	41
Buffing Wheel	66
Bumper Plate Kit	19
Burs - Carbide	75
Butt Connectors	20

- C -

Cable	
Jumper	100
Lug / Butt Connectors	20
Output Jacks & Plugs	19
Receptacles - Portable & Wall	21
Splicers	19
Welding - Bulk	18
Carbide Burs	75
Cast Rod	7 & 8
Chainsaw Files	49 & 50
Charger Clamps	104 & 105
Check Valve	95
Chipping Hammers	38
Chuck, Dual Foot	97
Clamps	
Chain	46
C-Clamp - Locking Plier Style	46
C-Clamp - Malleable Iron	46
Oetiker	36
Cleaner Kit	
Long Tip	22
Standard Tip	22
Cobalt Bi-Metal Reciprocating Saw Blade	13
Connectors (Electrical)	117
Contact Tips	4
Couplers	23 - 25, 88 & 89
Crimping Tool	25
Crimped Wire Brush	70 & 74
Cup Brushes	70 & 71
Cut-Off Wheel Kit	59
Cutting & Cooling Fluids	121
Cutting Attachments	30 - 33
Cutting Tip Cross Reference Chart	36
Cutting Tips	
Oxy-Acetylene / Propane	27 & 28, 35 & 37

- D -

Detergent (Pressure Washer)	113
Discharge Hose for Sludge Pump	113
Discs	
Abrasive	59 - 63
Diamond Cutting Blades	65
Sanding	62 & 76
Trim Cut	66
Drills	
Cobalt	118
Jobber	119
Left-Hand Drill	122 & 123
Shank	124
Drilling & Cutting Tips	120
Drill Sets	22
Dust Masks	85

- E -

Ear Plugs	
Disposable	85
Muffs	85
Reusable	85
Electrical Connectors & Plugs	117

Electrical Test Clips	105
Electrode Holders	16
Electrodes & Rods	
Acetylene	9
Arc	7 - 9
Aluminum	9
Brazing	9
Cast	8
Hard Surfacing	7
Mild Steel	5 & 6
Nickel	8
Stainless Steel	9
Emery Cloth / Sand Screen	61
Engineer's Opening File Inventory	50
Extension Cords	117
Eye Bolt, Screw Hook & Screw Eye Centre	55

- F -

Face Shield - Grinding	
Replacement Shield and Headband	83
Ferrules for Oxy-Acetylene Hose	23
Files & Accessories	49 & 50
Filters - Air	95
Flashback Arrestor	24
Flat Insert Bits	48
Flex Magnet	45
Flint Lighters	22
Renewals	22
Flux	
Brazing Rod	9
Brush - Bulk / Skin-Packed	15
Liquid	15
Fuse - Multi Tester	21

- G -

Galvanizing Compound	11
Gas	
Argon Regulator Kit	3
Line Adapter	3
Gas Cylinders - Oxy-Acetylene, Argon, CO ₂	26
Gauge	
Oxy-Acetylene	26
Pressure	26 & 95
Tire	100
Glasses - Safety	84
Gloves	86
Glove	
J-B Weld	15
Speedybond for Metal	15
Speedybond for Plastic	15
Goggles - Oxy-Acetylene	82
Grab Hooks	51
Grinding	
Bench	61
Disc, Abrasive	62 - 66
Wheel Dresser & Parts	61
Ground Clamps - Steel & Brass	17
Ground Clamps - Magswitch	114

- H -

Hacksaw Blades	47
Hacksaw Frames	47
Hacksaw Blades Cobalt High Speed	130 & 131
Hammers, Chipping	38
Hardfacing Electrodes & Rod	7
Harris Style Tips	35
Hard Hats, Deluxe	80
Headgear	80
Hearing Muffs	85
Heating Tips	
Rosebud / Oxy-Acetylene	27, 28 & 35
Helmets	77 - 79
Lens	81
Welding	77 - 79
Holders (Electrode)	16
Holesaws (Bi-Metal)	125 - 127

INDEX

Arbor Mandrels	125
Hook Centre	52
Hose / Air	
Adapters	92
Couplers	88 - 91
Coupler Test Bar	92
Fittings	85 - 94
Polyflex	2
Recoil	99
Splicers	2 & 92
Hose - Oxy-Acetylene	
Braces	23
Check Valves	24
Connectors	24
Couplers	23
Ferrules	23
Nipples	23
Nuts	23 & 24
Oxy-Acetylene Fittings	23 - 25
Repair Kit	25
Repair Parts	23 - 25
Regulator Fittings	24
- I -	
Insert Bits	47 & 48
Industrial Milton (Air Fittings)	88
- J -	
Jacks, Welder Repair	19
J-B Weld	15
Jumper Cables	101 & 102
Bumper Plate	19
- K -	
Knotted Wire Brushes	71
Knotted Wire Wheels	70
- L -	
Lead Free Solder	10
Lens	
Acetylene - Welding	77 - 79
Helmet - Welding	77 - 79
Lincoln Air Fittings	91
Liners	
Wire	3
Mig	3
Linking Centre	53
Locking Plier - C-Clamp, Welding	46
Lubricators	95 - 97
Lug Tray	20
Lugs - Cable - Bulk/Skin-Packed	20
- M -	
Machinist File Opening Inventory	50
Magnetic Level	43
Magnetic Scribe	45
Magnetic Nut Setters	48
Magnetizer-Demagnetizer	121
Magnets	46
Manifold (Tank)	95
Mandrel	59
Marker, Cold Surface (Yellow)	44
Marking Pencil	45
Soapstone and Refills	45
Thin Line and Refills	45
Masks, Dust	85
Masonry Cut-Off Wheels	59
Mig Gun Replacement Parts, Nozzle,	
Contact Tips, Mig Pliers	3 & 4
Mig Pliers	4
Mig Wire	12
Mixer Assemblies	28, 30, 32, 33 & 35
Mounted Flap Wheels	67
Mounted Grinding Wheels	
Skin-Packed & Tray	74
Mounted Points	
Skin-Packed & Tray	74
Multi-Purpose Magnets	46

Multi-Testers	21
- N -	
Nickel Welding Rod	8
Nipples	23 & 25
Nozzles	
Binzel Nozzles	3
Rosebud Heating	27, 28 & 35
Tweco Nozzles	3
Welding - Brazing	27 & 35
Nozzle Gel	11
- O -	
Oetiker Clamps	36
O-Ring Kit (15 pieces)	113
Oxy-Acetylene / Propane	
Couplers	23
Gauges	26
Goggles	81 - 83
Hose Couplers	23
Hose & Repair Parts	23
Lens	81
Lighters & Renewals	22
Mixer Assemblies	28, 30, 32, 33 & 35
Regulators	30 - 33
Reverse Flow Check Valves	24
Rosebud Heating	27, 28 & 35
Tips - Cutting	27 & 28
- P -	
Paint Markers	1 & 44
Panel Cutter Cut-Off Wheels	59
Pick Repair Kit (4-Way)	44
Plastic Welder	1
Pliers (Mig)	4
Plugs	
Connector	117
Ear	85
Power Pintype & Crowfoot	21
Sure Grip - Male & Female	19
Plumbers Torch Kit / Accessories	23
Polishing Bonnets	66
Pressure Gauges	
Oxy-Acetylene - High / Low	26
Pressure Gauges, Switches (Air)	95
Pressure Washer Accessories	109 - 113
Pro Flame Oxy-Acetylene Torch Kit	33
Propane Tips - Oxy-Acetylene	35 & 36
- Q -	
Quick Link (Galvanized)	51
- R -	
Receptacle, Power - Portable, Wall	21
Reciprocating Saw Blades	13
Recoil Air Hose	99
Reducer Adapter	92 & 93
Reducing Bushings	61
Regulators	
Acetylene	30 - 33
Argon, Air	3
Oxygen	30 - 33
Repair Kits - Oxy-Acetylene	25
Repair Links	51
Respirators	85
Rod	
Acetylene	9
Aluminum	9
Brazing	9
Cast	8
Hardfacing	7
Low Hydrogen	5
Mild Steel	10
Specialty	7
Stainless Steel	7
Rosin Core Solder	10
Rotary Files, Cutters, Rasps	75 & 76

- S -	
Safety Equipment	
Dust Masks	85
Glasses	84
Gloves	86
Goggles	82
Grinding Shields and Parts	83
Headgear, Ratchet	80
Helmets	77 - 79
Lens	81
Respirators	85
Safety Glasses	84
Safety Information	
(Wire Brushes & Grinding Wheels)	64
Sanding Discs	62 & 76
Saw Blades	13
Screwdriver Bits	47 & 48
Screw Extractor	128 & 129
Scribe & Replacement Tips	44
Scribe & Magnetic Top	45
Self-Shielding Mig Wire	12
Shackles, Swivels & Clevis Centre	53
Shop Flame Heavy Duty Torch Kit	31
Shop Flame Torch Kit II	30
Shop Tools	38 - 48
Shuts	51
Sludge Pump	113
Small Slip and Grab Hooks	56
Snap Hook Centre	56
Soapstone - Holders & Refills	45
Solder	
Acid Core	10
Lead Free	10
Rosin Core	10
Soft Silver Solder Kit	14
Solid Wire	10
Soldering Iron	14
Spanner Wrench	62
Specialty Electrodes	
Arc	7
Hard Surfacing	7
Speedybond	15
Splicer for Flex Hose	2
Spotweld Nozzle	3
Springs	
Extension & Compression	106 - 108
Wall Display	115
Stainless Steel Mig Wire	12
Stainless Steel Welding Rod	9
Stainless Steel Wire Brushes	39 & 40
Storage Containers	
Rod / Polypropylene	14
Strain Relief for Flex Hose	2
Strikers (Single & Triple)	22
Stringer Bead Twist	73
Stubby Drill	129
- T -	
Tanks	
Acetylene	26
Argon ²	26
Oxygen	26
Tank Valve	95
Terminals - Battery	103
Terminal Lugs	20
Thimbles	51
Tiger Torch	34
Tips	
Cleaner	22
Cutting	27 & 28, 35 & 37
Drills and Replacements	22
Airco	37
Harris	35
Purox	37
Smith	37

INDEX

Victor Journeyman Style	28	Turnbuckle Centre	57	Nickel	8
Victor Style	27	Tweco Nozzle	3	Wheels	
Tip Drill Set	22	Tweco Gas Diffuser	3	Abrasive	58 & 59
Tire Gauges	100			Cut-Off	63
Tire Valve Repair Tools	98			Grinding	58 - 63
Torch Handles	30 - 33			Wire Liner for Torch Neck	3
Victor	30 & 31			Wire Rope Clips	51
Torch Kits				Wrenches	
Plumber's Torch (1720)	34			Cylinder	26
Pro Flame (1680)	32			Spanner	62
Pro Flame (1687)	33				
Shop Flame Heavy-Duty (1711)	31				
Shop Flame II (1705)	30				
Tiger Torch (95-B)	34				
Tote-A-Torch Portable (1753)	29				
Uni-Flame Burner (1723)	34				
Victor Shop Flame (1705)	30				
Torch Neck w/Gas Diffuser	3				
Torch Nozzle	3				
Trim Kut	66				
Triple Tap Extension Cords	115				
Tru-Flate Design (Air Fittings)	89				

- U -

- V -

- W -

NUMERICAL INDEX

00146	102	21278-21283	131	55193, 55194, 55196-55198	86
00533-00536	102	21305	121	55200, 55202, 55203, 55259	86
00862	102	21313	121	55275, 55285, 55295, 55299	84
95-B	34	30305, 30410, 30510	5	55301, 55302, 55304	82
222	115	30681, 30686, 30690	6	55310, 55311, 55320	82
1680	32	30705, 30810, 30910	6	55329-55340	84
1687	33	31105, 31210, 31310	5	55663, 55666	77
1705	30	31505, 31610, 31710	6	55667	80
1709	115	32005, 32110, 32210	5	55673	77
1711	31	37028-37031	11	55676	80
1720	34	38056, 38057, 38061	10	55797, 55801, 55807	77
1723	34	38059	14	55711, 55794	80
1753	29	38063-38069	15	55828, 55829	80
3410, 3415, 3420	34	38070-38073	10	55863, 55871-55879	85
4867, 4887	115	38101-38103	10	55905, 55910, 55915, 55973	85
5965, 5969	115	38108-38111, 38114	10	55975, 55980, 55984, 55993	85
6218-6320	79	38116	14	56000, 56200, 56205	16
9907-9949	78	38125, 38141	15	56800-57107	81
10254	87	39749	13	57300, 57301	21
11000	94	40102-40501	5	57501, 57502, 57510-57513	19
11018	95	40680-40688	6	57601, 57602	21
11027-11029	95	40701-40901	6	57639-57643, 57645-57668	20
11042	96	41000	6	57700-57703, 57705	19
11047, 11049-11051	95	41101-41301	5	57710, 57715	18
11052	99	4200-4220	78	57901-57904	19
11670-11685	99	4260-4265	79	57912, 57913, 57915, 57920	19
20011	18	42001-42201	5	58400, 58402, 58499	21
20015	119	42260-42269	15	58600-58608, 58615-58624	83
20021	122	42275-42304	12	59012, 59013	104
20022	128	42330-42340	9	59021	14
20023, 20024	124	42397, 42405, 42415, 42801, 43401, 43405, 44556, 44557, 44559, 44560, 45300, 45400, 45401, 45460, 45461, 45464, 45465, 45889, 45890, 46111, 46112, 48571, 48572	8 & 9	59030, 59040	1
20025	126	42680	7	59300, 59302	19
20032, 20033	131	48490-48500	9	60024	75
20034	121	50408-50412	19	60025-60036	74
20039-20071	118	52010-52025	18	60065-60076	75
20184-20220	119	52841	19	60088, 60089, 60090-60113	20
20481-20509	123	52865-52878	101	60119, 60120-60140	75
20510-20512	122	52869	102	60146-60157	103
20513	123	54101	19	60160, 60161, 60164-60167	4
20555	129	54410, 54510, 54300-54405	17	60170-60173, 60176-60178	4
20657-20701	124	54705-54732	104	60181-60189	67
20702-20752	126	54740, 54741-54752	105	60197, 60200, 60201-60265	76
20753-20773	127	54766-54782	102	60300, 60301, 60303	15
20856-20859	121			60305, 60306	45
20860-20872	129			60313-60315	21
21277	47			60340, 60343-60348	105



NUMERICAL INDEX

60402-60404.....	37	72718	68	75590, 75592	89
60406-60409, 60413.....	37	72721-71724.....	69	75600, 75602	90
60427-60436.....	35	72725-72752, 72761-72788	70	80753, 80754	48
60445-60451.....	27	72810, 72811, 72814	74	80760	47
60462-60465, 60471-60473	28	72818-72822	73	80762, 80766-80768, 80771.....	48
60482-60485.....	27	72827-72829.....	74	80800, 80801, 80803, 80805	45
60506-60509, 60515-60517	37	72834-72836	73	81886, 81889	63
61000	51	72840, 72841	71	82020	18
61001, 61002, 61037-61087.....	52	72845-72847, 72851	73	82240, 82241, 82243, 82245	47
61003, 61010-61035.....	51	72855-72857, 72860.....	71	82247	73
61090-61125.....	51	72865-72867, 72869, 72871.....	71	82250, 82254, 82260-82265.....	66
61004, 61130-61175.....	53	72880-72882, 72885, 72886.....	72	82275	74
61005, 61180-61205.....	54	72887, 72890, 72892	72	82295, 82297, 82298	59
61006, 61210-61258.....	55	72895-72897	71	82326, 82327	59
61007, 61260-61300.....	56	73148	62	82330-82334.....	58
61008, 61310-61327.....	57	74311-74315.....	58	82336-82355.....	63
70201, 70202	46	75103	109	82419-82426, 82431-82433	61
70221	44	75106-75129.....	110	82451-82457, 82460.....	74
70226, 70227, 70235, 70301	46	75130-75142.....	111	84785-84787.....	103
70360-70362.....	50	75148, 75149	112	85333, 85336-85339.....	3
70365-70398, 70405.....	49	75150-75157.....	111	85346-85349.....	4
70399-70404.....	50	75160-75176, 75190-75192	112	85355, 85358, 85359	3
70469-70476.....	41	75183-75189, 75193-75196	113	85362	26
70479, 70480	43	75210	87	85365-85371.....	4
70483	42	75215-75260.....	88	85372, 85376-85378.....	3
70484, 70485	41	75303, 75304	91	85801	4
70488-70491	40	75305	90	86101	23
70500, 70501	38	75306	89	86102-86104.....	22
70503	40	75307	90	86109, 86113	23
70504, 70505	39	75309, 75315	89	86116, 86112	25
70506	40	75316, 75317	90	86119, 86120, 86122	22
70507-70510.....	42	75318, 75319	91	86124-86130.....	23
70516-70523.....	39	75320	89	86131	23
70600, 70601, 70610	38	75321	90	86135-86138.....	23
70709, 70710, 70714	44	75322	89	86148, 86149	24
70718, 70722	45	75323, 75324	90	86139	25
70715-70517.....	46	75329-75334.....	94	86140	22
70730, 70731, 70735, 70736	47	75336, 75337, 75340	97	86145, 86146	23
70738-70743, 70756-70758	48	75343, 75347-75349.....	100	86150-86160, 86161.....	36
70762, 70763, 70770, 70771	48	75353-75355, 75357-75362	92	86189, 86190	25
70773, 70776-70779.....	48	75363-75366.....	95	86210	26
70795-70797.....	45	75367, 75368	96	86224, 86228	26
70802, 70807	45	75370, 75380, 75381	98	87070, 87071	32
70811	44	75385	92	87080, 87081	33
70816-70825.....	1	75398-75402.....	89	87084, 87086, 87087	33
71556-71568.....	65	75403	98	87090-87093.....	30
71680-71682, 71685-71696	67	75406-75425.....	99	87100-87102, 87104.....	31
71720, 71725-71728.....	62	75442-75445.....	2	87131	35
71736-71771.....	62	75447-75449.....	92	87147, 87151	24
71780, 71782, 71784, 71786	63	75450-75456.....	2	87155-87157.....	24
71788, 71790, 71792, 71794	63	75470	89	87200-87205.....	35
71797	63	75471, 75472	90	87207, 87220	35
71798	59	75473	91	87495-87497.....	26
71803-71806.....	62	75474	90	87727-87730.....	26
71810, 71812	58	75475, 75476, 75478	89	87731-87736.....	24
71813, 71815	63	75479, 75480	90	87790	27
71825, 71826, 71828, 71829	58	75482	91	87791	28
71865, 71866	63	75483	90	87795	32
71903-71908, 71914, 71915.....	66	75484, 75485	89	87796	28
71922-71926.....	63	75487-75489.....	97	87805	25
71969-71979, 71983-71998	60	75490, 75491, 75493	100	87822-87826.....	27
72005-72007.....	47	75494	94	87864, 87868	28
72040	66	75496	100	88066	23
72246, 72257	73	75498-75503.....	2	88107, 88108	10
72307, 72308	58	75507-75516.....	98	92012, 92016	101
72363-72367.....	71	75519	89	92020, 92025	101
72369-72373, 72376, 72377.....	63	75522-75527.....	91	93097	14
72386	59	75528	100	RBMC64218T25	13
72390-72392, 72394.....	61	75529	94	SA993	115
72395, 72397, 72399	61	75530-75540.....	93		
72461-72472.....	74	75541-75543.....	96		
72485-72496.....	75	75546, 75547	97		
72500, 72501	108	75548-75552.....	95		
72505	115	75555, 75556, 75558	96		
72506-72599.....	107	75560, 75562	96		
72600-72669.....	106	75565	95		

NOTES

NOTES

air fittings, hoses, tools and accessories

Premium Name Brand Air Accessories

Four distinct plug and coupler designs that do not interchange.

Color coding identifies each design style:

- RED (Industrial Milton® compatible) carded plugs and couplers work together
- YELLOW (Tru-Flate®) carded plugs and couplers work together
- GREEN (Aro® compatible) carded plugs and couplers work together
- BLUE (Lincoln® compatible) carded plugs and couplers work together

Sizing Standards:

- 1/4" NPT standard fitting body size
- 3/8" NPT heavy-duty fitting body style.

Eight color coded panels separate the products into eight user friendly groups;

- Plugs and couplers (Red, Yellow, Blue, Green)
- Blowguns
- Tire inflator gauges
- Air line accessories
- Regulators and filters

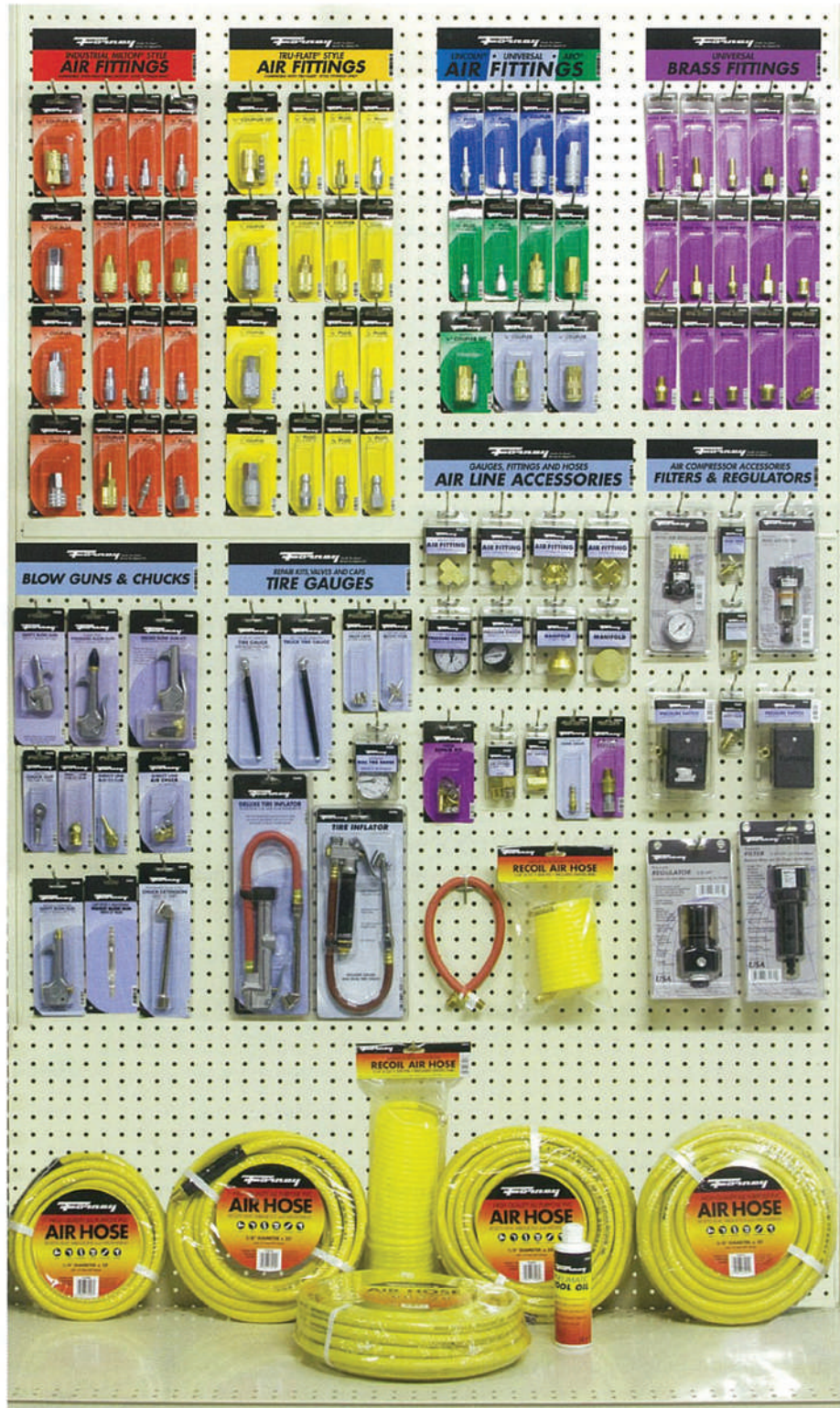

Forney

Service You Expect.
From a Company You Can Depend On.



Regina, SK

Email: forney@myaccess.ca

Hawkesbury, ON

Email: forneyhawk@on.aibn.com

FORNEY CANADA

Regina, Saskatchewan • Hawkesbury, Ontario

www.forneycanada.com