



Instruments

GDT-3200

7 Function Auto Ranging Digital Multi-Meter

Owners Manual

- Read this owners manual thoroughly before use and save

Milwaukee, WI 53209
1.800.822.9220
www.gardnerbender.com
ZX403

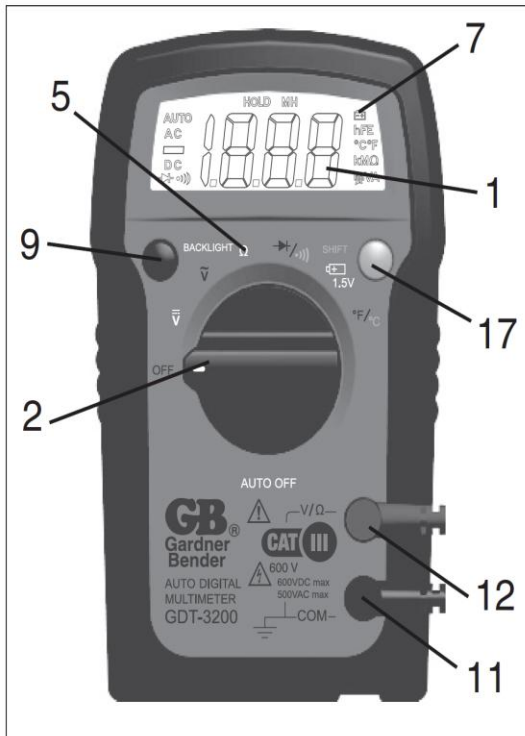

- | | | |
|--|--|--|
| 1. 3 1/2 digit LCD display
Pantalla de cristal líquido de 3 1/2 dígitos
Affichage numérique 3 1/2 po | 7. Temperature (-40F – 752F)
Temperatura (-4.4C a 400C)
Température (-4.4 °C - 400 °C) | 13. Wrap around lead storage
Almacenamiento envolvente de conductores
Rangement des fils par enroutage |
| 2. 7 position Function dial
Dial de funciones de 7 posiciones
Sélecteur de fonction 7 positions | 8. Backlight button
Botón de luz posterior
Test de pile | 14. Snap in probe storage
Almacenamiento insertable de la sonda
Rangement des sondes par pression |
| 3. AC Volts
Volts de CA
Volts c.a. | 9. Backlight button
Botón de encendido y apagado
Bouton de rétro éclairage | 15. Magnetic hanging strap
Correa colgadora magnética
Courroie avec aimant |
| 4. DC Volts
Volts de CC
Volts c.c. | 10. Low Battery Indicator
Indicador de batería baja
Indicateur de pile faible | 16. Protective rubber boot
Manguito de caucho protector
Gaine protectrice de caoutchouc |
| 5. Resistance
Resistencia
Résistance | 11. Common input jack
Toma de entrada común
Prise d'entrée commune | 17. Mode Select Button
Botón de selección de mod
Bouton de sélection de Mode |
| 6. Continuity/Diode Test
Prueba de continuidad/diodo
Test de continuité/diode | 12. Positive input jack
Toma de entrada positiva
Prise d'entrée positive | |

Meter type: Auto ranging
Functions: 7
Ranges: Auto ranging
Display Count: 2000
Input impedance: 10 Meg Ohm
AC Volt ranges: 200 / 500 (2.5% + 5 digits)
DC Volt Ranges: .2 / 2 / 20 / 200 / 600 (1.2%+2 digits)
Resistance Ranges: 200 / 2k / 20k / 200k / 2M (1.5% + 2 digit)
Continuity/Diode Function: selectable
Temperature Range -40F – 752F
Battery Test Ranges: 1.5 Volt
Auto Off 30 Minutes
Battery type: 2-AAA
Battery Life: 100 hours with carbon-zinc cells, 200 hours with alkaline cells under normal conditions.
Over Range Indication: The three least significant digits are blank and the number "1" is displayed at the left when the range capacity is exceeded by the input.
Polarity Indication: "-" is displayed for negative polarity
Agency Approvals: ETL, CE, CAT III 600V

Contents

- | | |
|----------------------------|--------------------------------------|
| 1. Meter Functions | 5. DC Volts Measurement |
| 2. Specifications | 3.2 DE Volts |
| 2.1 For Your Safety | 6. Resistance/Continuity Measurement |
| 3. Operating Instructions | 3.3 Resistance |
| 3.0 Operating Instructions | 8. Battery |
| 4. AC Voltage Measurement | 3.3 Household Battery Testing |
| 3.1 AC Volts | 9. Battery Replacement |

1.0 METER FUNCTIONS

2.0 READ FIRST: IMPORTANT SAFETY INFORMATION



Read this operators manual thoroughly before using this multimeter. This manual is intended to provide basic information regarding this meter and to describe common test procedures which can be made with this unit. Many types of appliance, machinery and other electrical circuit measurements are not addressed in this manual and should be handled by experienced service technicians.



Use extreme caution when using this multimeter. Improper use of this meter can result in severe damage to property, severe personal injury or death. Follow all instructions and suggestions in this operators manual as well as observing normal electrical safety precautions. Do not use this meter if you are unfamiliar with electrical circuits and proper test procedures.

2.1 For Your Safety

- 1) Use extreme caution when checking electrical circuits.

 2) Do not stand in wet or damp work areas when working with electricity. Wear rubber soled boots or shoes.

 3) Do not apply more voltage or current than the set range of the multimeter will allow

 4) Do not touch the metal probes of the test leads when making a measurement.

 5) Replace worn test leads. Do not use test leads with broken or tattered insulation.

- 6) Discharge a capacitor before measuring it.
- 7) Remove the test leads from the circuit being measured as soon as the test is completed. Never reset the function/range switch to another range while the leads are still in contact with a circuit.
- 8) Do not measure voltage when the function/range switch is set on the resistance (ohms) settings. Do not measure current when the meter is set on the resistance range. Never measure AC voltage when the meter is set on DC voltage. Setting the meter on the incorrect function may burn out some of the internal circuitry and may pose a safety hazard.
- 9) Damaged meters are not repairable nor is calibration possible. Damaged meters should be disposed of.

3.0 Operating Instructions

1. Set the function/range switch to the proper position before making a measurement. When the voltage is not known, it MUST be determined that the capacity of the selected range will handle the amount of voltage in the circuit (see #3 under "For Your Safety").
2. Avoid placing the meter in areas where vibration, dust or dirt are present Do not store the meter in excessively hot, humid or damp places. This meter is a sensitive measuring device and should be treated with the same regard as other electrical and electronic devices.
3. When the meter is not in use keep the meter turned to keep the battery from discharging.
4. When disconnecting the test leads from the unit, always grasp the leads where the input jacks meet the tester housing. Do not pull the leads out of the jacks by the insulated wire or transport the tester using the test leads as a carrying strap.
-  5. Do not immerse the meter in water or solvents. To clean the housing use a damp cloth with a minimal amount of mild soap.

NOTE: With any measurement made by this meter, there will be some fluctuation of the digital display. This is due to the meter's sampling method. This unit samples at a rate of 2 times per second, thus the fluctuation of the readout.

Dial Settings

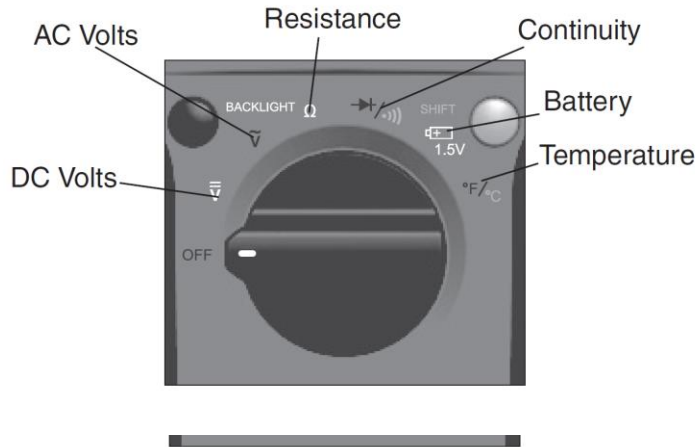

3.1 AC Volts

There are two ranges for measuring AC voltage, 200 V and 500 V. For more accurate measurements under 200 volts use the 200 Volt setting.

1. Set the function/range switch to the appropriate AC V range shown above.
2. Touch the test leads to the circuit under test. With AC voltage, the polarity of the test leads is not a factor.

NOTE: It is best to touch one of the test leads to ground or Neutral first and then touch the 2nd test lead to the hot wire.

3. Read the value of the measurement displayed.
4. Typical AC Voltage measurements include wall outlets, appliance outlets, motors, light fixtures and switches. When measuring outlets the specially spaced lead holders allow for single one hand testing.

3.2 DC Volts

There are four ranges for measuring DC voltage, 2, 20, 200 V and 600 V. For more accurate measurements use the lowest range possible without exceeding the value.

1. Set the function/range switch to the appropriate DC V range shown above.
2. Touch the test leads to the circuit under test. With DC voltage, the polarity of the test leads is a factor. Touch the black (common) test lead to the negative DC source first and red (positive) test lead to the "live" source second.
3. Read the value of the measurement displayed. If the leads are reversed a "-" indicator will appear on the display.
4. Typical DC Voltage measurements include car batteries, automotive switches and household batteries.

3.3 Resistance

There are five ranges for measuring resistance 200, 2K, 20K, 200K and 2 Meg Ohms. For more accurate measurements use the lowest range possible without exceeding the value.

⚠ WARNING when measuring resistance always make sure the power is off.

1. Set the function/range switch to the appropriate resistance (ohms) range shown above.
2. Touch the test leads to the resistor or non-energized component to be measured. Use the 2000K range when testing for resistance values in electronic components such as resistors and potentiometer. If the value of the component falls within the range of another setting, reset the function/range switch to that setting for a more accurate reading.
3. Read the value of the measurement displayed. With resistance measurements, the polarity of the test leads is not a factor.
4. Typical resistance/continuity measurements include resistors, potentiometer, switches, extension cords and fuses.

3.4 Diode / Continuity Testing

There is only one range for measuring continuity and diodes. To change between these two functions use the mode select button on the right.

⚠ WARNING when measuring diodes or continuity always make sure the power is off.

3.4.1 Continuity

1. Set the function switch to the continuity/diode [show symbols] position.
 2. Select the continuity mode by pushing the mode select button on the right.
 3. Touch the test leads to the component or circuit to be tested. Polarity of the test leads is a factor. Touch the black (common) test lead to the negative (-) terminal and the red test lead to the positive (+) terminal.
- Read the value of the measurement displayed. If the leads are reversed a “-“ indicator will appear on the display.

3.4.2 Diodes

1. Set the function switch to the continuity/diode [show symbols] position.
2. Select the diode mode by pushing the mode select button on the right.
3. Diodes should be tested with both forward and reverse voltages applied. Touch the test leads to the diode, one lead on the anode and the other on the cathode. The indication of a diode in good condition is a low resistance reading when the red lead is on the anode and the black lead is on the cathode. When the test leads are reversed, a high resistance reading should be displayed.

NOTE: A low resistance in both directions indicates a shorted diode; a high resistance in both directions indicates an open diode.

3.5 Temperature Measurements

NOTE: The standard test leads are not used for temperature measurement and can be removed from the meter.

1. Plug the temperature probe into the input jacks.
2. Set the function select dial to the “TEMP” setting. The display should now read the ambient (surrounding) temperature.
3. Touch the temperature probe to the object under test. Hold the probe to the object until a steady reading is maintained on the display.
4. To select between F° and C°, push the mode select button.

3.6 Household Battery Testing

There is only one range for measuring common 1.5 Volt household batteries. (AAA, AA, C or D size)

1. Set the function switch to the battery position.
2. Touch the test leads to the positive and negative terminals on the battery. With DC voltage, the polarity of the test leads is a factor. Touch the black (common) test lead to the negative (-) terminal and the red test lead to the positive (+) terminal.
3. Read the value of the measurement displayed. If the leads are reversed a “-“ indicator will appear on the display.

Battery Replacement

1. Remove the screws in the back cover of the tester and carefully separate the back cover from the front.
2. Remove the battery from the contacts, noting the polarity of the battery terminals and contacts.
3. Replace with one fresh 9 Volt battery.

Note: Do not use rechargeable batteries in this unit.

4. Carefully, replace the back cover and tighten the screws. Do not overtighten the screws as this may strip the threads in the tester housing.