

HITACHI

Stapler

N 5008AC2

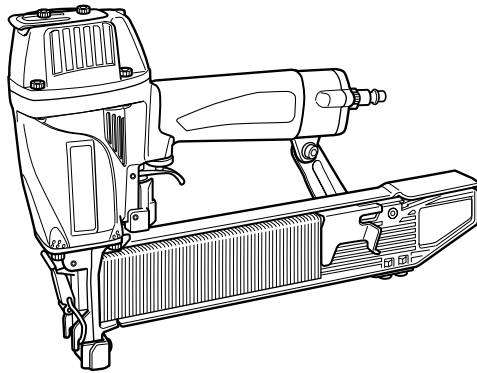

Read through carefully and understand these instructions before use.
Keep this Manual available for others before they use the Stapler.

Handling instructions

GENERAL OPERATIONAL PRECAUTIONS

- 1. Operate the power tool safely for correct uses.**
Do not use the power tool for uses other than those specified in this instructions.
- 2. For safe operation handle the power tool correctly.**
Please follow the instructions given in this instruction manual and correctly handle this tool so as to ensure safe operation. Never let the tool be use by children or people who do not know enough to be able to handle it correctly, or let it be used by people who cannot operate it correctly.
- 3. Confirm the safety of the workshop.**
Keep unauthorized people away from the workshop. Especially children should be kept away.
- 4. The right parts in the right places.**
Do not remove any of the covers or screws. Keep them in place as they have their functions. Moreover, because it would be dangerous, never make modifications to the tool or use it after making modifications.
- 5. Check the tool before using it.**
Before using the tool, always check that no parts of it are broken, that all screws are completely tight, and that no parts are missing or rusty.
- 6. Excessive work could cause accidents.**
Do not make tools and accessories work beyond their abilities. Excessive work not only damages the power tool but also is dangerous in itself.
- 7. Stop operation immediately if abnormalities are noticed.**
Stop operation if you notice abnormalities, or if the power tool does not work properly; have the power tool inspected and serviced.
- 8. Look after the power tool carefully.**
If you drop or knock the power tool against things, the outer frame may be deformed and cracks or other kinds of damage may occur, so please handle it with sufficient care. Also, do not scratch or engrave signs on the power tool. Owing to high pressure air inside the tool, cracks in the surface are dangerous. Never use the power tool if a crack develops or if air is escaping from a crack.
- 9. Take good care for a long life.**
Always take good care of the power tool and keep it clean.
- 10. Inspection at regular intervals is essential for safety.**
Inspect the power tool at regular intervals so that the power tool can be operated safely and efficiently at all times.
- 11. Consult an authorized service agent if repair or parts replacement is necessary.**
Ensure that the power tool is serviced by authorized service centers only, and that only genuine, replacement parts are used.
- 12. Keep the power tool in a proper place.**
When not in use, the power tool should be kept in a dry place out of the reach of children. Put into the body about 2cc oil through the hose joint to protect the tool from rust.
- 13. The exploded assembly drawing on this handling instructions should be used only for authorized service center.**

PRECAUTIONS ON USING STAPLER

- 1. Safe operation through correct usage.**
This tool was designed for driving staples into wood and similar materials. Use it for its intended purpose only.
- 2. Make sure air pressure is within the rated range of air pressure.**
Fastener driving tools operated by compressed air shall only be connected to compressed air lines where the maximum allowable pressure cannot be exceeded by a factor of more than 10% which can for example be achieved by a pressure reduction valve which includes a downstream safety valve. (For model N5008AC2, 110% of rated maximum allowable pressure is 9.1 bar = 130 psi)

Fastener driving tools operated by compressed air should only be operated at the lowest pressure required for the work process at hand, in order to prevent unnecessarily high noise levels, increased wear and resulting failures.
- 3. Never operate the equipment with high-pressure gases other than compressed air.**
Never use carbon dioxide, oxygen or another gas from pressurized containers under any circumstances.
- 4. Be careful of ignition and explosions.**
Since sparks may fly during stapling, it is dangerous to use this tool near lacquer, paint, benzine, thinner, gasoline, gas, adhesives and similar inflammable substances as they may ignite or explode. Under no circumstances should this tool therefore be used in the vicinity of such inflammable material.
- 5. Always wear eye protection (protective goggles).**
When operating the power tool, always wear eye protection, and ensure that surrounding people wear eye protection too.
The possibility of fragments of staples or staples that were not properly hit entering the eye is a threat to sight. Eye protection can be bought at any hardware store. Always wear eye protection while operating this tool. Use either eye protection or a wide vision mask over prescription glasses. Employers should always enforce the use of eye protection equipment.
- 6. Protect your ears and head.**
When engaged in stapling work please wear ear mufflers and head protection. Also, depending on condition, ensure that surrounding people also wear ear mufflers and head protection.
- 7. Pay attention to those working close to you.**
It would be very dangerous if staples that were not properly driven in should hit other people. Therefore, always pay attention to the safety of the people around you when using this tool. Always make sure that nobody's body, hands or feet are close to the staple outlet.
- 8. Never point the staple outlet towards people.**
Always assume the tool contains fasteners. If the staple outlet is pointed towards people, serious accidents may be caused if you mistakenly discharge the tool. When connecting and disconnecting the hose, during staple loading or similar operations, be sure the staple outlet is not pointed towards

anyone (including yourself). Even when no staples are loaded at all, it is dangerous to discharge the tool while pointing it at someone, so never attempt to do so. No horseplay. Respect the tool as a working implement.

9. **Before using the power tool, check the push lever.**
Before using the power tool make sure to check that the push lever and valve operate properly. Without staples loaded into the power tool, connect the hose and check the following. If the sound of operation occurs this indicates a fault, so in such a case do not use the power tool until it has been inspected and repaired.
 - If merely pulling the trigger causes operating sound of drive bit movement occur, the power tool is faulty.
 - If merely pushing the push lever against the material to be stapled causes the sound of drive bit movement to occur, the power tool is faulty. Furthermore, with regard to the push lever, please note that it must never be modified or removed.
10. **Use specified staples only.**
Never use staples other than those specified and described in these instructions.
11. **Be careful when connecting the hose.**
When connecting the hose and loading staples in order not to fire the tool by mistake, make sure of the following.
 - Do not touch the trigger.
 - Do not allow the firing head to contact with any surface.
 - Keep the firing head down.Strictly observe the above instructions, and always make sure that no part of the body, hands or legs is ever in front of the staple outlet.
12. **Do not carelessly place your finger on the trigger.**
Do not place your finger on the trigger except when actually stapling. If you carry this tool or hand it to someone while having your finger on the trigger, you may inadvertently discharge a staple and thus cause an accident.
13. **Completely Close the blade guide and do not open it during operation.**
If stapling is attempted when the blade guide is open, staples will not be driven into the timber, and there is a risk of dangerous discharge.
14. **Press the staple outlet firmly against the material to be stapled.**
When driving in staples, press the staple outlet firmly against the material to be stapled. If the outlet is not applied properly, the staples may rebound.
15. **Keep hands and feet away from the firing head when using.**
It is very dangerous for a staple to hit the hands or feet by mistake.
16. **Beware of the tool's kickback.**
Do not approach the top of the tool with your head etc. during operation. This is dangerous because the tool may recoil violently if the staple currently being driven in comes into contact with a previous staple or a knot in the wood.
17. **Take care when stapling thin boards or the corners of wood.**
When stapling thin boards, the staples may pass right through, as may also be the case when stapling the corners of wood due to deviation of the staples. In such cases, always make sure that there is no one (and nobody's hands or feet; etc.) behind the thin board or next to the wood you are going to staple.
18. **Simultaneous stapling on both sides of the same wall is dangerous.**
Under no circumstances should stapling be performed on both sides of a wall at the same time. This would be very dangerous since the staples might pass through the wall and thus cause injuries.
19. **Do not use the power tool on scaffoldings, ladders.**
The power tool shall not be used for specific application for example:
 - when changing one driving location to another involves the use of scaffoldings, stairs, ladders or ladder alike constructions, e.g. roof laths,
 - closing boxes or crates,
 - fitting transportation safety systems e.g. on vehicles and wagons
20. **Do not disconnect the hose with your finger on the trigger.**
If you disconnect the hose with your finger on the trigger, the next time the hose is connected, there is a danger that the power tool will fire a staple spontaneously, or operate incorrectly.
21. **Disconnect the hose and take out any staples left in the magazine after use.**
Disconnect tool from air before doing tool maintenance, cleaning a jammed fastener, leaving work area, moving tool to another location, or after use. It is very dangerous for a staple to be fired by mistake.
22. **When removing a staple which has become stuck, make sure to first of all disconnect the hose and release compressed air.**
When removing a staple which has become stuck in the staple outlet, first of all make sure to disconnect the hose and release compressed air inside the power tool.
Accidental firing of the staple could be very dangerous.
23. **To avoid hazards caused by falling staples, never open the magazine with the device facing downward while loading staples.**
24. **A female plug (air socket) should not be used in the body.**
If a female plug is installed in the body, the compressed air sometimes can not be drawn when the hose is disconnected so avoid this.
The tool and air supply hose must have a hose coupling such that all pressure is removed from the tool when the coupling joint is disconnected.
25. **When cleaning the power tool, do not use gasoline or other inflammable liquids.**
If vapour from an inflammable liquid gets into the power tool, there is a danger that sparks produced when stapling etc. may cause an explosion.

NAME OF PARTS

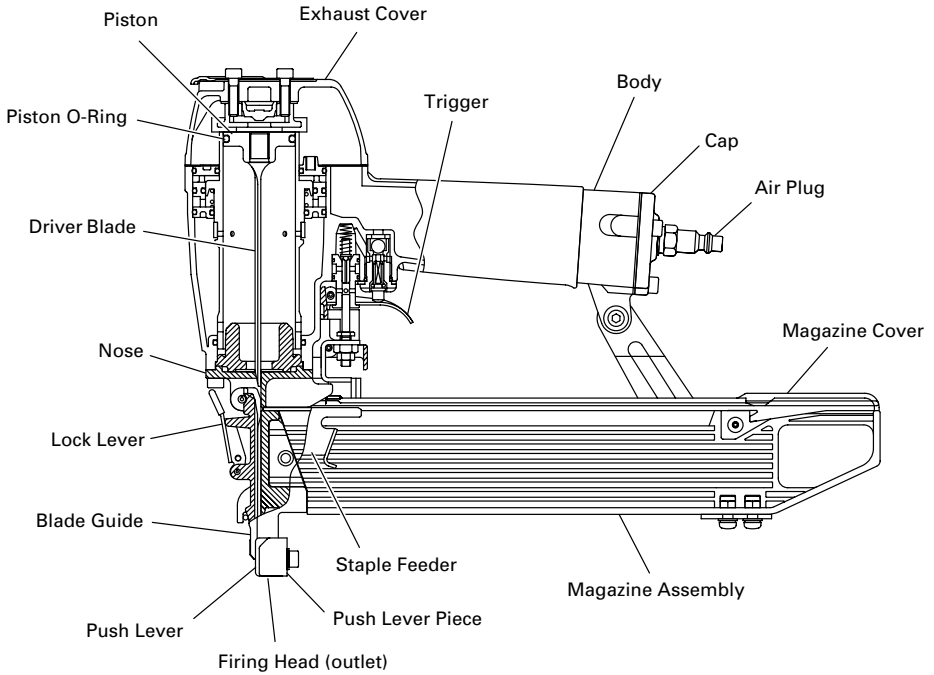

Fig. 1

SPECIFICATIONS

Type of power	Piston reciprocating
Air pressure (Gauge)	4.9 – 8.3 bar (70 – 120 psi.)
Applicable staples	ref. Fig.
Amount of loadable staples	150 staples
Size	365 mm (L) × 258 mm (H) × 76 mm (W) (14-3/8" × 10-5/32" × 3")
Weight	2.0 kg (4.4 lbs)
Hose (inside diam.)	6 mm (1/4")

STAPLE SELECTION

Choose a suitable staple from Fig. Staples which are not shown in Fig. can not be driven with this tool.

16 Gauge 7/16" Crown	
Min.	Max.

Dimension of staples

STANDARD ACCESSORIES

- (1) Hexagon bar wrench for M5 screw
- (2) Eye protection

OPTIONAL ACCESSORY

- Sequential Trip Mechanism Kit (Code No.876762) (Sequential Fire Parts Set, Single Shot Parts)
With the sequential fire parts, the staple is driven only by squeezing the trigger after pushing down the push lever.
By installing these parts, driving staples into improper positions and unexpected firing of staples caused by accidental operation of the push lever can be prevented.

APPLICATIONS

- Construction work such as wall sheathing, subflooring.
- Mobile and modular home construction.

PREPARATION PRIOR TO OPERATION

1. Prepare the hose

Be sure to use the hose provided with minimum 6 mm (1/4") inside diameter.

NOTE:

The air supply hoses must have a minimum working pressure rating of 12.8 bar (180 psi) or 150 percent of the maximum pressure produced in the air supply system, whichever is higher.

2. Check on safety

CAUTIONS:

- Unauthorized persons (including children) must be kept away from the equipment.
- Wear eye protection.
- Check the retaining screws which fix the exhaust cover, etc. for tightness.
Check the stapler for air leaks and defective or rusty parts.
- Check whether or not the push lever works correctly. Also check whether or not any dirt has adhered to the moving parts of the push lever.
- Recheck on operational safety.

BEFORE USE

1. Check the air pressure

CAUTION:

The air pressure must be constantly maintained at 4.9 – 8.3 bar (70 – 120 psi.).

Adjust the air pressure between 4.9 to 8.3 bar (70 – 120 psi.) according to the diameters and length of staples and hardness of the wood being stapled. Pay special attention to the output pressure, capacity, and piping on the air compressor, so that air pressure does not exceed the specified limit. Note that excessive pressure may affect overall performance, service life, and safety.

2. Lubrication

- (1) Prior to operating this stapler, be sure to provide an air set between the air compressor and this device. Lubrication through the air set offers smooth operation, extended service life, and anticorrosion. Adjust the oiler so that a single drop of oil is supplied at intervals of 5 to 10 stapling cycles.
- (2) It is recommended using the recommended oil (SHELL TONNA). Other applicable oils are listed. Never mix two or more types of different oils.

3. Load staples

CAUTIONS:

- When loading staples into stapler,
 - (1) do not depress trigger;
 - (2) do not depress push lever; and
 - (3) keep your face, hands feet and other body parts, as well as those of other persons away from the nose muzzle to avoid possible injury during usage and carrying.
- (1) Pull the staple feeder backward and attach it securely to a groove of the magazine. (See Fig. 2)

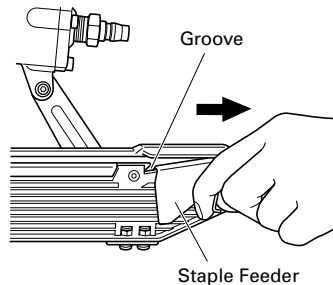

Fig. 2

- (2) Place the staple strip over the magazine. Make sure that the staple strip slides freely on the magazine. (See Fig. 3)

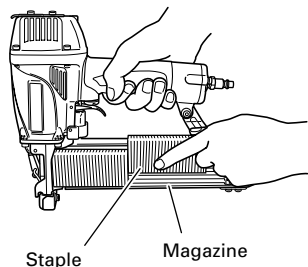

Fig. 3

- (3) Pull the staple feeder backward. Then, detach it from the groove of magazine and softly bring the staple back as if it were being gently pushed, avoiding any impact. (See Fig. 4)

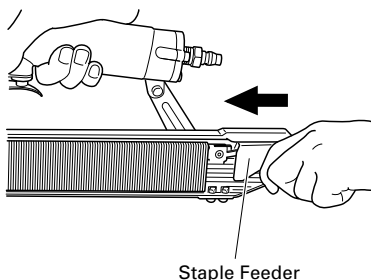

Fig. 4

The stapler is now ready to operate.

CAUTIONS:

- If the staple feeder is released all of a sudden, it can return abruptly, causing deformation and/or scatter, eventually ending up in clogged staples. Be absolutely sure to bring back the staple feeder, avoiding any impact.
- To prevent unintentional operation, never touch the trigger or place the top end of the push lever on a work bench on floor. Also, never face the staple outlet toward any part of a person.

HOW TO USE THE STAPLER

CAUTIONS:

- Never use the head or body of this device as a hammer.
- Take precautions to ensure the safety of persons in the vicinity during operation.

1. Stapling procedures

- (1) Intermittent stapling
Depress the staple outlet onto the desired point; then pull the trigger to drive a staple in a single shot. (See Fig. 5)

CAUTION:

- This tool will bounce and shoot several staples instead of just one in rapid succession when strongly pressed flush against a surface or when using on hard materials. In such cases, fire the staples by squeezing and quickly releasing the trigger.

- (2) Push lever

When depressing the staple outlet, be sure to fully lift the push lever (See Fig. 5) to release the safety lock. Thus, staples cannot be driven without releasing the safety lock even though the trigger is pulled.

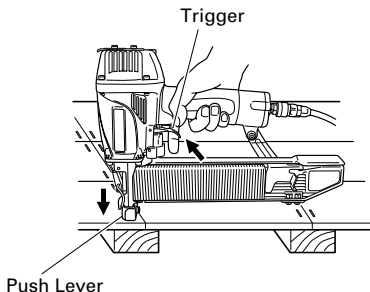

Fig. 5

- (3) Continuous stapling

First, pull the trigger. Then depress the device onto the desired position to automatically drive staples. (See Fig. 6).

Previously pull the trigger

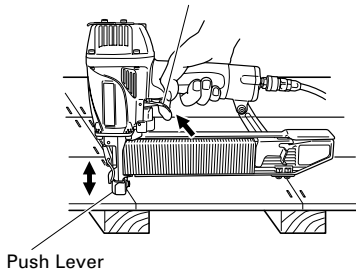

Fig. 6

CAUTIONS:

- Exercise care when stapling corners of lumber. When continuous stapling corners of lumber, a staple may go astray or break through the corner.
- Do not drive a staple on another staple.
- Do not drive a staple on metal parts.

NOTES:

- Precautions on no-load operation
Sometimes stapling will continue after driving in all staples previously contained in the magazine. This is termed "no-load operation". Such operation may deteriorate the bumper, magazine, and staple feeder.
To avoid no-load operation, occasionally confirm the amount of remaining staples. On the other hand, all staples should be removed after using this stapler.

- After stapling:
 - (1) disconnect air hose from the stapler;
 - (2) remove all staples from the stapler;
 - (3) supply 5 – 10 drops of Hitachi pneumatic tool lubricant into the air plug on the stapler; and
 - (4) open the petcock on the air compressor tank to drain any moisture.
- Under low temperature conditions, the machine sometimes does not operate correctly. Always operate the machine at the appropriate ambient temperature.

2. How to adjust the stapling depth

To assure that each staple penetrates to the same depth, be sure that:

- (1) the air pressure to the stapler remains constant (regulator is installed and working properly), and
- (2) the stapler is always held firmly against the workpiece.

If staples are driven too deep or shallow into the workpiece, adjust the stapling in the following order.

CAUTIONS:

- Before adjustment, always disconnect the hose and release compressed air in the power tool.
- During adjustment always keep your finger off the trigger.
- During adjustment make sure that no part of the body, hands, or legs is ever in front of the staple outlet.

Please carry out adjustments in the following order. (See Fig. 7)

To adjust the driven-in depth of a staple, loosen the screw that secures a push lever piece.

If the staple is driven in deeply, adjust the push lever piece to "down", and if it's driven in shallowly, adjust the push lever piece to "up".

Tighten the screw to fasten the push lever piece.

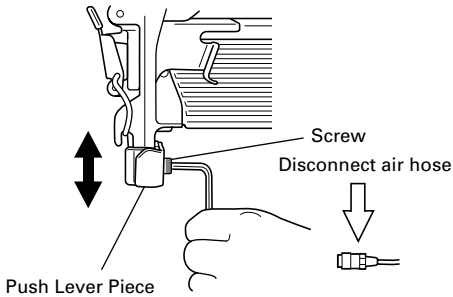

Fig. 7

NOTE:

- Please use the minimum air pressure that is sufficient to drive the staples to a suitable depth. If an overly high pressure is used, the life of the piston damper etc. will be shortened.

INSPECTION AND MAINTENANCE

CAUTION:

Be sure to disconnect the hose during cleaning jams, inspection, maintenance and cleaning.

1. Countermeasure for staple jamming

- (1) Remove all staples.
- (2) Release the lock lever and open the blade guide. (See Fig. 8)

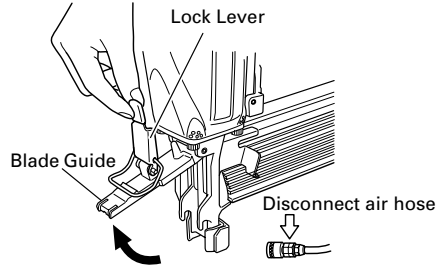

Fig. 8

- (3) Remove the jammed staple with a slotted-head screwdriver. (See Fig. 9)

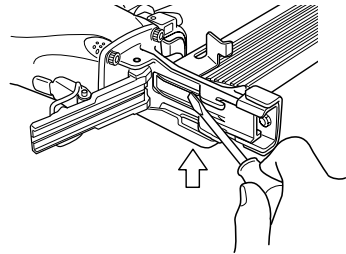

Fig. 9

- (4) Close the blade guide and latch.
- (5) In case of frequent jam, contact a Hitachi authorized service center.

2. Inspection and maintenance

Periodically inspect the device.

- (1) Remove the four hexagon socket hd. bolts securing the exhaust cover and remove the exhaust cover. Then, cylinder, piston, and other parts can be removed in respective assembly groups.

Wipe the drive bit, the piston sliding part and the body interior with a cloth to remove deposited dirt.

- (2) Confirm that the piston damper offers normal operation. A damaged piston damper may cause damage to other component parts.
- (3) Carefully check the O-ring for wear while disassembling. A worn or damaged O-ring may deteriorate overall performance. Replace a worn or damaged O-ring with new one.
- (4) Prior to reassembling the device, apply grease (Attolub No. 2 Grease) to the O-ring. Also, lubricate the device with the recommended oil.

3. Check on mounting screws for each part

At regular intervals check every part for loose mounting screws and whether or not there are any air leaks. Retighten any loose screws. Operating the equipment with loose screws untightened will incur a hazard.

4. Inspecting the push lever

Check if the push lever (Fig. 1) can slide smoothly. Clean up the sliding area of the push lever and use the provided oil for lubrication from time to time. Lubrication enables smooth sliding and simultaneously serves to prevent the formation of rust.

5. Storing

- When not in use for an extended period, apply a thin coat of the lubricant to the steel parts to avoid rust.
- Do not store the stapler in a cold weather environment. Keep the stapler in a warm area.
- When not in use, the stapler should be stored in a warm and dry place. Keep out of reach of children.

6. Service parts list

CAUTION:

Repair, modification and inspection of Hitachi Power Tools must be carried out by an Hitachi Authorized Service Center.

This Parts List will be helpful if presented with the tool to the Hitachi Authorized Service Center when requesting repair or other maintenance.

In the operation and maintenance of power tools, the safety regulations and standards prescribed in each country must be observed.

MODIFICATIONS:

Hitachi Power Tools are constantly being improved and modified to incorporate the latest technological advancements.

Accordingly, some parts may be changed without prior notice.

APPLICABLE LUBRICANTS

Type of lubricant	Name of lubricant
Recommended oil	SHELL TONNA
Motor oil	SAE10W, SAE20W
Turbine oil	ISO VG32 – 68 (#90 – #180)

COMPRESSOR

CAUTION:

When the maximum, operating pressure of the air compressor exceeds 8.3 bar (120 psi.), be sure to provide a reducing valve between the air compressor and nailer. Then, adjust the air pressure within the operating range of 4.9 ~ 8.3 bar (70 ~ 120 psi.). If the air set is installed, lubrication is also possible, thus providing additional convenience.

OILER-FILTER-REDUCING VALVE (Air Set)

So that the equipment can be operated under an optimum condition to ensure extended service life, it is advisable to use an oiler filter reducing valve. Please limit the length of the hose between the unit and the air set to within 10m when using. (Fig. 10)

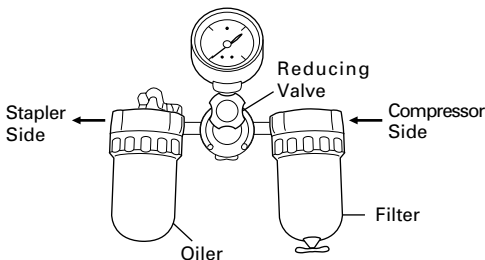
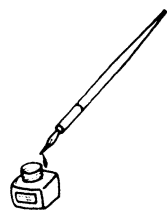
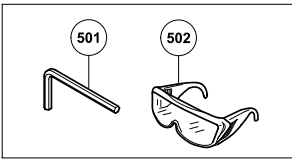
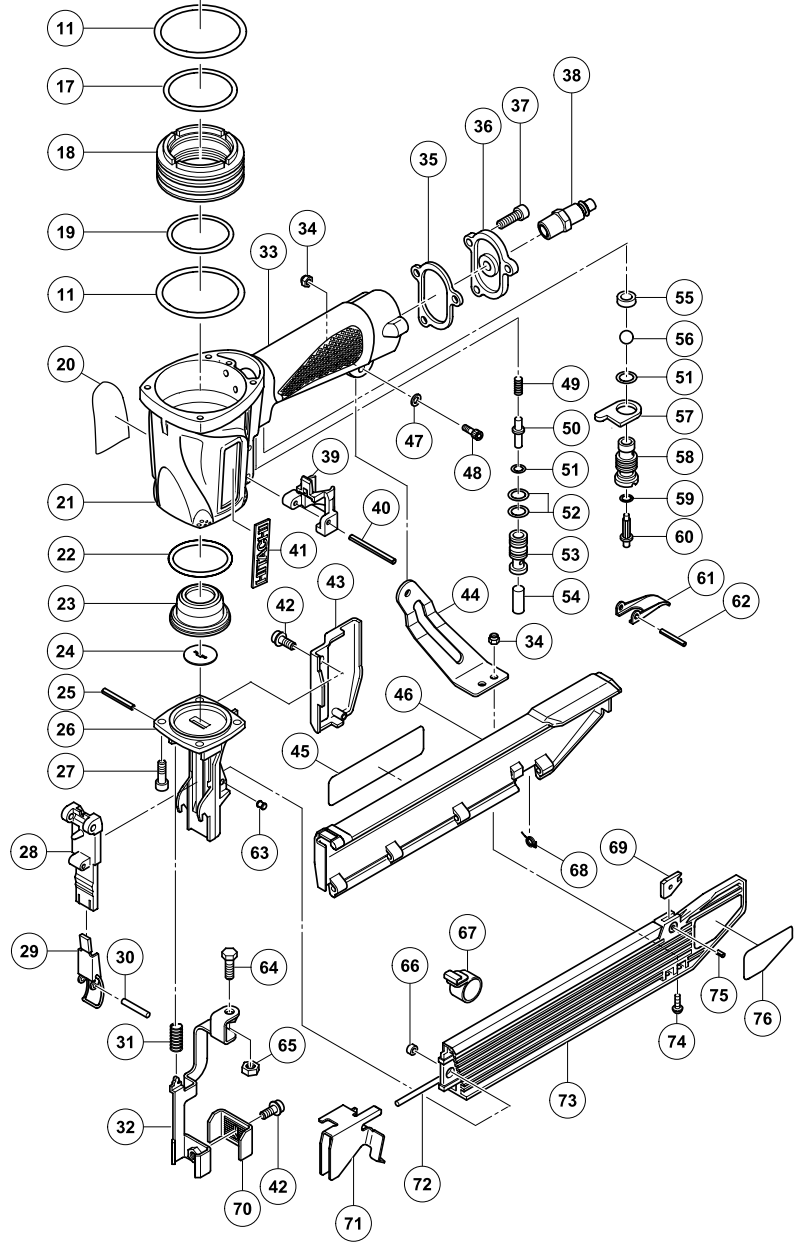
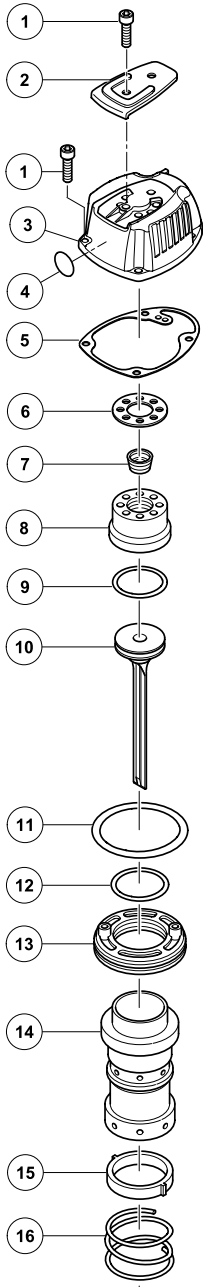

Fig. 10





Item No.	Part Name	Q'TY
1	HEX. SOCKET HD. BOLT M5 × 20	6
2	TOP COVER	1
3	EXHAUST COVER	1
4	WARNING LABEL(A)	1
5	GASKET (F)	1
6	GASKET (C)	1
7	EXHAUST VALVE	1
8	HEAD CAP	1
9	PISTON O-RING	1
10	PISTON	1
11	O-RING (I.D. 64.5)	3
12	CYLINDER O-RING (D)	1
13	CYLINDER PLATE	1
14	CYLINDER	1
15	CYLINDER RING	1
16	CYLINDER SPRING	1
17	CYLINDER O-RING (A)	1
18	CYLINDER GUIDE	1
19	CYLINDER O-RING (B)	1
20	NAME PLATE	1
21	BODY ASS'Y	1
22	CYLINDER O-RING (C)	1
23	PISTON BUMPER	1
24	BUMPER SHEET	1
25	ROLL PIN D4 × 36	1
26	NOSE	1
27	NYLOCK HEX. SOCKET HD. BOLT M5 × 16	4
28	BLADE GUIDE	1
29	LOCK LEVER	1
30	ROLL PIN D3 × 20	1
31	SPRING (B)	1
32	PUSHING LEVER	1
33	GRIP RUBBER	1
34	NYLON NUT M5	3
35	GASKET (D)	1
36	CAP	1
37	HEX. SOCKET HD. BOLT M5 × 16	3
38	AIR PLUG NPT 1/4	1
39	VALVE GUARD	1
40	ROLL PIN D3 × 45	1
41	HITACHI PLATE	1
42	NYLOCK BOLT (W/FLANGE) M5 × 8	2
43	GUARD	1
44	HANDLE ARM	1
45	WARNING LABEL	1
46	MAGAZINE COVER	1
47	WASHER	1
48	HEX. SOCKET HD. BOLT M5 × 18	1
49	PLUNGER SPRING	1
50	PLUNGER (A)	1
51	PLUNGER O-RING	1
52	O-RING (S-12)	3
53	VALVE BUSHING	1
54	PLUNGER (B)	1
55	VALVE PACKING	1
56	URETHANE BALL (C) D7.14	1
57	VALVE PLATE	1
58	TRIGGER VALVE BUSHING	1
59	PLUNGER O-RING	1
60	TRIGGER PLUNGER	1
61	TRIGGER	1
62	ROLL PIN D3 × 30	1
63	PIN	1
64	SAFETY BOLT	1
65	NUT M5	1
66	SHAFT RING	1
67	RIBBON SPRING	1

Item No.	Part Name	Q'TY
68	COVER SPRING	1
69	MAGAZINE PIECE	1
70	PUSHING LEVER PIECE	1
71	STAPLE FEEDER	1
72	HINGE PIN	1
73	MAGAZINE ASS'Y	1
74	MACHINE SCREW (W/WASHERS) M5 × 14	2
75	ROLL PIN D3 × 6	1
76	LABEL	1
501	HEX. BAR WRENCH 4MM	1
502	SAFETY GLASSES	1

 **Hitachi Koki Co., Ltd.**

809
Code No. C99173911
Printed in Taiwan