

INTEX®

2019

COMFORT Collection





Intex Development Co. Ltd., Hong Kong

Intex Recreation Corp, Long Beach, CA, USA

Intex Trading B.V., The Netherlands

Unitex Service (France) S.A.S., France

INTRODUCTION

The Intex Family of companies is dedicated to developing and manufacturing the highest quality products that not only provide the best value in price, but are innovative, fun and exciting. Backed by excellent Customer Service, Intex also provides first-rate after sales support. The 100+ independently owned and locally operated companies that make up the Intex Family, all embrace this commitment to quality, service and price and are committed to working together to ensure the satisfaction of the families and individuals in countries across the globe who enjoy these products. This has become the hallmark of Intex around the world.

As a true industry leader, Intex boasts state of the art factories, trained and motivated people, products that meet rigorous testing requirements, and a Customer Service organization that will go extra lengths to ensure our customers are satisfied and happy with their purchases.

When you purchase an Intex product you can be confident that you are buying the best product, at the best price, backed by the best Customer Service organization in the industry.



Intex Administration Building Landscape, Xiamen, China



Intex Manufacturing and Distribution Complex, Xiamen, China

Intex is committed to delivering top quality products at a great value with the backing of a responsive Customer Service organization. Our Airbed line is unmatched for breadth and beauty. With the introduction of our new innovative, patented Fiber-Tech™ Technology, we have engineered a way to combine durability with exceptional comfort, creating airbeds that rival the stability, support and comfort of a traditional mattress. The “Dura-Beam®” series utilizes superior Fiber-Tech™ interior construction to create a line of airbeds that are lighter, stronger, and more comfortable than an average airbed. With “PremAire®”, Intex has combined our manufacturing technologies with our engineering strengths of Fiber-Tech™ to bring you the most innovative, luxurious, and comfortable bed in the market today.

Our Comfort Rest® line of airbeds consists of four series designed to meet all of your customers' needs: the “Dura-Beam® Standard Series” offers a line of durable and comfortable airbeds with attractive opening price points. “Dura-Beam® Plus Series” features a wide variety of luxurious premium quality raised airbeds. Each airbed has been engineered and tested to provide you with superior functionality that guarantees the ultimate sleeping experience. Our top-of-the-line “PremAire® Airbeds” bring a new level of luxury and innovation to our collection. Elegantly designed with puncture resistant laminated PVC exterior, plushy pillow top and superb structural durability, PremAire® Airbeds bring you and your guests unparalleled comfort. The “Multi-Use / Camping” series is engineered for camping, travel, and all-around rugged use, with beds perfectly suited to the outdoor environment. And for the young at heart, our “Air Furniture” series comes with bright colors and fresh design concepts, guaranteed to attract a loyal following of young adults! Ask your Intex representative for any of our product catalogs – we are confident that you will agree that Intex's product line is unmatched in meeting your needs.

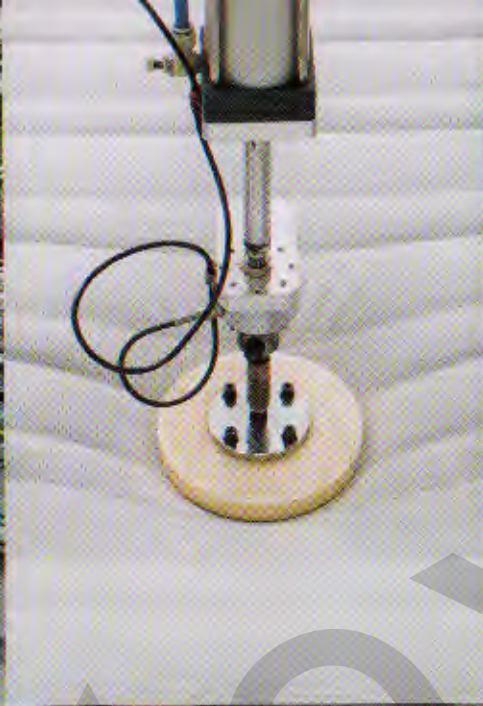

Commitment to Excellence

Intex's Commitment to Excellence encompasses every single product that leaves our factory. We achieve this by maintaining the highest levels of quality assurance — such as inflating and testing every single airbed to ensure the Air Lock® guarantee. It's that simple.



100% of our products are quality tested to be air tight before they leave our factory.

In today's rapidly evolving and highly competitive environment, this translates into a total commitment to product quality, including conformity to all relevant safety & quality regulations and standards. Examples include:

- EN 16927, Safety and test methods for mini pools (European standard)
- EN 16582, Safety and test methods for domestic swimming pools other than mini pools (European standard)
- Regulation (EC) No.1907/2006 "Registration, Evaluation, Authorisation and Restriction of Chemicals (REACH)"
- EN 71 "Safety of toys" (European standard)
- EN 13138 "Buoyant aids for swimming instruction" (European standard)
- EN15649 "Floating leisure articles for use on and in the water" (European standard for air mats, lounges and other similar items)
- EN 60335-2-41 "Safety of household and similar electrical appliances, particular requirements for pumps" (European standard for water pumps)
- ISO 6185-1 "Inflatable boats" (International standard for Sports Boats)
- NMMA-ABYC (USA standard for hi-end sports boats)
- ASTM F963 "Standard Consumer Safety Specification for Toy Safety" (USA toy standard)
- ANSI/APSP-4 "AGP standard" (USA standard for above ground pools)
- CPSIA "Consumer Product Safety Improvement Act" (USA regulation of consumer and children's products)

- ASTM F2666 "Small pools standard" (USA standard for pools under 36" water depth)
- UL1450 "Electric inflators" (USA standard for electric inflators)
- UL1081 "Swimming pool pumps, filters and chlorinators" (USA standard)
- UL1563 "Electric Spas" (USA standard for Spa)

Intex's Commitment to Excellence extends to helping our environment and supporting the ecosystem. It begins with product design. Intex's filter pumps operate on much lower amps than most filter pumps in the market, reducing electricity consumption. Our saltwater systems clean pools using only natural salt, eliminating the ongoing need for environmentally unfriendly packaged chlorine.

Intex also operates one of the most comprehensive recycling programs in the industry. We are one of the earliest companies in China to successfully obtain a license to ship consumers' returns in the original package back to China to be recycled. Therefore, used materials and product returns are prevented from going to landfills and instead re-used in the manufacturing process where up to 10% of annually produced PVC is recycled.

Intex designs all of our own packaging for our products. We constantly challenge our methods of packaging to improve

efficiency and reduce waste. More compact packaging techniques save cardboard while cutting down on space utilization, saving freight and fuel consumption.

As a manufacturer, Intex knows it has a responsibility to manage the amount of waste produced. As an employer of over ten thousand people, we also encourage our own employees to recycle, reduce waste, and be conscious of the environment. Starting from recycling corners for all our worldwide office facilities, our factory has worked with the local government as well as through sponsorships with key partners to strengthen our efforts to be more eco-friendly. Intex has worked to provide incentives and seminars to employees as well as setting targets to reduce energy consumption. In addition, Intex has made significant investment in technology to achieve these goals. For example, we have implemented a frequency converter system which converts diesel to natural gas, installed solar water heaters and set up a recycled sewage system, and invested in equipment that reduces gas emissions.

From product design, to more efficient processes that save energy and reduce waste, to a world class recycling program, to more energy efficient offices, the people at Intex are striving to provide the best value products anywhere while constantly keeping our global ecosystem in mind.



08	Fiber-Tech™ Technology
10	Dura-Beam® Standard Series
18	Dura-Beam® Plus Series
28	Dura-Beam® Deluxe Series
36	PremAire® Airbeds
44	Multi-Use / Camping
52	Air Furniture
68	Accessories



100% of our products are
quality tested to be air tight
before they leave our factory.

2019





INTRODUCING **FIBER-TECH™** TECHNOLOGY

by **INTEX**

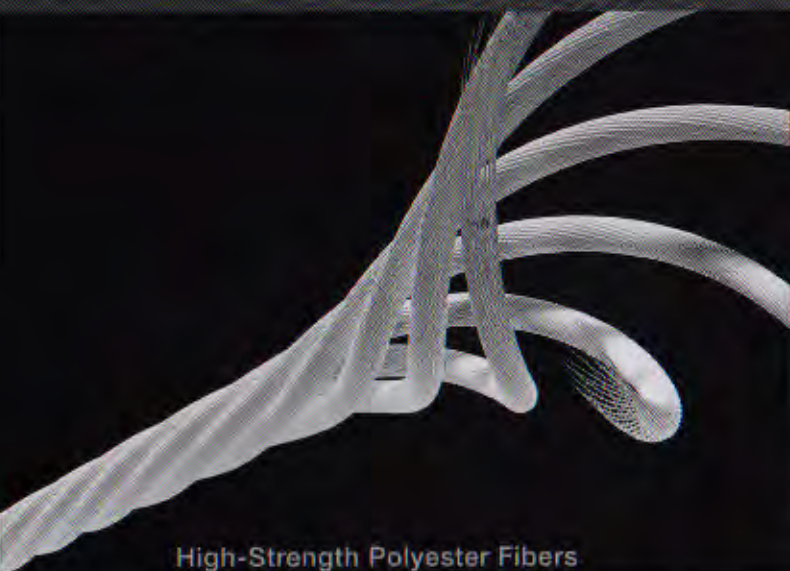

High-Strength Polyester Fibers



Fiber-Tech™ Interior Construction

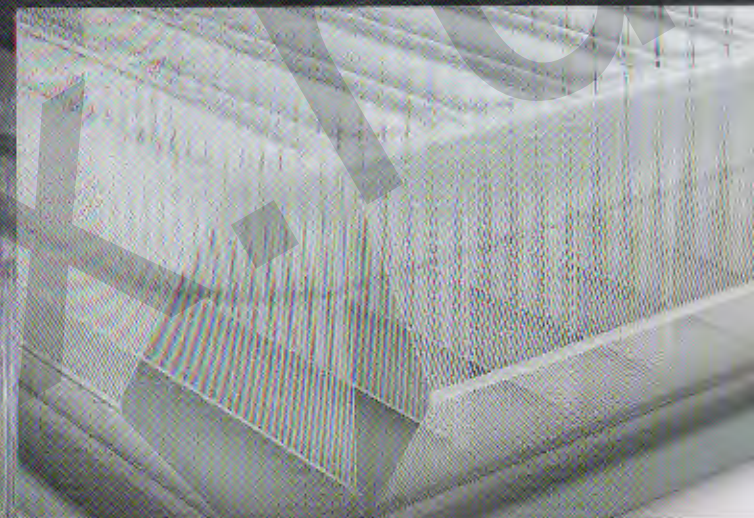

I-Beam Interior Construction

An Incredible Night's Sleep Starts With a Single Thread...

CONTOURED SUPPORT SYSTEM

Our innovative, patented Fiber-Tech™ Technology airbeds are comprised of thousands of high-strength polyester fibers. Unlike traditional airbed construction, these high-strength polyester fibers do not stretch over time, resulting in amazing durability for years of lasting comfort. Fiber-Tech™ interior construction provides the ideal firmness for superb support and rejuvenating sleep.



Designed for Comfort
Engineered for Durability

FIBER-TECH™ TECHNOLOGY

Standard interior construction has been enhanced with lightweight, high-strength fibers for amazing durability and comfort!

U.S. Patent No. 8,562,773 / U.S. Patent No. 9,156,203 /
U.S. Patent No. 9,802,359

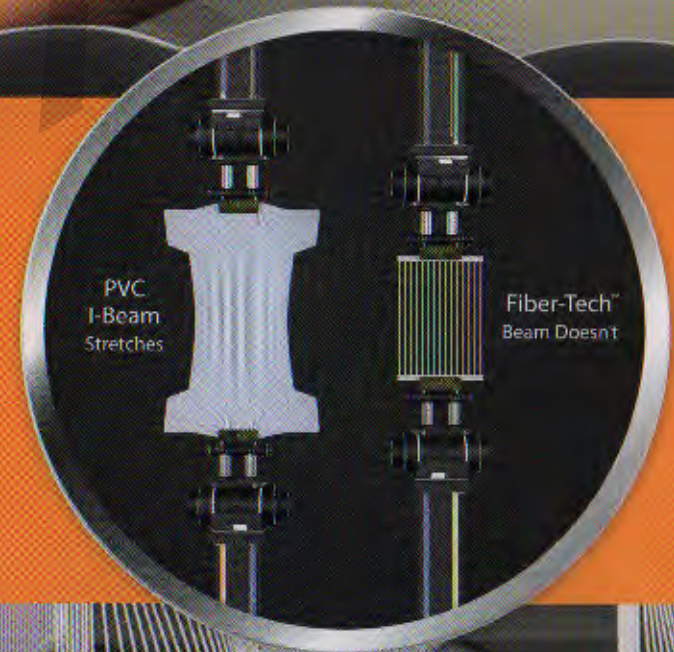



DURA-BEAM[®] STANDARD SERIES



DURABLE
INTERIOR CONSTRUCTION



PORTABLE



**QUICK INFLATION &
DEFLATION**

Great Sleep Made Simple

Our Dura-Beam® Standard airbeds with Fiber-Tech™ Technology are perfect for short-term usage while providing an affordable sleep solution to any indoor or outdoor occasion. Our airbeds feature Fiber-Tech™ interior construction with vertical beams with a bed height ranging from 10 inches to 20 inches high from the floor, making it easy to get in and out. These airbeds are ideal for traveling, camping, and for accommodating overnight guests.

DURA-BEAM® STANDARD SERIES

CLASSIC DOWNY AIRBED

WITH FIBER-TECH™ TECHNOLOGY

NEW

Introducing our updated 10" (25cm) Classic Downy Airbed with Fiber-Tech™ Technology. Versatile and perfect for both in-home and camping, this compact airbed is built for long-lasting durability.



AIRBED ONLY		Approximate Inflated Size	Case Price	Case Weight
64756 / E	Cot Size	30" x 75" x 10" 76cm x 1.91m x 25cm	6 ea	26.9 lb (12.2 kg)
64757 / E	Twin	39" x 75" x 10" 99cm x 1.91m x 25cm	4 ea	24.2 lb (11.0 kg)
64758 / E	Full	54" x 75" x 10" 1.37m x 1.91m x 25cm	3 ea	23.9 lb (10.9 kg)
64759 / E	Queen	60" x 80" x 10" 1.52m x 2.03m x 25cm	3 ea	27.6 lb (12.5 kg)
64765 / E	King	72" x 80" x 10" 1.83m x 2.03m x 25cm	2 ea	30.6 lb (13.9 kg)

AIRBED SET INCLUDES TWO I-BEAM PILLOWS (17" x 11" x 3 1/2" (43cm x 28cm x 9cm)) and a #68912 Double-Quick air pump

		Approximate Inflated Size	Hand Pump	Case Price	Case Weight
64765 / E	Queen	60" x 80" x 10" 1.52m x 2.03m x 25cm	68512	3 ea	31.6 lb (14.4 kg)

INDOOR / OUTDOOR MULTI-USE CLASSIC DOWNY AIRBED

- Fiber-Tech™ Technology
- Quality tested flopped top with vinyl sides and bottom
- Strong and lightweight
- 2-in-1 valve



BEST FOLD

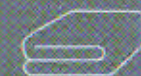

FOLDS COMPACT

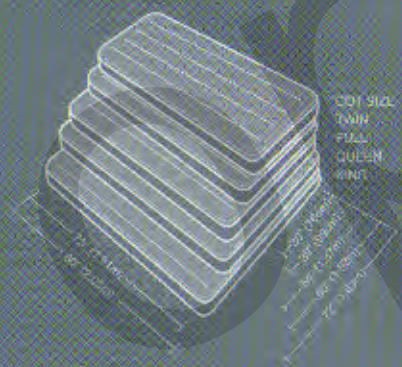

I-BEAM PILLOWS
COT SIZE
TWIN
FULL
QUEEN
KING

10"
25cm

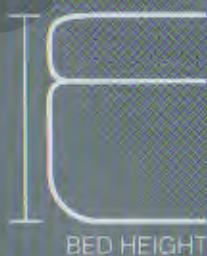

BED HEIGHT



*INFLATION TIME VARIES BY MATTRESS SIZE AND DESIRED FIRMNESS

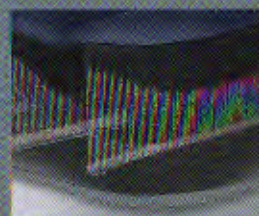

Fiber-Tech™ Technology



2-in-1 valve with extra-wide openings for fast inflating and deflating



Airbed Set (64765/E)

DURA-BEAM® STANDARD SERIES

PILLOW REST CLASSIC AIRBED

WITH FIBER-TECH™ TECHNOLOGY

NEW

Enhanced with Fiber-Tech™ interior construction, our Pillow Rest Classic Airbed is perfect for home or outdoor use. The built-in pillow is designed to provide support and comfort while the plush surface ensures a restful night's sleep.



AIRBED ONLY		Approximate Inflated Size	Case Pack	Case Weight
64141 / E	Twin	39" x 75" x 10" 99cm x 1.91m x 25cm	4 ea.	27.1 lb (12.3 kg)
64142 / E	Full	54" x 75" x 10" 1.37m x 1.91m x 25cm	3 ea.	26.0 lb (11.8 kg)
64143 / E	Queen	60" x 80" x 10" 1.52m x 2.03m x 25cm	3 ea.	31.3 lb (14.2 kg)
64144 / E	King	72" x 80" x 10" 1.83m x 2.03m x 25cm	2 ea.	24.5 lb (11.2 kg)

WITH BUILT-IN ELECTRIC PUMP		Approximate Inflated Size	Built-in Pump	Case Pack	Case Weight
64145EP 64146	Twin	39" x 75" x 10" 99cm x 1.91m x 25cm	110 - 120V 220 - 240V	3 ea.	27.4 lb (12.5 kg) 25.2 lb (11.5 kg)
64147EP 64148	Full	54" x 75" x 10" 1.37m x 1.91m x 25cm	110 - 120V 220 - 240V	3 ea.	33.7 lb (15.3 kg) 34.8 lb (15.8 kg)
64149EP 64150	Queen	60" x 80" x 10" 1.52m x 2.03m x 25cm	110 - 120V 220 - 240V	3 ea.	39.6 lb (18.0 kg) 40.8 lb (18.5 kg)

BUILT-IN COMFORT

- Fiber-Tech™ Technology
- Mattress is raised 10" (25cm) from the floor for convenience
- Built-in pillow for added support and bed-like comfort
- 3-in-1 valve on "Airbed Only" series has extra-wide openings



CARRY BAG



SHelf BOX

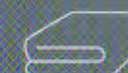

FOLDS COMPACTLY



BUILT-IN AIR PUMP

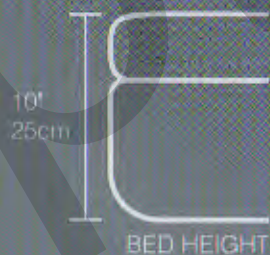
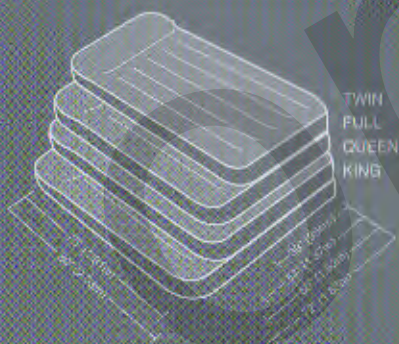

BED HEIGHT

AC Electric Pump	INFLATING TIME*	
	TWIN	QUEEN
TWIN	1 1/2 MINUTES	1 1/2 MINUTES
FULL	2 MINUTES	2 MINUTES
QUEEN	2 1/4 MINUTES	2 1/4 MINUTES

* INFLATING TIME Varies BY MAttRESS SIZE AND DESIRED FIRmNESS

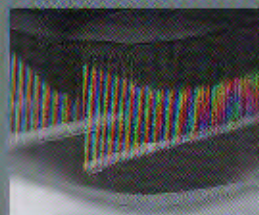

Fiber-Tech™ Technology



Internal Pump
(110 - 120V)



Built-in AC Electric Pump
(220 - 240V)



Built-in pillow for
added convenience

DURA-BEAM® STANDARD SERIES

PILLOW REST MID-RISE AIRBED

WITH FIBER-TECH™ TECHNOLOGY

Introducing the new 12" Pillow Rest Mid-Rise Airbed with Fiber Tech™ Technology. This compact airbed offers the perfect all-around sleeping solution, providing both campers and in-home users with the convenience of a lightweight, comfortable bed that is built for great sleep anywhere you go. This airbed is covered in a soft, velvety sleeping surface for extra comfort. The powerful built-in pump easily inflates and deflates the airbed within minutes. Whether for camping, vacation, or indoor use, this bed is the perfect multi-functional solution.

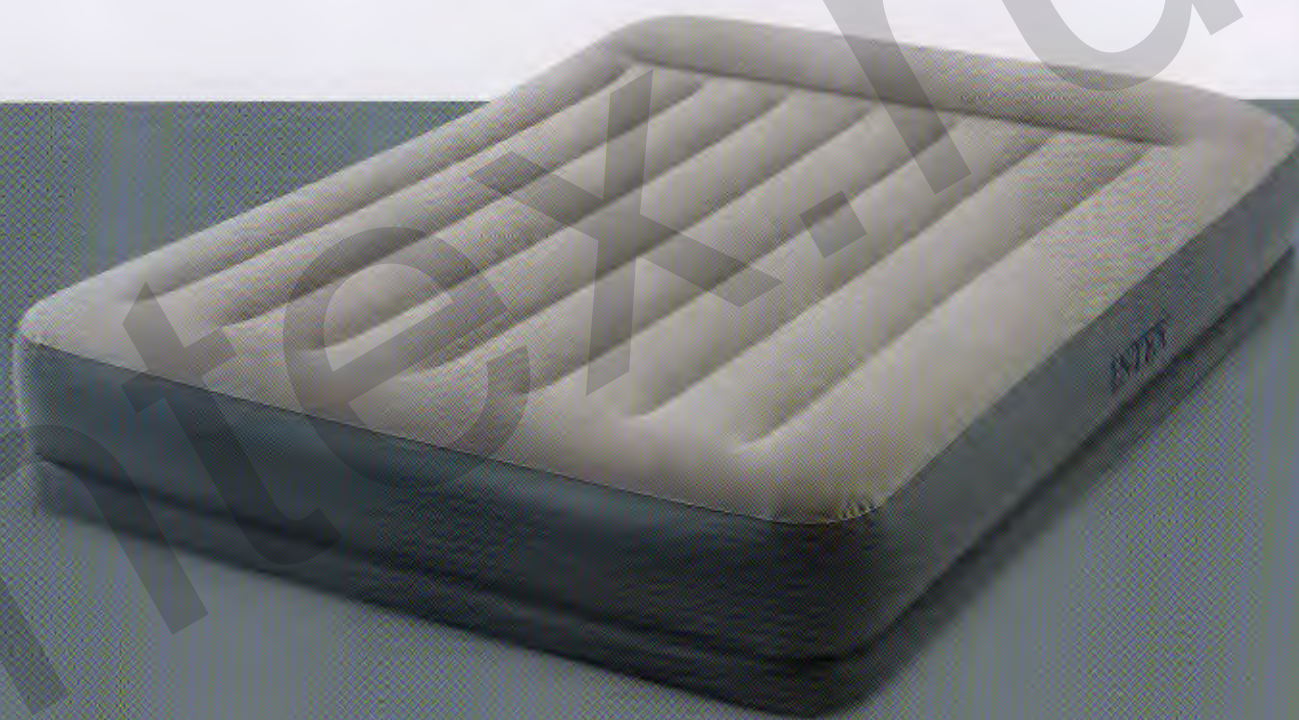

WITH BUILT-IN ELECTRIC PUMP		Approximate Inflated Size	Pack-in Pump	Case Pack	Gross Weight
64115EP 64116	Twin	39" x 75" x 12" 99cm x 1.91m x 30cm	110 - 120V 220 - 240V	3 ea	30.5 lb (13.9 kg) 30.6 lb (13.9 kg)
64117EP 64118	Queen	60" x 80" x 12" 1.52m x 2.03m x 30cm	110 - 120V 220 - 240V	2 ea	29.7 lb (13.5 kg) 29.7 lb (13.5 kg)

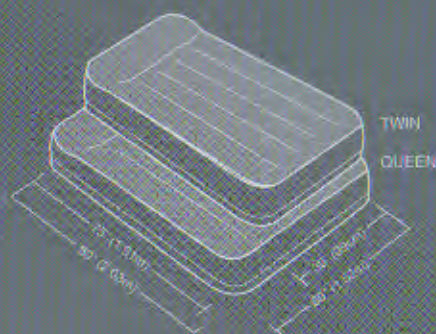

AC Electric Pump W/ 120V/240V	TWIN		QUEEN	
	110V	220V	110V	220V
TWIN	1 3/4 Minutes	1 3/4 Minutes	3 Minutes	3 Minutes
QUEEN	3 Minutes	3 Minutes	3 Minutes	3 Minutes

*INFLATING TIME VARIES BY MATTRESS SIZE AND DESIRED FIRMNESS

ELEVATED FOR CONVENIENCE

- Fiber-Tech™ Technology
- Mattress is raised 12" (30cm) from the floor for convenience
- A built-in pillow provides bed-like comfort



CARRY BAG



STORAGE BOX



FOLDS COMPACTLY



BUILT-IN AIR PUMP*

12"
30cm



BED HEIGHT

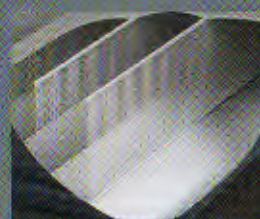

Fiber-Tech™ Technology



Internal Pump
(110 - 120V)



Built-in AC Electric Pump
(220 - 240V)



Built-in pillow for added
convenience

DURA-BEAM® STANDARD SERIES

PILLOW REST RAISED AIRBED

WITH FIBER-TECH™ TECHNOLOGY

Our best-selling Pillow Rest Raised Airbed has been enhanced with Fiber-Tech™ interior construction, providing you added comfort and durability, and an overall better sleeping experience.

WITH BUILT-IN ELECTRIC PUMP		Approximate Inflated Size	Built-in Pump	Case Pack	Case Weight
64121EP 64122	Twin	39" x 75" x 16 1/2" 99cm x 1.91m x 42cm	110 - 120V 220 - 240V	2 ea.	33.5 lb (15.2 kg) 33.5 lb (15.3 kg)
64123EP 64124	Queen	60" x 80" x 16 1/2" 1.52m x 2.03m x 42cm	110 - 120V 220 - 240V	2 ea.	31.5 lb (14.3 kg) 31.7 lb (14.4 kg)

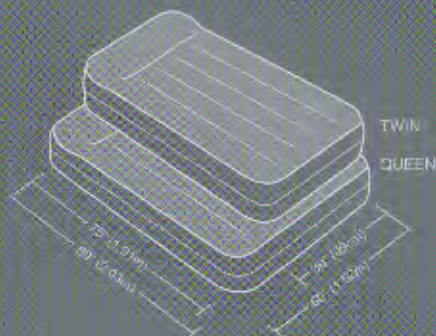

	AC Electric Pump INFLATING TIME*	
	110V	220V
TWIN	2 1/2 hours	2 hours
QUEEN	3 1/2 hours	3 hours

*INFLATING TIME VARIES BY MATTRESS SIZE AND DESIRED FIRMNESS



ELEVATED FOR CONVENIENCE

- Fiber-Tech™ Technology
- Mattress is raised 16 1/2" (42cm) from the floor for convenience
- A built-in pillow provides bed-like comfort



CARRY BAG

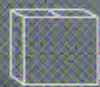

STORE BOX



FOLDS COMPACTLY



BUILT-IN AIR PUMP

16 1/2"
42cm



BED HEIGHT

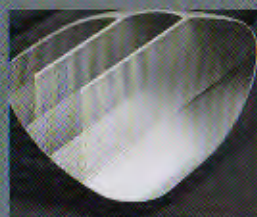

Fiber-Tech™ Technology



Internal Pump
(110 - 120V)



Built-in AC Electric Pump
(220 - 240V)



Built-in pillow for added
convenience

DURA-BEAM® STANDARD SERIES

DELUXE PILLOW REST RAISED AIRBED

WITH FIBER-TECH™ TECHNOLOGY

A deluxe version of our Pillow Rest Raised Airbed! Modified with Fiber-Tech™ interior construction, overnight guests will enjoy the added comfort, support and firmness this mattress brings. The outer perimeter frame on the sleeping surface provides added edge support – making the bed feel roomier and easier to get in and out of.



WITH BUILT-IN ELECTRIC PUMP		Approximate Inflated Size	Air In Pump	Gear Pairs	Gross Weight
64131EP	Twin	39" x 75" x 16 1/2"	110 - 120V	3 ea	38.0 lb (17.3 kg)
64132		99cm x 1.07m x 42cm	220 - 240V		38.0 lb (17.3 kg)
64135EP	Queen	60" x 80" x 16 1/2"	110 - 120V	2 ea	53.8 lb (24.4 kg)
64136		1.52m x 2.03m x 42cm	220 - 240V		53.8 lb (24.4 kg)

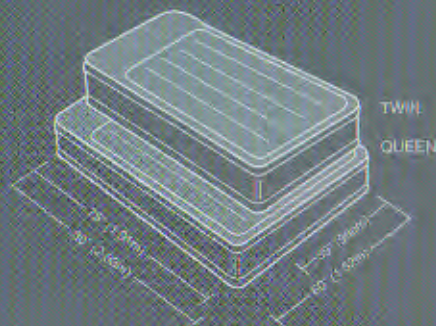

	AC Electric Pump (including hoses)	
	110V*	220V
TWIN	2 1/2 hours	2 hours
QUEEN	3 1/4 hours	3 hours

*INFLATING TIME VARIES BY MATTRESS SIZE AND DESIRED FIRMNESS

BUILT-IN PILLOW AND SOFT FLOCKED TOP FOR COMFORT

- Fiber-Tech™ Technology
- Mattress is raised 16 1/2" (42cm) from the floor for convenience
- Indented sides positioned perfectly to keep fitted sheets firmly in place



CARRY BAG



SHELF BOX



FOLDS COMPACTLY



BUILT-IN AC PUMP

16 1/2"
42cm



BED HEIGHT



Fiber-Tech™ Technology



Internal Pump
(110 - 120V)



Built-in AC Electric Pump
(220 - 240V)



Built-in pillow for added convenience

DURA-BEAM® STANDARD SERIES

ESSENTIAL REST AIRBED

WITH FIBER-TECH™ TECHNOLOGY

Our Essential Rest Airbed with Fiber-Tech™ interior construction features a traditional bed height so guests will feel right at home. Your houseguests will love the better support and firmness Fiber-Tech™ Technology brings. The indented sides help grip fitted sheets. The outer perimeter frame on both top and bottom provides additional stability and support. This full-featured bed is all you need for a great night's sleep.

WITH BUILT-IN ELECTRIC PUMP		Approximate Inflated Size	Built-in Pump	Case Pack	Case Weight
64139EP	Queen	60" x 80" x 20"	110 - 120V	2 ea.	36.9 lb (16.5 kg)
64140		1.52m x 2.03m x 51cm	220 - 240V		35.5 lb (16.6 kg)

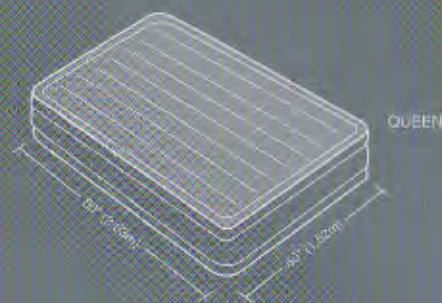

AC Electric Pump (Required Tools)		
	110V	220V
QUEEN	4 MINUTES	3 1/2 MINUTES

* INFLATING TIME VARIES BY MATTRESS SIZE AND DESIRED FIRMNESS



ELEVATED FOR COMFORT & CONVENIENCE

- Fiber-Tech™ Technology
- The Dual-chamber construction provides ample vertical stability
- Mattress is raised 20" (51cm) from the floor for convenience
- Cozy flopped mattress top

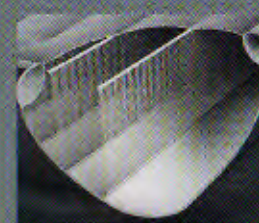
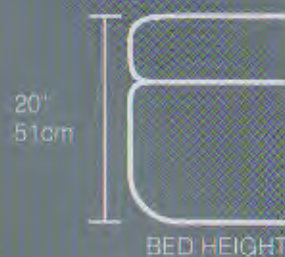

Fiber-Tech™ Technology



Internal Pump (110 - 120V)



Built-in AC Electric Pump (220 - 240V)



DURA-BEAM[®] PLUS SERIES



DURABLE
INTERIOR CONSTRUCTION



COMFORTABLE SURFACE

The sleep you've always dreamed of ... Isn't a dream at all

Our Dura-Beam® Plus airbeds are the perfect sleep solution for overnight guests to ensure sweet dreams. This enhanced line features luxurious flocked and pillow top surfaces, with Fiber-Tech™ interior construction for superb structural stability and support. These luxurious beds are all you need for a great night's sleep.



BUILT-IN ELECTRIC PUMP
WITH HAND PUMP OPTION
Except 64707/E, 64708/E, 64709/E



HIGH RISE
FOR REAL BEDLIKE EXPERIENCE



Dura-Beam® Airbed



Traditional Airbed

DURA-BEAM® PLUS SERIES

DELUXE SINGLE-HIGH

AIRBED WITH FIBER-TECH™ TECHNOLOGY

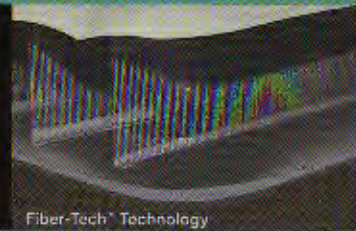

Introducing 10' (25cm) Deluxe Single-High Airbed with Fiber-Tech™ Technology. The perfect all-around sleeping solution, this compact airbed provides both campers and in-home users with the convenience of a low-profile, light-weight, comfortable bed that is built for long-lasting durability.

This airbed is covered in a soft, flocked sleeping surface for enhanced comfort. Our patented Fiber-Tech™ interior construction provides superb support and structural stability for a restful night's sleep. Made for durability and comfort, anywhere you go.

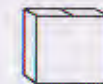
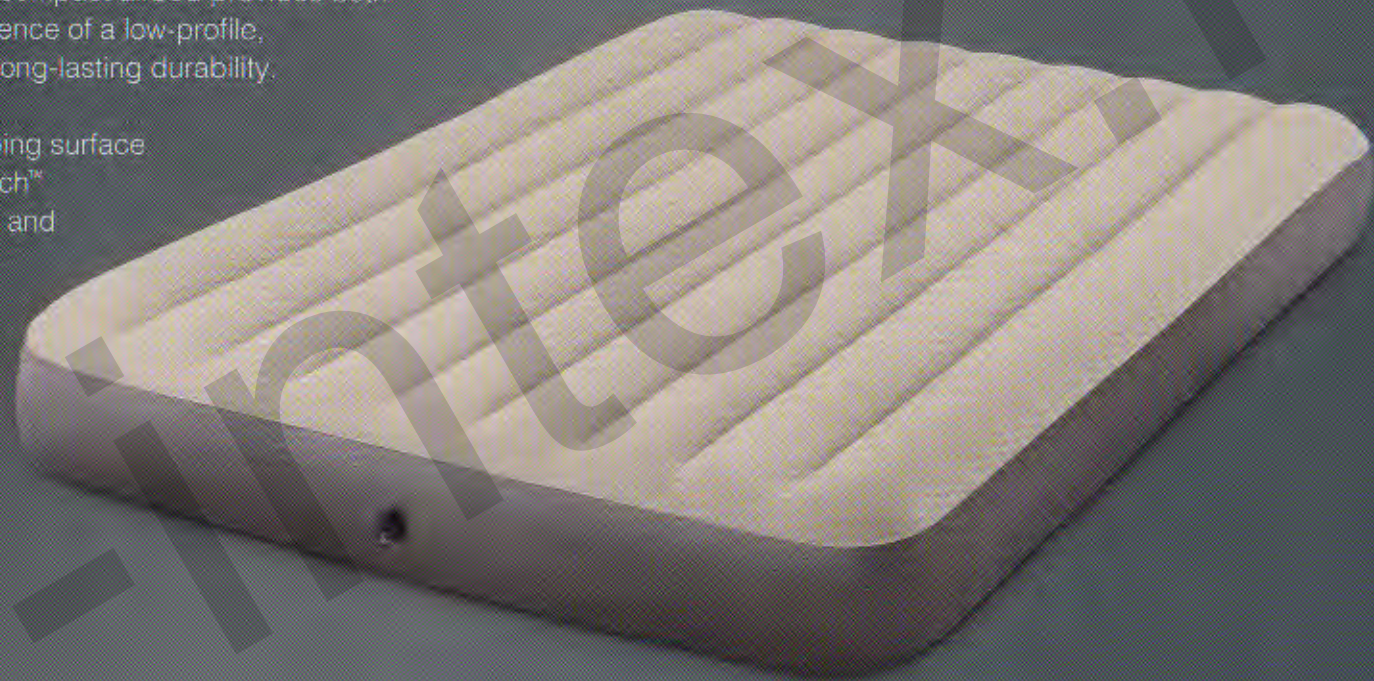

SHIPS IN BOX



FOLDS COMPACTLY

INDOOR / OUTDOOR MULTI-USE SINGLE-HIGH AIRBED

- Fiber-Tech™ Technology
- Quality tested flocked top and sides with vinyl bottom
- Strong and lightweight
- 2-in-1 valve

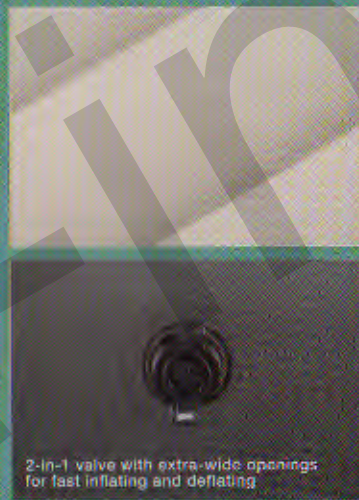
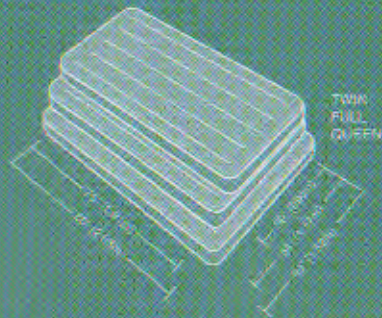

2-in-1 valve with extra-wide openings for fast inflating and deflating



AIRBED ONLY	Approximate Inflated Size	Case Pack	Case Weight
64707 / E Twin	39" x 75" x 10" 99cm x 1.91m x 25cm	4 ea	23.9 lb (10.9 kg)
64708 / E Full	54" x 75" x 10" 1.37m x 1.91m x 25cm	3 ea	23.8 lb (10.8 kg)
64709 / E Queen	60" x 80" x 10" 1.52m x 2.03m x 25cm	3 ea	27.6 lb (12.5 kg)

DURA-BEAM® PLUS SERIES

COMFORT-PLUSH AIRBED

WITH FIBER TECH™ TECHNOLOGY

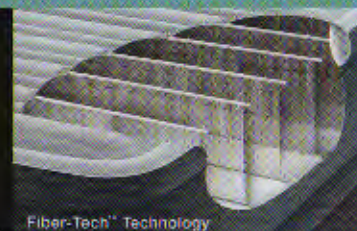

Our most popular bed in the Dura-Beam® series with three different bed heights to choose from, our Comfort-Plush Airbeds offer the perfect combination of luxurious comfort and convenience.

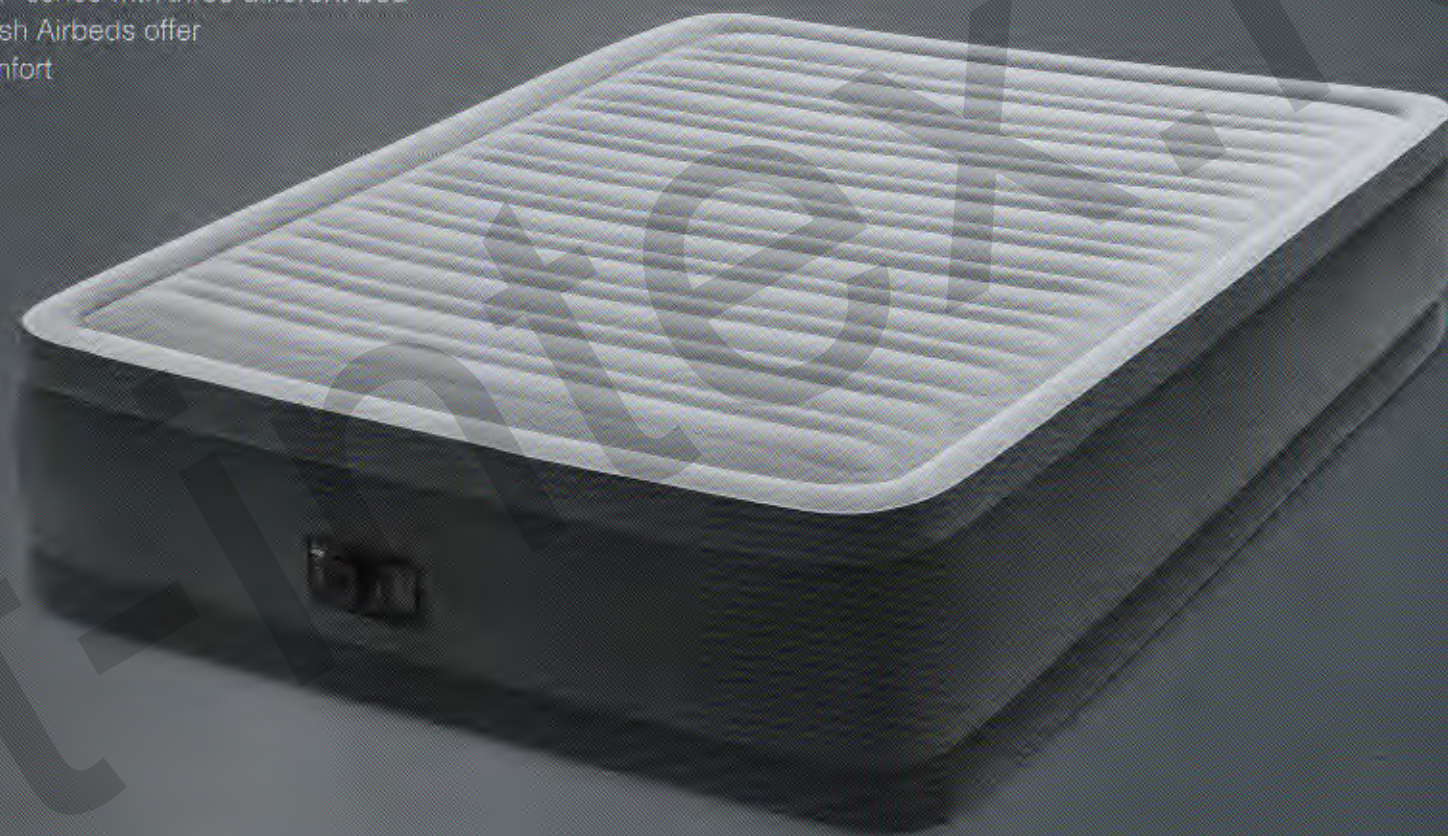

CARRY BAG



SOFT STORAGE BOX



FOLDS COMPACTLY

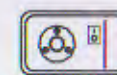

BUILT IN AIR PUMP

COMFORT-PLUSH HORIZONTAL BEAM AIRBED

- Fiber-Tech™ Technology
- Quality tested flocked top and sides with vinyl bottom

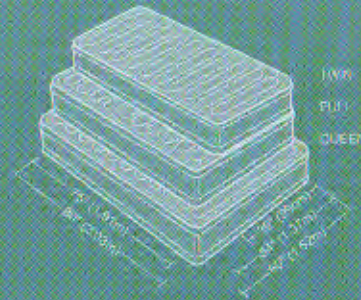

TWIN
FULL
QUEEN

AC Electric Pump Inflating Time*		
	TWIN	QUEEN
TWIN	2 Minutes	2 Minutes
FULL	3 Minutes	3 Minutes
QUEEN	3 Minutes	3 Minutes

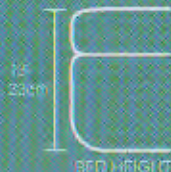

AC Electric Pump Inflating Time*		
	TWIN	QUEEN
TWIN	2 Minutes	2 Minutes
QUEEN	4 Minutes	4 Minutes



*INFLATING TIME VARIES BY DESIRED FIRMNESS.

*INFLATING TIME VARIES BY DESIRED FIRMNESS.

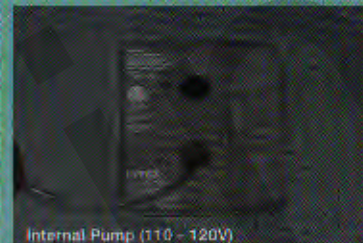
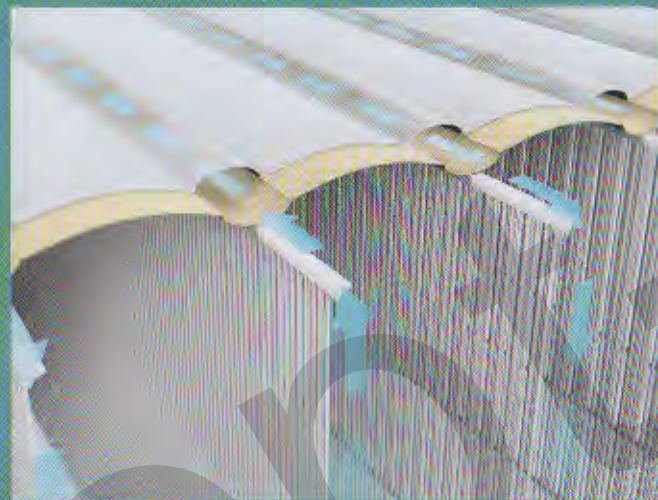

Internal Pump (110 - 120V)

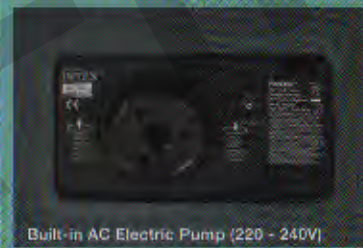

Built-in AC Electric Pump (220 - 240V)



WITH BUILT-IN ELECTRIC PUMP		Approximate Inflated Size	Built-in Pump	Case Pack	Case Weight
67765EP 67766	Twin	39" x 75" x 13" 99cm x 1.91m x 33cm	110 - 120V 220 - 240V	3 ea	40.5 lb (18.4 kg) 39.8 lb (18.1 kg)
67767EP 67768	Full	54" x 75" x 13" 1.37m x 1.91m x 33cm	110 - 120V 220 - 240V	2 ea	33.1 lb (15.0 kg) 32.4 lb (14.7 kg)
67769EP 67770	Queen	60" x 80" x 13" 1.52m x 2.03m x 33cm	110 - 120V 220 - 240V	2 ea	37.2 lb (16.9 kg) 36.7 lb (16.7 kg)

WITH BUILT-IN ELECTRIC PUMP		Approximate Inflated Size	Built-in Pump	Case Pack	Case Weight
64411EP 64412	Twin	39" x 75" x 18" 99cm x 1.91m x 46cm	110 - 120V 220 - 240V	3 ea	44.5 lb (20.2 kg) 45.2 lb (20.5 kg)
64413EP 64414	Queen	60" x 80" x 18" 1.52m x 2.03m x 46cm	110 - 120V 220 - 240V	2 ea	41.3 lb (18.8 kg) 40.9 lb (18.6 kg)

DURA-BEAM® PLUS SERIES

COMFORT-PLUSH AIRBED

WITH FIBER-TECH™ TECHNOLOGY



Each bed is covered in plush flocking that is soft to the touch, and the horizontal air chambers provide added stability and support around the entire bed. For extra convenience, this bed comes with a powerful built-in electric pump for fast inflation and deflation.



CARRY BAG



SHELF BOX

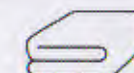

FOLDS COMPACTLY

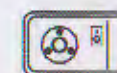

BUILT IN AIR PUMP

COMFORT-PLUSH HORIZONTAL BEAM AIRBED

- Fiber-Tech™ Technology
- Quality tested flocked top and sides with vinyl bottom

AC Electric Pump No 14000 Series	110V	120V
	QUEEN	4 1/2 Hours

* INFLATING TIME VARIES BY DESIRED FIRMNESS

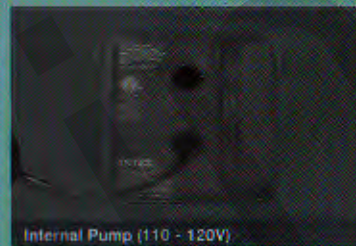
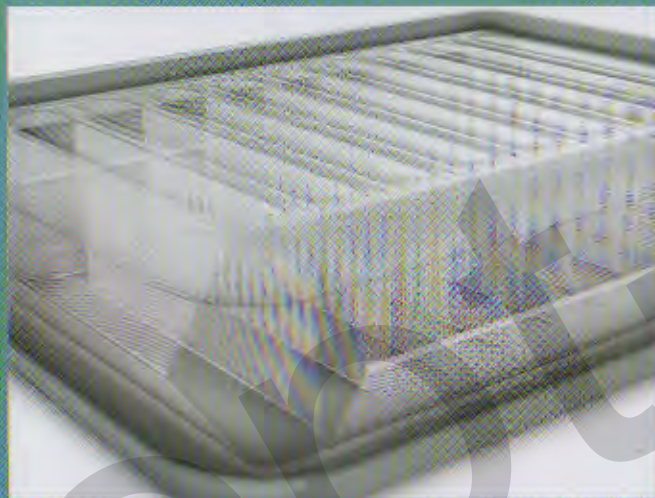
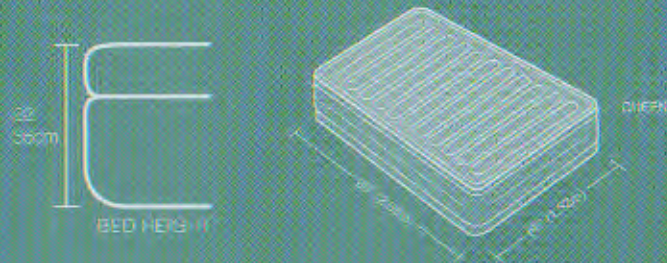

WITH BUILT-IN ELECTRIC PUMP		Approximate Inflated Size	Built-in Pump	Case Pack	Case Weight
64417EP	Queen	60" x 80" x 22"	110 - 120V	2 ea	45.7 lb (20.8 kg)
64418		1.52m x 2.03m x 56cm	220 - 240V		46.7 lb (21.2 kg)

DURA-BEAM® PLUS SERIES

ULTRA PLUSH AIRBED

WITH FIBER-TECH™ TECHNOLOGY

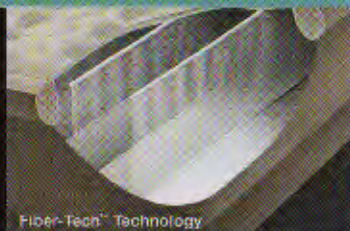

Here's an airbed that is sure to impress your most important guests: The Ultra Plush Airbed is designed with revolutionary Fiber-Tech™ Technology. This raised bed combines comfort, convenience, and great appearance into one luxurious airbed, with its unique textured sleeping surface and inflated outer perimeter band for superior stability, comfort and support.



CARRY BAG



SHelf BOX



FOLDS COMPACTLY

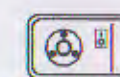

BUILT IN AIR PUMP

ELEVATED WITH BUILT-IN ELECTRIC PUMP

- Fiber-Tech™ Technology
- Textured pillow top for added comfort
- 18" (46cm) Raised height
- Built-in pump for rapid inflation and deflation

AC Electric Pump (included)		110V	240V
TWIN	2 1/2 Mins	2 Mins	
QUEEN	4 Mins	3 1/2 Mins	

*INFLATING TIME VARIES BY DESIRED FIRMNESS

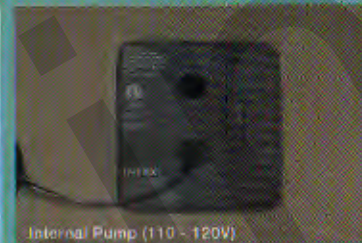
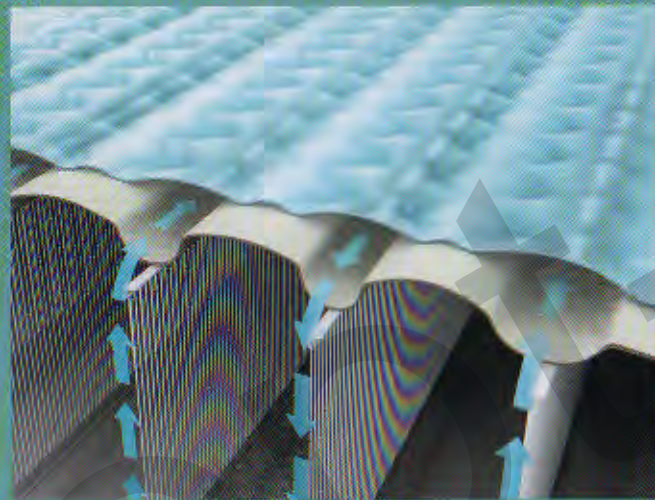
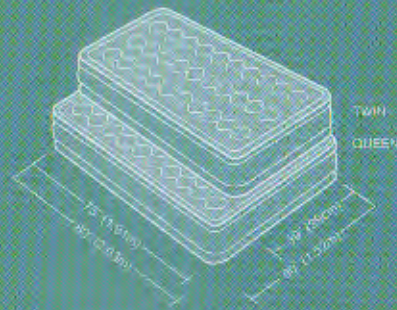

U.S. Patent No. 6,568,011

WITH BUILT-IN ELECTRIC PUMP		Approximate Inflated Size	Built-in Pump	Case Pack	Case Weight
64455EP	Twin	39" x 75" x 18" 99cm x 1.91m x 46cm	110 - 120V	2 ea	30.3 lb (13.8 kg)
64456			220 - 240V		30.1 lb (13.7 kg)
64457EP	Queen	60" x 80" x 18" 1.52m x 2.03m x 46cm	110 - 120V	2 ea	41.0 lb (18.6 kg)
64458			220 - 240V		40.3 lb (18.3 kg)

Wake up to a whole new you

Our Dura-Beam® Deluxe airbeds are designed for the ultimate sleep experience. This elite line features Fiber-Tech™ interior construction for superb structural stability and support, with enhanced sleeping surfaces – fleece top or pillow top. The elevated bed heights range from 18 inches to 20 inches, allowing guests to easily get in and out of bed. For added convenience, the powerful built-in pump easily inflates and deflates the airbed within minutes. Wake up feeling refreshed with our Dura-Beam® Deluxe airbeds.

DURA-BEAM® DELUXE SERIES



DURABLE
INTERIOR CONSTRUCTION



COMFORTABLE SURFACE



opt.ru



BUILT-IN ELECTRIC PUMP
WITH HAND PUMP OPTION



HIGH RISE
FOR REAL BEDLIKE EXPERIENCE



Dura-Beam® Airbed



Traditional Airbed

DURA-BEAM® DELUXE SERIES

PRIME COMFORT ELEVATED

AIRBED WITH FIBER TECH™ TECHNOLOGY

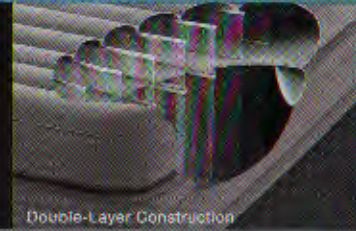

Introducing our 20" Prime Comfort Elevated Airbed with Fiber-Tech™ Technology, the perfect all around sleeping solution with an enhanced soft, fleece flocked top. The double layered construction allows you to tuck in standard size queen bed sheets easily and securely. Our patented Fiber-Tech™ interior construction provides superb support and structural stability for restful night sleep. For added convenience the powerful built-in pump easily inflates and deflates the airbed within minutes.



CARRY BAG



SHELF BOX

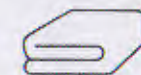

FOLDS COMPACTLY

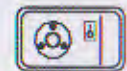

BUILT IN AIR PUMP

ELEVATED WITH BUILT-IN ELECTRIC PUMP

- Fiber-Tech™ Technology
- 20" (51cm) Raised height
- Double Layered construction

AC Electric Pump INFLATING TIMES*		
	110V	220V
TWIN	2 1/2 hours	2 hours
QUEEN	4 hours	3 1/2 hours

*INFLATING TIME VARIES BY DESIRED FIRMNESS

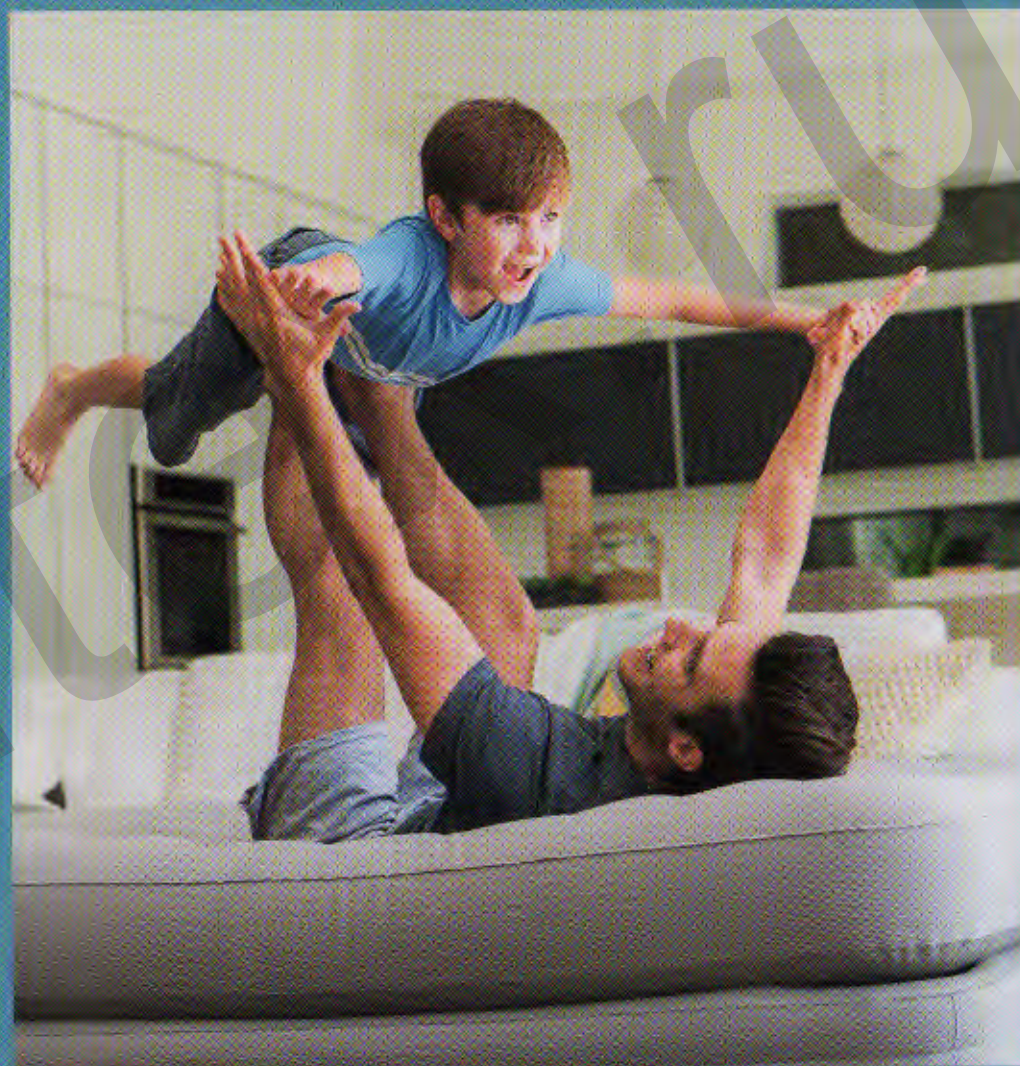
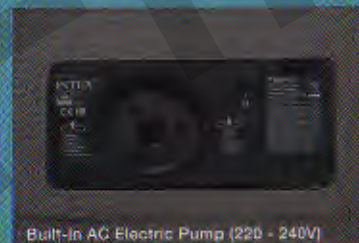
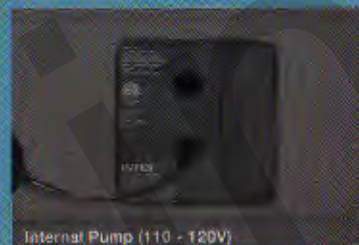
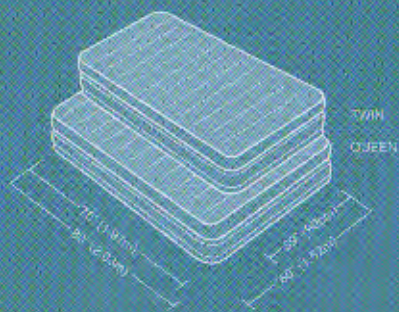

WITH BUILT-IN ELECTRIC PUMP		Approximate Inflated Size	Built-in Pump	Case Pack	Case Weight
64443EP	Twin	39" x 75" x 20"	110 - 120V	2 ea	36.2 lb (16.5 kg)
64444		99cm x 1.91m x 51cm	220 - 240V		36.5 lb (16.6 kg)
64445EP	Queen	60" x 80" x 20"	110 - 120V	1 ea	25.8 lb (11.7 kg)
64446		1.52m x 2.03m x 51cm	220 - 240V		25.3 lb (11.5 kg)

DURA-BEAM® DELUXE SERIES

SUPREME AIR-FLOW™

AIRBED WITH I FIBER-TECH™ TECHNOLOGY

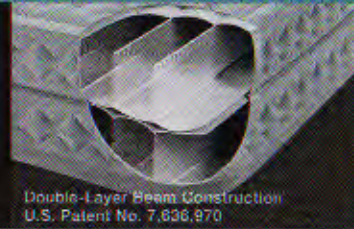

Our Supreme Air-Flow™ Airbed is engineered to provide luxurious, ultimate comfort. A network of inter-connected air pockets on the top and sides of the bed cause the air to flow smoothly and gradually across the sleeping surface for unbelievable comfort and stability. The dual chamber construction provides firm support and allows for fitted sheets to tuck in easily.



CARRY BAG



SHelf BOX



FOLDS COMPACTLY

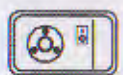

BUILT IN AIR PUMP

ELEVATED WITH BUILT-IN ELECTRIC PUMP

- Fiber-Tech™ Technology
- 20" (51cm) Raised height
- Plush Velvetaire™ pillow top mattress surface
- Inflated bed fits standard sheets
- Network of inter-connected air pockets that allow air to flow smoothly and gradually across the top and side surfaces

AC Electric Pump Inflating Time*		
	110V	220V
TWIN	3 Minutes	2½ Minutes
QUEEN	4½ Minutes	4 Minutes

*INFLATING TIME VARIES BY DESIRED FIRMNESS

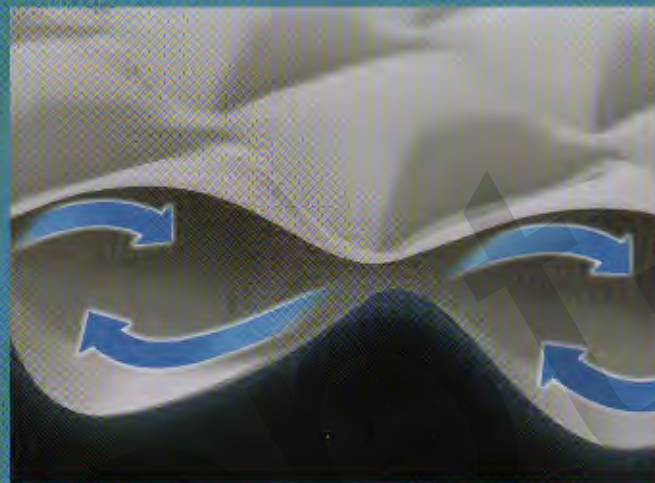
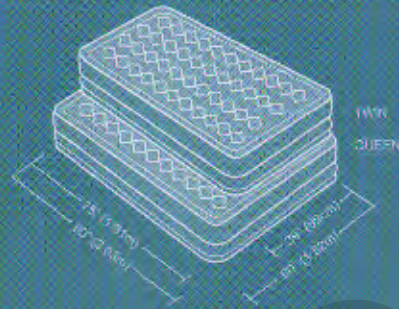
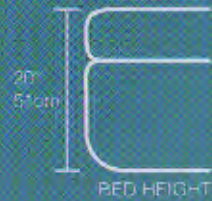

WITH BUILT-IN ELECTRIC PUMP		Approximate Inflated Size	Built-in Pump	Case Pack	Case Weight
64461EP	Twin	39" x 75" x 20"	110 - 120V	1 ea	24.5 lb (11.2 kg)
64462		99cm x 1.91m x 51cm	220 - 240V		24.6 lb (11.2 kg)
64463EP	Queen	60" x 80" x 20"	110 - 120V	1 ea	34.3 lb (15.6 kg)
64464		1.52m x 2.03m x 51cm	220 - 240V		34.4 lb (15.7 kg)

U.S. Patent No. 7,591,036 and U.S. Patent No. 7,406,736

DURA-BEAM® DELUXE SERIES

ULTRA PLUSH HEADBOARD

AIRBED WITH FIBER-TECH™ TECHNOLOGY



Experience a cozy and comfortable night's sleep with the new Dura-Beam® Series Headboard Bed. The functional built-in headboard provides back support when lounging or watching T.V. It can also be used as a pillow stopper when sleeping, keeping your pillows from falling on the floor. The pillow top surface provides a cushioned feel for maximum comfort.



CARRY BAG



SHelf BOX



FOLDS COMPACTLY

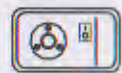

BUILT IN AIR PUMP

ELEVATED WITH BUILT-IN ELECTRIC PUMP

- Fiber-Tech™ interior construction
- Headboard keeps your pillows from falling off the bed throughout the night, and provides support when sitting up
- 18" (46cm) height provides easier access onto and off of the bed
- Quality tested flocked top and sides with vinyl bottom
- Pillow top surface delivers exceptional comfort

AC Electric Pump INFLATING TIMES	110V	240V
	QUEEN 5 Minutes	5 Minutes

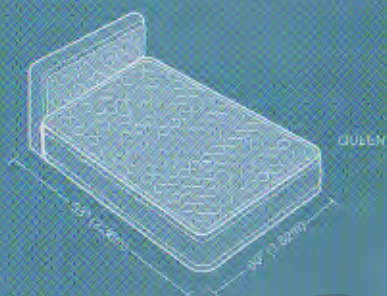

*INFLATING TIME VARIES BY DESIRED FIRMNESS

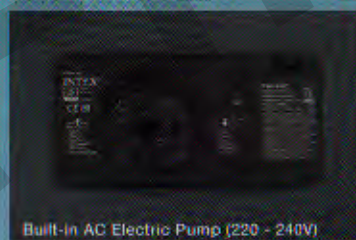
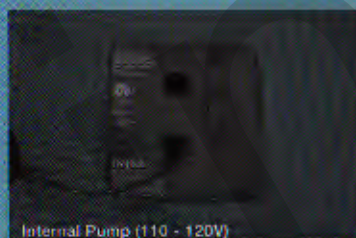

NEW

U.S. Patent No. 6,568,011

WITH BUILT-IN ELECTRIC PUMP	Approximate Inflated Size	Built-in Pump	Case Pack	Case Weight
64447EP 64448	Queen 60" x 93" x 34" 1.52m x 2.36m x 86cm	110 - 120V 220 - 240V	1 ea	27.0 lb (12.3 kg) 26.9 lb (12.2 kg)

A NEW DIMENSION OF LUXURY

PremAire®

Elevated Series with Fiber-Tech™ Technology

Our luxurious, innovative PremAire® line is expanded with exciting new additions.

All PremAire® airbeds are built with our patented and award winning Fiber-Tech™ Technology, offering superb structural stability and support. The high strength fibers provide an interior with amazing durability and unmatched comfort. Each PremAire® mattress is covered in either a pillow top or Microcell™ contour top, ensuring true comfort and promises a great night's sleep. The laminated PVC exterior provides a high quality puncture resistant surface that offers unrivaled resilience and durability.

The bed's elevated height makes it easier to get in and out of each morning. For extra convenience, this bed comes with a powerful built-in electric pump for fast inflation and deflation. Our revolutionary PremAire® mattress offers the perfect combination of luxurious comfort and best-in-class durability.



INTEX®

PremAire®

AIRBED WITH FIBER-TECH TECHNOLOGY

Luxurious flocked pillow top with heavy duty 2-ply laminated side walls and bottom



100% QUALITY TESTED

100% of our airbeds are quality tested to be air tight before they leave our factory

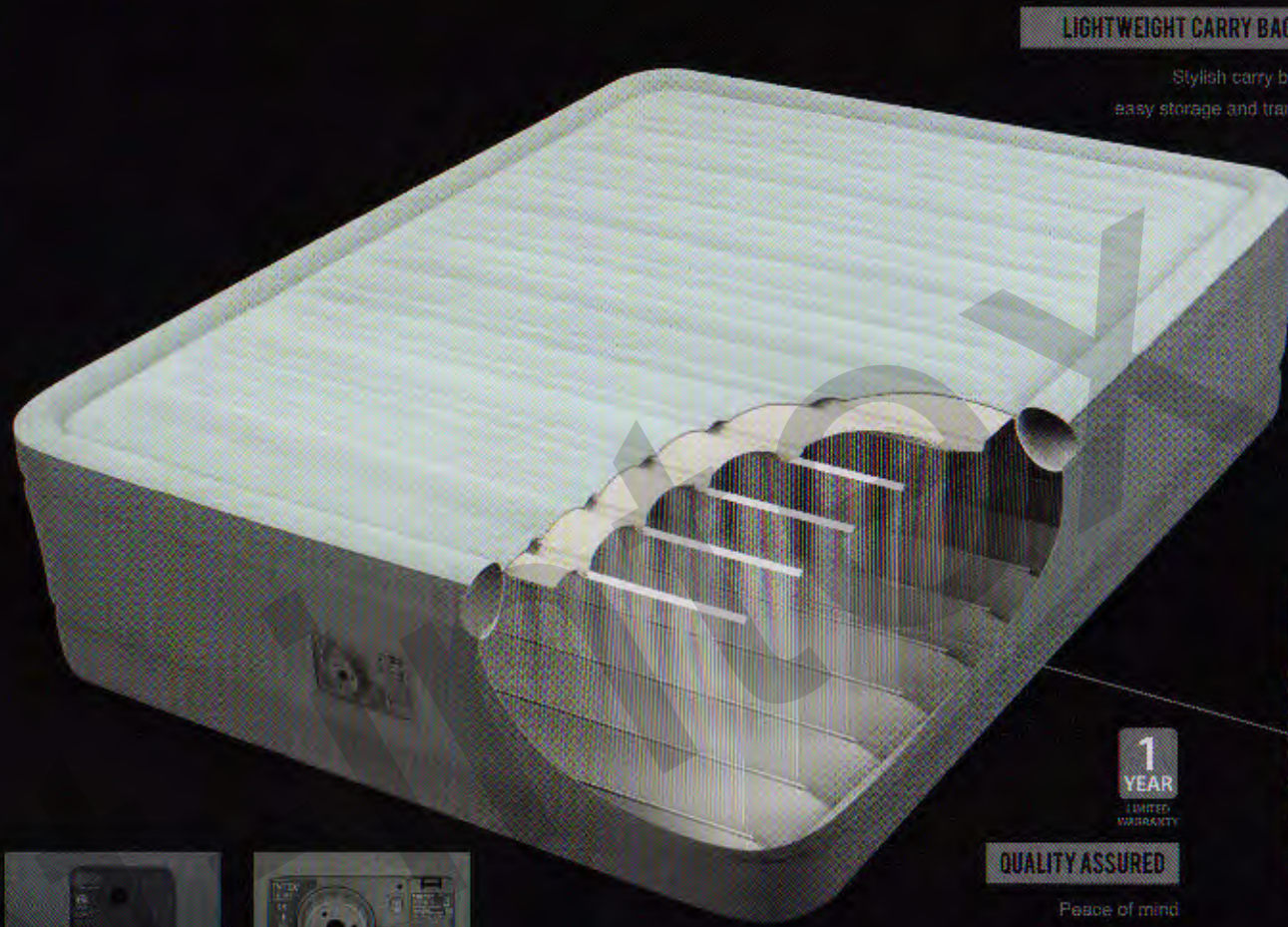
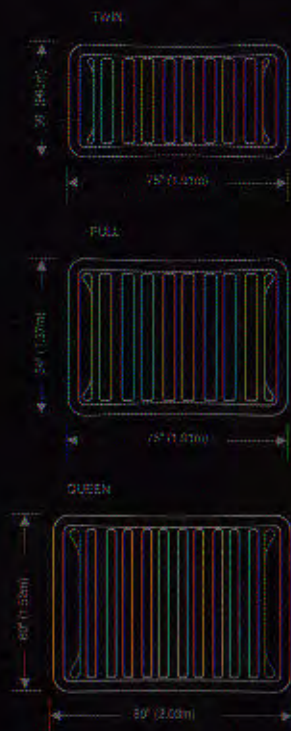

LIGHTWEIGHT CARRY BAG

Stylish carry bag for easy storage and transport

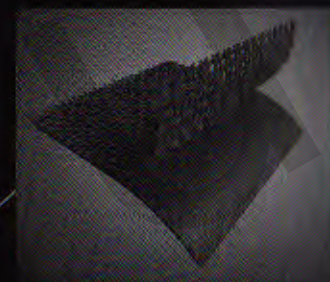

HEAVY DUTY 2-PLY MATERIAL

The 2-ply laminated side walls and bottom firmly retain air while providing a high quality puncture-resistant surface

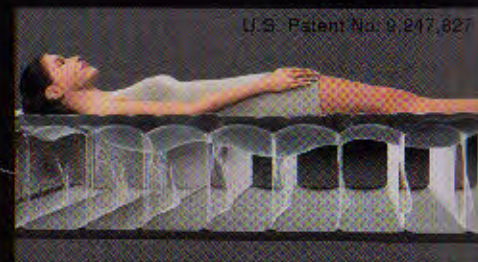

1 YEAR
LIMITED WARRANTY

QUALITY ASSURED

Peace of mind
1 year warranty

REVOLUTIONARY FIBER-TECH™ TECHNOLOGY

Revolutionary, patented Fiber-Tech™ support system provides the perfect combination of superb structural stability and support



Internal Pump
(110 - 120V)



Built-in AC Electric Pump
(220 - 240V)

Item	Size	Approximate Inflated Size	Built-in Pump	Case Pack	Case Weight
64901EP 64902	Twin	39" x 75" x 18" 99cm x 1.91m x 46cm	110-120V 220-240V	2 ea	29.2 lb (13.3 kg) 29.8 lb (13.5 kg)
64903EP 64904	Full	54" x 75" x 18" 1.37m x 1.91m x 46cm	110-120V 220-240V	2 ea	35.8 lb (16.3 kg) 36.2 lb (16.5 kg)
64905EP 64906	Queen	60" x 80" x 18" 1.52m x 2.03m x 46cm	110-120V 220-240V	2 ea	40.2 lb (18.3 kg) 40.5 lb (18.4 kg)

18in
Bed Height

INFLATING TIMES*

AC Electric Pump

Twin	2½ minutes
Full	3½ minutes
Queen	4 minutes

* Inflating time varies by mattress size and desired firmness

Luxurious flocced pillow top with heavy duty 2-ply laminated side walls and bottom

INFLATING TIMES*

AC Electric Pump

Queen 45 minutes

*Inflating time varies by mattress size and desired firmness

18in

Bed Height

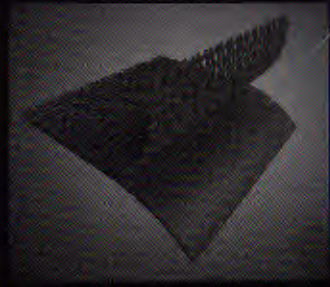

HEAVY DUTY 2-PLY MATERIAL

The 2-ply fully laminated airbed firmly retains air while providing a perfect combination of superior durability, firmness, and comfort.

1
YEAR
LIMITED
WARRANTY

QUALITY ASSURED

Peace of mind
1 year warranty



100% QUALITY TESTED

100% of our airbeds are quality tested to be air tight before they leave our factory

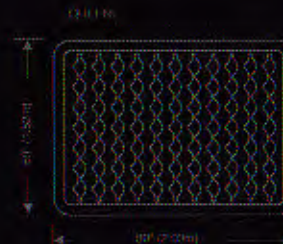

LIGHTWEIGHT CARRY BAG

Stylish carry bag for easy storage and transport

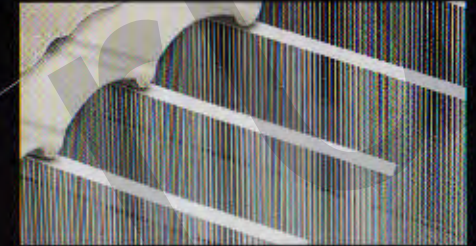

REVOLUTIONARY FIBER-TECH™ TECHNOLOGY

Revolutionary, patented Fiber-Tech™ support system provides the perfect combination of superb structural stability and support



DIGITAL COMFORT PUMP

Newly designed pump panel with firmness control dial and USB port (Patent pending)



BUILT-IN STORAGE WITH 2-IN-1 VALVE

Convenient storage for cord and small personal items.
2-in-1 Valve included for easy inflation and deflation with manual pump. Ideal for outdoor use.

Item	Size	Approximate Inflated Size	Built-in Pump	Case Pack	Case Weight
64925EP	Queen	60" x 80" x 18"	110-120V	2 ea	45.1 lb (20.5 kg)
64926		1.52m x 2.03m x 46cm	220-240V		45.1 lb (20.5 kg)

PremAire®
Dream Support™

AIRBED WITH FIBER-TECH TECHNOLOGY

THE MOST INNOVATIVE AIRBED TECHNOLOGY

Six sided heavy duty 2-ply all laminated Dream Support Airbed



REVOLUTIONARY FIBER-TECH™ TECHNOLOGY

Revolutionary patented Fiber-Tech™ support system provides the perfect combination of superb structural stability and support.

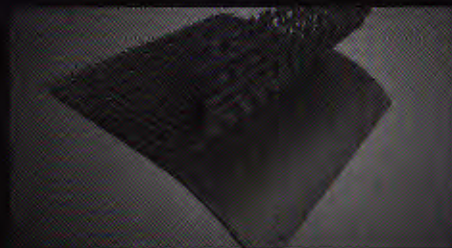

HEAVY DUTY 2-PLY MATERIAL

The 2-ply fully laminated airbed firmly retains air while providing a perfect combination of superior durability, firmness, and comfort.



BUILT-IN STORAGE WITH 2-IN-1 VALVE

Convenient storage for cord and small personal items. 2-in-1 Valve included for easy inflation and deflation with manual pump. Ideal for outdoor use.

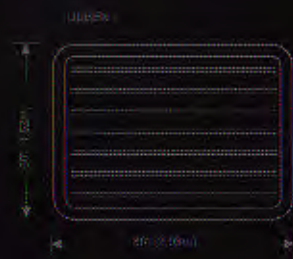
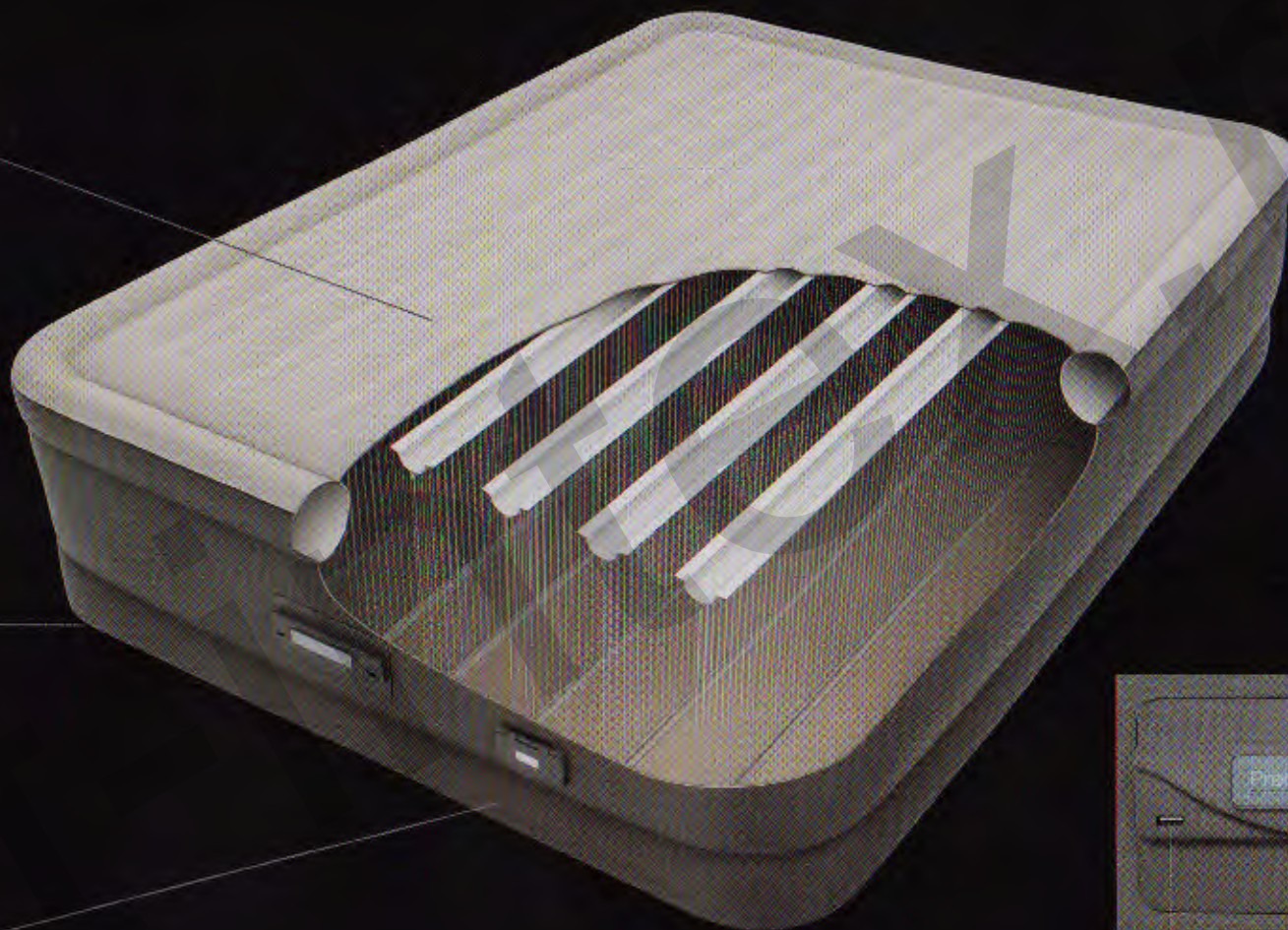

100% QUALITY TESTED

100% of our airbeds are quality tested to be air tight before they leave our factory.

LIGHTWEIGHT CARRY BAG

Stylish carry bag for easy storage and transport.

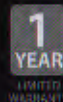

QUALITY ASSURED

Peace of mind. 1 year warranty.



Auto inflate and deflate button

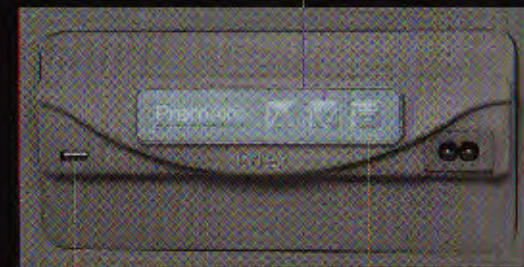

USB connection for charging



Firmness control button

DIGITAL COMFORT PUMP

Newly designed pump panel with firmness control dial and USB port (Patent pending).



18in

Bed Height

INFLATING TIMES*

AC Electric Pump

Queen 4½ minutes

*Inflating time varies by mattress size and desired firmness.

Item	Size	Approximate Inflated Size	Built-in Pump	Case Pack	Case Weight
64769EP	Queen	60" x 80" x 18"	110-120	1 ea	20.1 lb (9.1 kg)
64770		1.52m x 2.03m x 46cm	220-240		20.0 lb (9.1 kg)

Innovative Microcell™ contour top with flocked sides

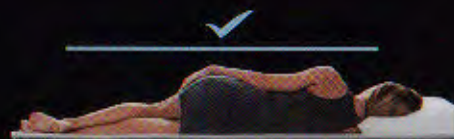

Dura-Beam® Airbed



Traditional Airbed

REVOLUTIONARY FIBER-TECH™ TECHNOLOGY

Revolutionary, patented Fiber-Tech™ support system provides the perfect combination of superb structural stability and support.



BUILT-IN STORAGE WITH 2-IN-1 VALVE

Convenient storage for cord and small personal items. 2-in-1 Valve included for easy inflation and deflation with manual pump. Ideal for outdoor use.

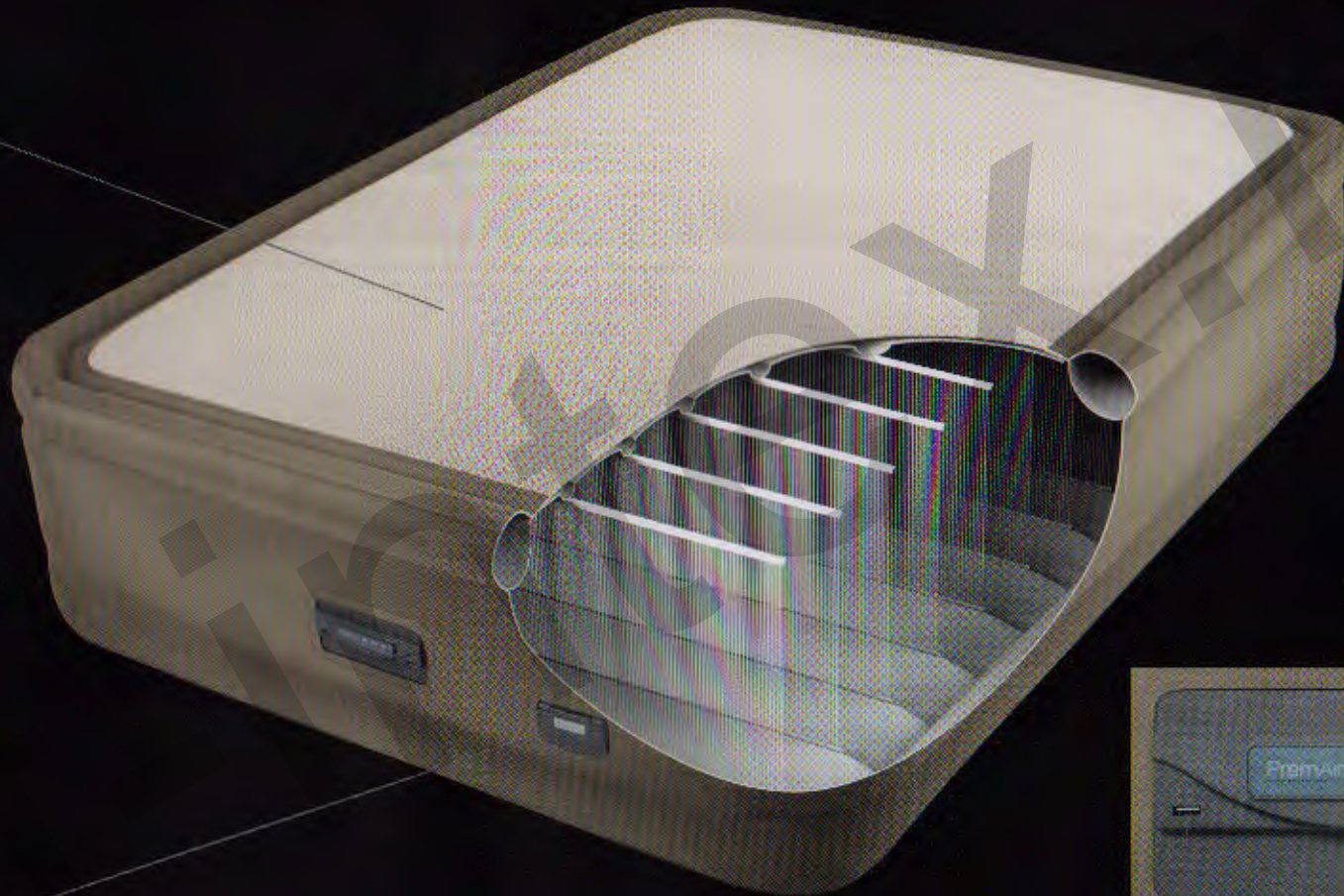

100% QUALITY TESTED

100% of our airbeds are quality tested to be air tight before they leave our factory

LIGHTWEIGHT CARRY BAG

Stylish carry bag for easy storage and transport

1
 YEAR
 LIMITED
 WARRANTY

QUALITY ASSURED

Peace of mind
 1 year warranty



Auto inflate and deflate button



USB connection for charging



Firmness control button





DIGITAL COMFORT PUMP

Newly designed pump panel with firmness control dial and USB port (Patent pending)

MICROCELL™ CONTOUR TOP

Warm when Cool. Cool when Warm.



- 
breathable
- 
warms
- 
wicks
- 
contours

The extra soft tri-layer weave insulates in cold weather and wicks moisture in warm humid weather, providing true 4 season comfort.



Breathable polyester material insulates during cold weather to help you stay warm, and it absorbs moisture on warm nights to help you stay cool.



20in

Bed
Height

INFLATING TIMES*

AC Electric Pump

Queen 4½ minutes

NEW

*Inflating time varies by mattress size and desired firmness.

Item	Size	Approximate Inflated Size	Built-in Pump	Case Pack	Case Weight
64935EP	Queen	60" x 80" x 20"	110-120V	1 ea	26.2 lb (11.9 kg)
64936		1.52m x 2.03m x 51cm	220-240V		26.2 lb (11.9 kg)

MULTI-USE

A person is lying on a blue and white lounge chair on a grassy lawn. In the background, there is a calm pond reflecting the surrounding green trees and a grassy hill. The scene is peaceful and scenic.

Relax. Disconnect. Enjoy.

Intex knows that disconnecting from the pace of modern life doesn't mean giving up comfort. Intex Camping Airbeds have all been specifically designed to provide an uncompromising level of style, durability, comfort, and ease. Our camping airbeds come in a variety of shapes, sizes, and styles to suit nearly any outdoor adventure.

Enjoy the Great Outdoors



PRESTIGE DOWNY AIRBED

The perfect choice for the rugged outdoors. The flocked top provides a comfortable sleeping surface, and is easy to clean. The powerful battery-operated (6 x C-cell) pump goes anywhere!



WITH HANDHELD 6 C-CELL BATTERY PUMP		Approximate Inflated Size	Case Pack	Case Weight
66967 / E	Twin	39" x 75" x 8 3/4" 99cm x 1.91m x 22cm	4 ea	30.4 lb (13.8 kg)
66968 / E	Full	54" x 75" x 8 3/4" 1.37m x 1.91m x 22cm	3 ea	29.0 lb (13.2 kg)
66969 / E	Queen	60" x 80" x 8 3/4" 1.52m x 2.03m x 22cm	3 ea	33.4 lb (15.2 kg)

WITH HAND-HELD BATTERY PUMP

- 3-in-1 valve has extra-wide openings for fast inflating and deflating
- Conventional mattress sizes (L x W) for more sleeping area and a better fit for sheets
- Battery pump can also be used on other inflatables
- 8 3/4" (22cm) mattress thickness for extra soft comfort



Wave Beam Construction



For home or camping
Operates on 6 C-cell
batteries (not included)



The perfect
camping companion

INFLATING TIMES*	
TWIN	2 Minutes
FULL	2 Minutes
QUEEN	2 1/2 Minutes

*INFLATING TIME VARIES BY MATTRESS SIZE AND DESIRED FIRMNESS

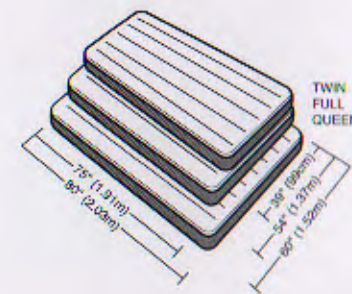

DOWNY AIRBED

This airbed has a flocked top that provides a more comfortable sleeping surface. Its unique wave beam construction eliminates uncomfortable surface bumps and provides a flat, uniform sleeping surface. The Downy airbed can be inflated with either the built-in manual foot pump or a regular pump.

WITH BUILT IN FOOT PUMP		Approximate Inflated Size	Case Pack	Case Weight
66950 / E	Cot Size	30" x 75" x 8¾" 76cm x 1.91m x 22cm	6 ea	36.4 lb (16.6 kg)
66927 / E	Twin	39" x 75" x 8¾" 99cm x 1.91m x 22cm	4 ea	29.8 lb (13.5 kg)
66928 / E	Full	54" x 75" x 8¾" 1.37m x 1.91m x 22cm	3 ea	28.3 lb (12.9 kg)
66929 / E	Queen	60" x 80" x 8¾" 1.52m x 2.03m x 22cm	3 ea	32.3 lb (14.7 kg)

BUILT-IN FOOT PUMP FOR CONVENIENCE

- Unique built-in bellow foot pump for convenience—no separate pump needed. Just step down to inflate and the pump springs back automatically for the next cycle
- New and improved foot pump construction allows for faster inflation
- 2-in-1 valve for inflating with optional electric or manual pumps
- Conventional mattress sizes (L x W) for more sleeping area and a better fit for sheets
- 8¾" (22cm) mattress thickness for extra soft comfort

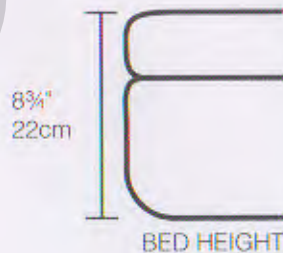
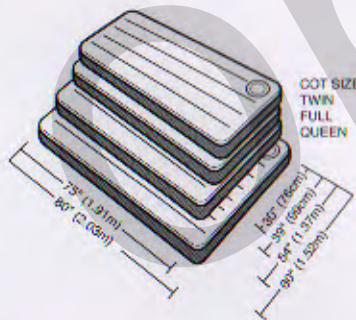

INFLATING TIMES*	
COT SIZE	
TWIN	2 Minutes
FULL	3 Minutes
QUEEN	4 Minutes

* INFLATING TIME VARIES BY MATTRESS SIZE AND DESIRED FIRMNESS



Wave Beam Construction



Built-in lightweight foot pump for easy inflation ~ No separate pump or power supply needed!

CLASSIC DOWNY AIRBED

You can't go wrong with this bed! Take it camping or use it for out of town guests. Our best selling Classic Downy Airbed is versatile and perfect for both in-home and camping. The wave beam construction creates a uniform sleeping surface that is guaranteed to give you a good night's rest wherever you are. Plush flocking provides a luxurious sleeping surface while keeping sheets in place. It's also easy to clean and waterproofed for camping use. The Classic Downy Airbed offers retailers and consumers the best value for their money at an opening price point.



AIRBED ONLY		Approximate Inflated Size	Case Pack	Case Weight
68950 / E	Cot Size	30" x 75" x 8 3/4" 76cm x 1.91m x 22cm	6 ea	31.2 lb (14.2 kg)
68757 / E	Twin	39" x 75" x 8 3/4" 99cm x 1.91m x 22cm	4 ea	26.2 lb (11.9 kg)
68758 / E	Full	54" x 75" x 8 3/4" 1.37m x 1.91m x 22cm	3 ea	25.9 lb (11.8 kg)
68759 / E	Queen	60" x 80" x 8 3/4" 1.52m x 2.03m x 22cm	3 ea	30.6 lb (13.9 kg)
68755 / E	King	72" x 80" x 8 3/4" 1.83m x 2.03m x 22cm	2 ea	23.9 lb (10.9 kg)

**AIRBED SET
INCLUDES TWO 1-BEAM PILLOWS
17" x 11" x 3 1/2" (43cm x 28cm x 9cm)
and a #68612 Double-Quick air pump**

		Approximate Inflated Size	Hand Pump	Case Pack	Case Weight
68765 / E	Queen	60" x 80" x 8 3/4" 1.52m x 2.03m x 22cm	68612	3 ea	34.4 lb (15.7 kg)



PLUSH FLOCKED TOP FOR COMFORT

- 2-in-1 valve has extra-wide openings for fast inflating and deflating
- Conventional mattress sizes (L x W) for more sleeping area and a better fit for sheets
- 8 3/4" (22cm) mattress thickness for extra soft comfort



*INFLATING TIME VARIES BY MATTRESS SIZE AND DESIRED FIRMNESS

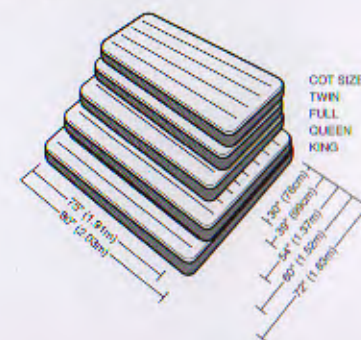
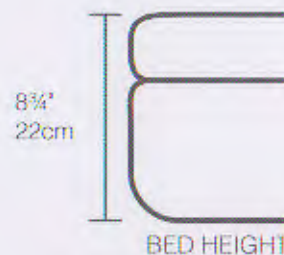

COT SIZE CAMPING MAT

Find your perfect sleep solution for the outdoors with the Cot Size Camping Mat. Made with rugged laminated PVC, this mat is designed to fit easily on cots or inside tents. This lightweight and portable mat provides a smooth and comfortable sleeping surface in any outdoor environment.

CAMPING MAT		Approximate Inflated Size	Case Pack	Case Weight
68708 / E	Cot Size	30" x 72" x 4" (76cm x 1.83m x 10cm)	6 ea	27.5 lb (12.5 kg)



SHELF BOX

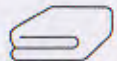

FOLDS COMPACTLY

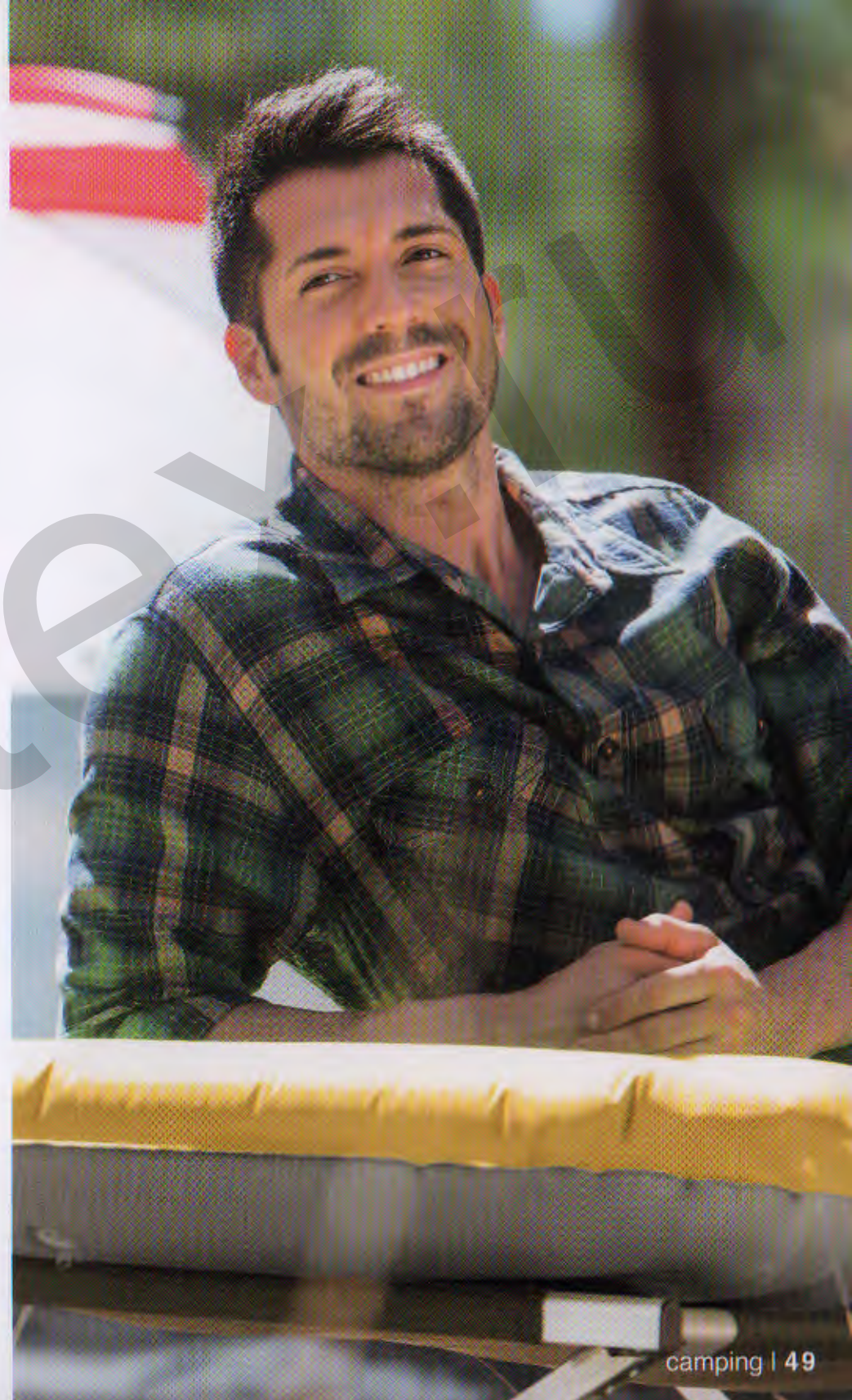
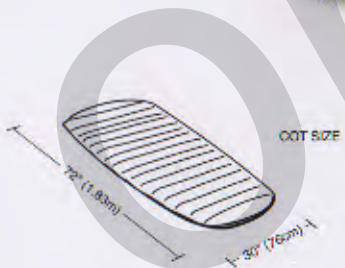

CAMPING MATS

A quick, simple and lightweight sleeping solution while camping. Wave beam construction provides a supportive sleeping surface ideal for the outdoors. Includes a soft top and laminate bottom for added comfort and durability for great sleep anywhere you go. Your next great outdoor adventure awaits...



#67997

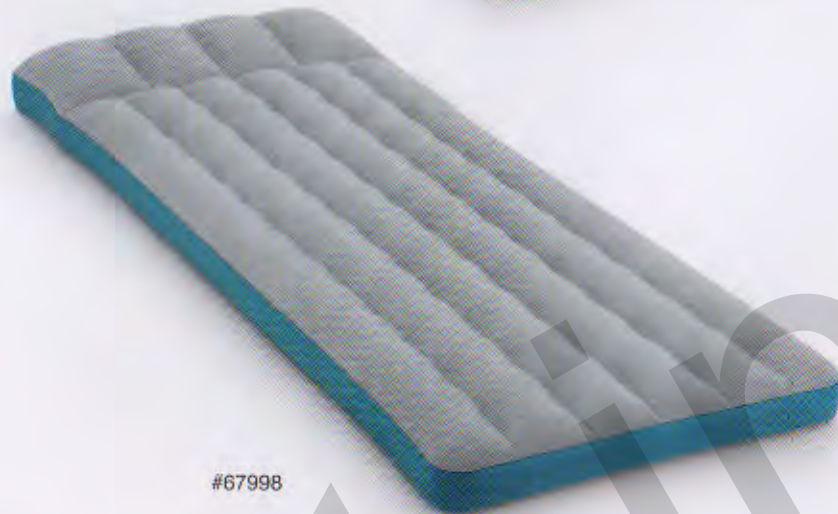

#67998

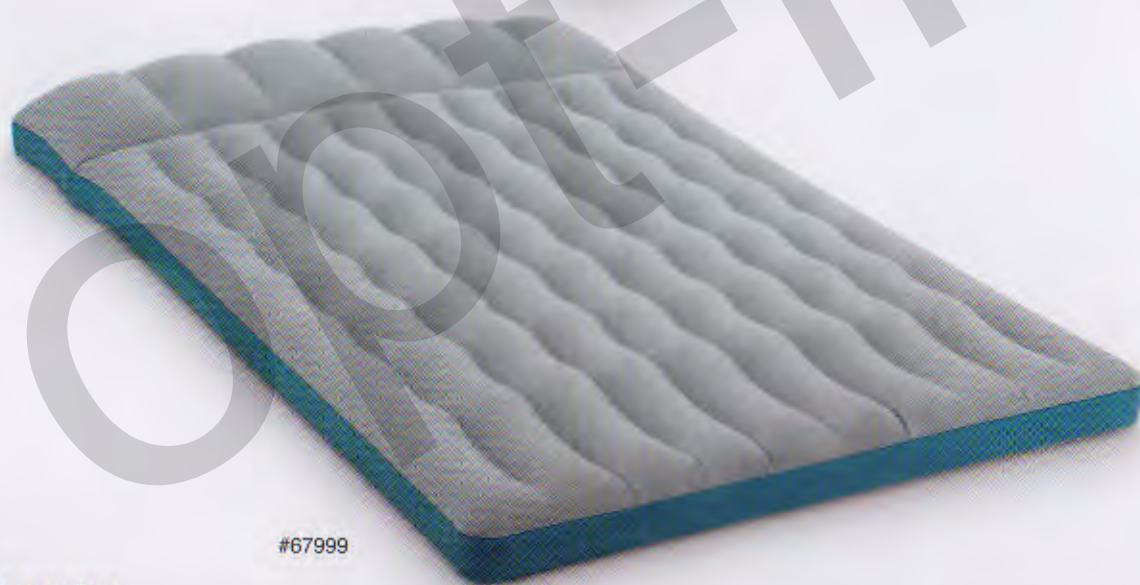

#67999

CAMPING MAT	Approximate Inflated Size	Case Pack	Case Weight
67997 / E	26½" x 72½" x 6¼" 67cm x 1.84m x 17cm	6 ea	23.1 lb (10.5 kg)
67998 / E	28½" x 74½" x 8" 72cm x 1.89m x 20cm	6 ea	29.4 lb (13.4 kg)
67999 / E	50" x 76" x 9½" 1.27m x 1.93m x 24cm	3 ea	25.1 lb (11.4 kg)

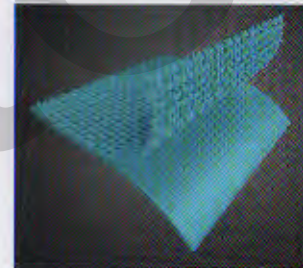

Puncture-resistant
2-ply laminate

PLUSH TOP WITH LAMINATED BOTTOM FOR COMFORT AND DURABILITY

- Velvety sleeping surface for extra comfort
- Each mat has a unique construction that helps provide more comfort to campers
- 2-ply laminate bottom provides extra durability for the outdoors



SHELF BOX

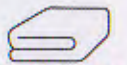

FOLDS COMPACTLY

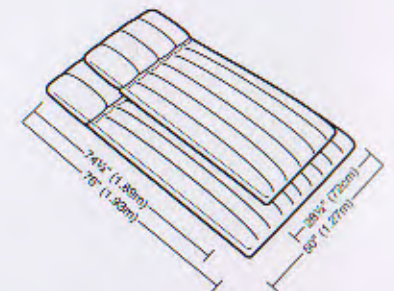
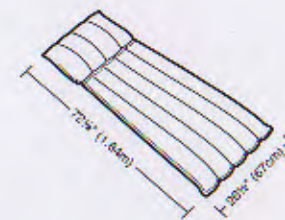

SUPER-TOUGH™ AIRBED

Bright, bold and compact, the Super-Tough™ airbed provides campers with the ultimate camping experience.

The Super-Tough™ PVC and polyester laminate create a smooth, yet strong sleeping surface, guaranteed to give campers a great night's sleep. High-strength Fiber-Tech™ fibers make up the inner construction and are combined with a puncture resistant laminated surface to make this camping airbed very strong, comfortable, and long-lasting.

For the ultimate in convenience, the Super-Tough™ bed is also available with a built-in 6 C-cell battery pump.

WITH BUILT-IN 6 C-CELL BATTERY PUMP

	Approximate Inflated Size	Case Pack	Case Weight
64791 / E Twin	39" x 75" x 8" 99cm x 1.91m x 20cm	3 ea	24.6 lb (11.2 kg)

STRENGTH, LIGHTWEIGHT, CONVENIENCE & COMFORT

- Fiber-Tech™ interior construction
- Bright and bold outdoor color
- Super-Tough™ laminated exterior surfaces



CARRY BAG



SHELF BOX

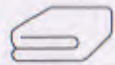

FOLDS COMPACTLY

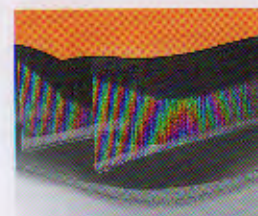
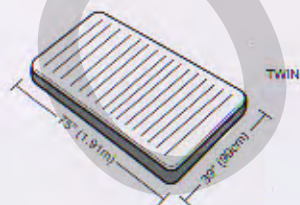

Fiber-Tech™ Technology



Perfect for camping
with 6 C-cell batteries
(not included)

AIR FURNITURE

Style. Color. Fun.
Cool Living Spaces with Intex

Intex brings to you an exciting and vibrant line of air furniture for any age, any setting and any season! With great colors and design, whether for the indoors or the outdoors, Intex has something for everyone. Decorate your room with Intex!



MODE CHAIR

Modern and effortlessly cool, our Mode Chair is a surefire way to turn your pad into the stylishly chic place it deserves to be. It's the best place to kick back or use as edgy party decor. The innovative design comes in two colors to fit your unique style including Lime Green and White. Not only will the colors support your style but the comfortable structure will support you, in style.

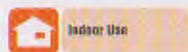

FOR EXTENDED SEATING

- Supportive back
- Textured seat for additional softness and contoured fit
- Matte finish
- Repair patch
- Shelf box

ITEM	Approximate Inflated Size	Color	Case Pack	Case Weight
6B592NP / EP	33" x 39" x 30" 84cm x 99cm x 76cm	2 Colors	6 ea. case	29.2 lb (13.3 kg)





BEANLESS BAG™ CHAIR ASSORTMENT

A great bean bag without the hassle of bean bag inserts and slipcovers. Just unfold and inflate, and in minutes you have a super soft bean bag that is perfect for lounging, studying, or watching movies. Vivid colors will brighten up any room. Comes in an assortment of two bright and vivid colors: Magenta Pink or Lime Green.

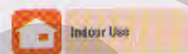

PERFECTLY PORTABLE BEANLESS BAG™

- Available in magenta pink and lime green
- Folds compactly for storage
- Shell box

ITEM	Approximate Inflated Size	Case Pack	Case Weight
68569NP / EP	42" x 41" x 27" 1.07m x 1.04m x 69cm	6 ea, asst	33.6 lb (15.3 kg)



U.S. Patent No. 6,152,530

BEANLESS BAG™ CLUB CHAIR

Relax in style and comfort with our Beanless Bag™ Club Chair. The luscious flocking in soothing olive green color offers a sophisticated appeal - making it a perfect addition to any room!

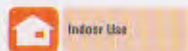

PERFECTLY PORTABLE BEANLESS BAG™

- Combo valve has extra-wide openings for fast inflating and deflating
- Folds compactly for storage
- Shell box

ITEM	Approximate Inflated Size	Case Pk.	Case Weight
68576NP / EP	49" x 47" x 30" 1.24m x 1.19m x 76cm	3 ea	25.0 lb (11.4 kg)

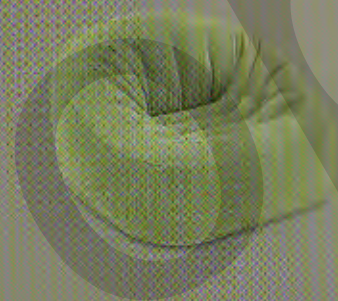



LUMI CHAIR ASSORTMENT

Unwind in style with our new Lumi Chair! Modern design with velvety plush surface, this chair adds a splash of color and flair to any room.



STYLISH COMFORT FOR ANY ROOM

- Combo valve has extra-wide openings for fast inflating and deflating.
- Folds compactly for storage.
- Available in olive green and sunny orange.
- Shelf box.

ITEM	Approximate Inflated Size	Case Pack	Case Weight
88677NP / EP	44" x 41" x 31" 1.12m x 1.04m x 79cm	4 ea. asst.	28.7 lb (13.5 kg)

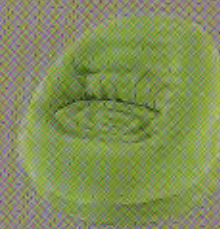

ULTRA LOUNGE

Attractive contours from any angle, the beauty of this lounge chair is matched only by its comfort. Contact surfaces on the top and sides are lined with flocking for the touch of luxury. The side cup holder is just as indispensable here as in your favorite sports car. The inflatable ottoman provides a great place to rest your feet.

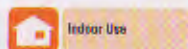

RELAX AT HOME WITH OUR ULTRA LOUNGE

- 2-in-1 valve has extra-wide openings for fast inflating and deflating
- Convenient cup holder for refreshments
- Folds compactly for storage
- Shelf box

ITEM		Approximate Inflated Size	Case Pack	Case Weight
88564NP / EP	Chair	38" x 51" x 30" 99cm x 130cm x 76cm	4 ea	31.5 lb (14.3 kg)
	Ottoman	25" x 11" 64cm x 28cm		



Comfortable seating with side cup holder





BEANLESS BAG™ CHAIR

Intex completes the Beanless Bag™ Chair line with the introduction of a warm, neutral color combined with our revolutionary corduroy texture flocking! Its elegant and luxurious look and feel will add a new dimension to any room!



PERFECTLY PORTABLE BEANLESS BAG™

- Folds compactly for storage
- Shelf box

ITEM	Approximate Inflated Size	Case Pack	Case Weight
68579NP / EP	42" x 41" x 27" 1.07m x 1.04m x 69cm	6 ea	34.3 lb (15.6 kg)

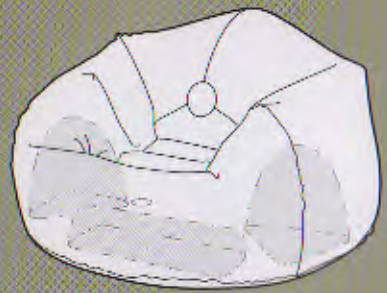

Beanless Bag™ chair inner structure
U.S. Patent No. 6,152,530

PULL-OUT CHAIR

Built for versatility, the Intex Pull-Out Chair is designed for relaxing just about anywhere, whether you are camping or at home. Watch TV, read a book, or just relax in the soft flocked chair and then pull out the cushion into a twin size air mattress when you are ready to go to sleep. Inflates and is ready to go in minutes!



STURDY COMFORT

- 2-in-1 valve has extra-wide openings for fast inflating and deflating
- Folds compactly for storage
- Cup holder for refreshments
- Shelf box



ITEM	Approximate Inflated Size	Case Pack	Case Weight
68565NP / EP	42" x 87" x 26" 1.07m x 2.21m x 66cm	2 ea	22.8 lb (10.1 kg)

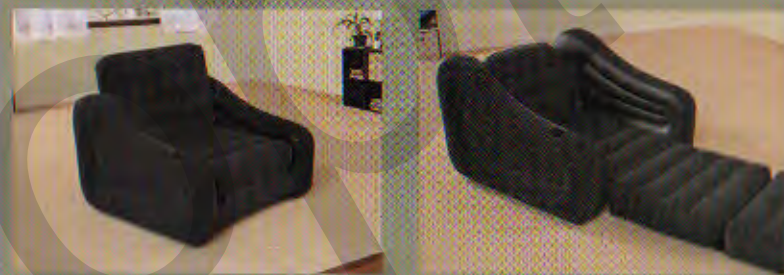



PULL-OUT SOFA

A versatile sofa that offers an affordable and comfortable sleeping solution for any home. Quick and easy to inflate, this sofa conveniently pulls out into a Queen-size bed that sleeps two people. Its portability makes it ideal to take on the road. The soft flocked surface provides added comfort, perfect for sitting or sleeping.

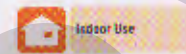

PRACTICAL & VERSATILE

- 2-in-1 valve has extra-wide openings for fast inflating and deflating
- 3 quick inflation and deflation valves
- Comfortable backrest and armrest
- Folds compactly for storage
- Two cup holders
- Shelf box



ITEM	Approximate Inflated Size	Case Pack	Case Weight
68566NF / EP	76" x 87" x 26" 1.93m x 2.21m x 66cm	2 ea	41.1 lb (18.7 kg)



MEGA LOUNGE

What makes this a mega lounge? Keeping multi-function in mind while covered in plush flocking, this lounge is designed for the ultimate comfort experience. Its long seat will let you sprawl out when you are gaming or watching TV. The included cup holder lets you keep snacks or a drink at arm's length.



Outdoor & Indoor Use

PERFECT FOR RELAXING AT HOME

- Velvet flocked finish
- Grooved and contoured shape for a natural fit and added comfort
- Long seat perfect for extending legs
- 1 cup holder
- 2-in-1 valve with extra wide openings for fast inflation and deflation
- Puncture-resistant 2-ply reinforced laminated bottom
- Additional chamber fills with water to anchor lounge
- Repair patch
- Shelf box

ITEM	Approximate Inflated Size	Case Pick	Case Weight
68595NP / EP	34" x 67" x 37" 86cm x 1.70m x 94cm	3 ea	26.6 lb (12.1 kg)





EMPIRE CHAIR

Modern, sophisticated and endlessly comfortable best describes this new addition to our line of inflatable chairs. In sunny orange, pink or lime green with an innovative transparent trim, this chair is the perfect combination of form and function. It's ideal for teens, college students and young professionals!



AN INVITING SPLASH OF COLOR AND COMFORT

- Great for both indoors and outdoors
- Puncture-resistant 2-ply reinforced laminated bottom
- Additional chamber fills with water to anchor chair
- Shelf box

ITEM	Approximate Inflated Size	Color	Case Pack	Case Weight
68581NP / EP	44" x 43" x 27" 1.12m x 1.09m x 69cm	Green	3 ea.	21.7 lb (9.9 kg)
68582NP / EP	44" x 43" x 27" 1.12m x 1.09m x 69cm	3 Colors	3 ea. assl	21.7 lb (9.9 kg)



ULTRA DAYBED LOUNGE

The Ultra Daybed Lounge invites you to relax, soak up the sun and hang out with friends. It's an elegant addition to any room, patio or yard as the reinforced bottom and soft flocking make it versatile enough for both indoors and outdoors.



Outdoor & Indoor Use

RELAX AT HOME WITH OUR ULTRA DAYBED LOUNGE

- Backrest for extra comfort
- Great for both indoors and outdoors
- Puncture-resistant 2-ply reinforced laminated bottom
- Additional chamber fills with water to anchor lounge
- Shelf box

ITEM	Approximate Inflated Size	Case Pack	Case Weight
68881NP / EP	75" (D) x 20" (H) 1.91m x 51cm	2 ea	29.5 lb (13.4 kg)





CORNER SOFA

A corner sofa can be a fantastic addition to any living room. This beautifully designed piece is luxurious yet convenient. Create an intimate conversation area or an expansive seating arrangement for family and friends. Casual and comfortable, this sofa is designed with deep seats and wide armrests, and sleekly streamlined for sophisticated appeal.

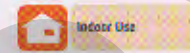

SPACIOUS COMFORT AND CONVENIENCE

- Quality-tested, waterproof-flocked surface for a luxurious feel
- 2-in-1 valve with extra-wide openings for fast inflating and deflating
- Neutral color to suit any home decor
- Repair patch
- Shell box



ITEM	Approximate Inflated Size	Case Pack	Case Weight
68575NP / EP	101" x 80" x 30" 2.57m x 2.03m x 76cm	1 ea.	28.6 lb (13.0 kg)



COZY KIDZ™ AIRBED

The perfect airbed for kids with soft, plush sleeping surface in two fun and exciting colors! It will come in handy for sleepovers, nap time and travel, without sacrificing comfort and convenience!

NEW

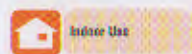

COZY & FUN

- Assorted bright, fun colors
- Soft flocking for extra comfort
- Includes carry bag
- Repair patch
- Shelf box

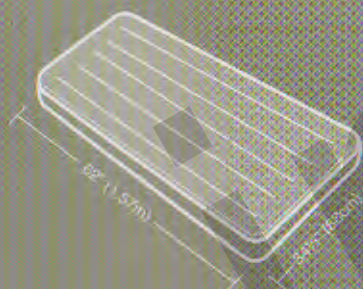

ITEM	Approximate Inflated Size	Case Pack	Case Weight
66803NP / EP	34 1/2" x 62" x 7" 88cm x 1.57m x 18cm	6 ea. asst	28.1 lb (11.9 kg)





KIDZ TRAVEL BED SET

Excellent solution to sleep comfortably when away from home.
Perfect for trips, sleepovers, camping and even for nap times!



QUICK & EASY SOLUTION

- Includes hand pump
- Inner mattress size: 28" x 52" x 4" (71cm x 1.32m x 10cm)
- Uses standard crib sheets
- Inflates and deflates quickly
- Includes carry bag
- Shelf box



Sleep area is
28" x 52" (71cm x 1.32m)
with soft frame surround

ITEM	Approximate Inflated Size	Hand Pump	Case Pack	Case Weight
66910NP / EP	42" x 66" x 10" 1.07m x 1.68m x 25cm	66612	3 ea	29.3 lb (13.3 kg)



ACCESSORIES

PILLOWS / AIRBED COVER

#68672 / E Downy Pillow

- 17" x 11" x 3½" (43cm x 28cm x 9cm)
- I-beam construction
- Pegable box

24 ea, 8.6 lb (3.9 kg)



#68675 / E Travel Pillow

- 14" x 12" x 4" (36cm x 30cm x 10cm)
- Black super soft flocked surface
- Perfect for those long plane and car trips
- Contoured for neck support
- Folds up for easy travel
- Pegable box

36 ea, 8.3 lb (3.8 kg)



#68676NP / EP Kidz Pillows

- 17" x 11" x 3½" (43cm x 28cm x 9cm)
- Available in Sunny Orange and Sky Blue
- Pegable box

24 ea, asst, 8.6 lb (3.9 kg)

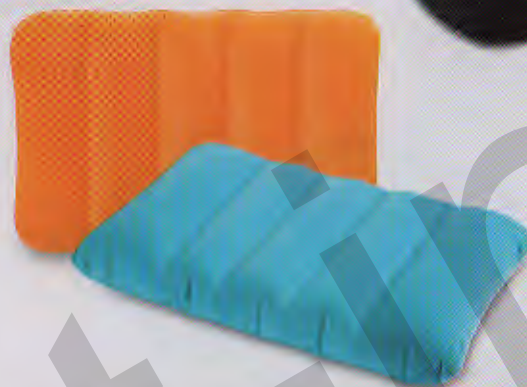

#69641

#69641 / E AIRBED COVER

- Fits twin size airbed up to 18" (46cm) high
- Elegant quilted pattern
- 100% Polyester
- 200 thread count
- 75D x 75D x 200T
- 39" W x 75" L x 4" H (99cm x 1.91m x 10cm)

3 ea, 4.8 lb (2.2 kg)

#69643 / E AIRBED COVER

- Fits queen size airbed up to 22" (56cm) high
- Elegant quilted pattern
- 100% Polyester
- 200 thread count
- 75D x 75D x 200T
- 60" W x 80" L x 4" H (1.52m x 2.03m x 10cm)

3 ea, 6.7 lb (3.1 kg)



#69643



Add a layer of comfort to your airbed with our Intex fitted polyester bed covers. The all-new fitted bed covers add a touch of home for your guests or your next outdoor adventure. Bed covers come in both Twin and Queen sizes. Ideal for mid-rise to double high beds.

ACCESSORIES

BACKYARD LED LIGHTING

68697/E LED OTTOMAN

- 34" x 13" (86cm x 33cm) inflated
- Great for indoor or outdoor use
- IPX8 waterproof
- 5-hour auto shut-off
- Rechargeable 2500mAh battery
- 12 white LED lights, 2.4W
- 1 RGB LED light, 3W
- USB cord for charging (wall charger not included)
- Repair patch
- Shelf box
- 3 ea, 10.5 lb (4.8 kg)



#68697

NEW

More than just patio furniture, this outdoor LED Ottoman provides fun lighting for any backyard! Take a seat and enjoy the elegant atmosphere you will create! This inflatable ottoman comes with a rechargeable battery that lasts up to 5 hours and you can choose between warm white or a smooth changing multi-colored setting to suit your mood!

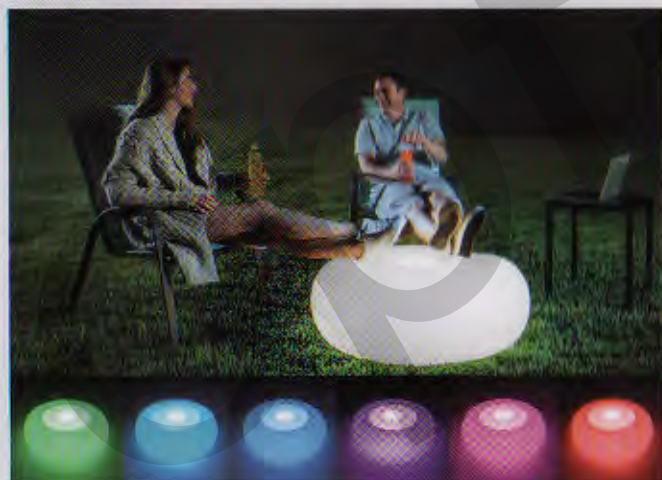

68693 / E LED FLOATING CRESCENT

- 53" x 17" x 35" (1.35m x 43cm x 89cm) inflated
- Great for indoor or outdoor use
- IPX8 waterproof
- 5-hour auto shut-off
- Rechargeable 2500mAh battery
- 12 white LED lights, 2.4W
- 1 RGB LED light, 3W
- USB cord for charging (wall charger not included)
- Repair patch
- Shelf box
- 3 ea, 8.7 lb (4.0 kg)



#68693

NEW

Decorative, these new LED accent lights are the perfect addition to any backyard. These stylish, inflatable lights are easy to use. Each light comes with a hook for hanging and a rechargeable battery that lasts up to 5 hours. You can set it to either a warm white or to a smooth changing multi-color setting to suit your mood.



NEW

#68695

68695/E LED FLOATING GLOBE

- 35" x 31" (89cm x 79cm) inflated
- Great for indoor or outdoor use
- IPX8 waterproof
- 5-hour auto shut-off
- Rechargeable 2500mAh battery
- 12 white LED lights, 2.4W
- 1 RGB LED light, 3W
- USB cord for charging (wall charger not included)
- Repair patch
- Shelf box
- 3 ea, 12.1 lb (5.5 kg)



ACCESSORIES

MANUAL PUMPS

#69613 / E Double Quick Mini Hand Pump

- 11½" (29cm)
- TUV RL approved
- Inflates on fore and back strokes
- 24 ea, 7.5 lb (3.4 kg)



#69611 / E Bellows Foot Pump

- 11" (28cm)
- TUV RL approved
- Inflates and deflates
- Shrink-wrapped with litho label
- 6 ea, 8.4 lb (3.8 kg)



#68610 / E Giant Bellows Foot Pump

- 50% more air flow than of #69611
- 12" (30cm)
- TUV RL approved
- Inflates and deflates
- Shelf box
- 6 ea, 13.6 lb (6.2 kg)



#68612 / E Double Quick I Hand Pump

- 11½" (29cm)
- 3 interconnecting nozzles with hose
- TUV RL approved
- Inflates on both up and down strokes
- Shelf box
- 12 ea, 11.1 lb (5.0 kg)



#68614 / E Double Quick II Hand Pump

- 2 times the air flow of #68612
- 14" (36cm)
- 3 interconnecting nozzles with hose
- TUV RL approved
- Inflates on both up and down strokes
- Shelf box
- 4 ea, 6.1 lb (2.8 kg)



#68605 / E Double Quick III S Hand Pump

- 3 times the air flow of #68612
- 14½" (37cm)
- 3 interconnecting nozzles with hoses
- TUV RL approved
- Inflates and deflates
- Inflates on both up and down strokes
- Shelf box
- 3 ea, 6.5 lb (3.0 kg)



#68615 / E Double Quick III Hand Pump

- 3½ times the air flow of #68612
- 19" (48cm)
- TUV RL approved
- Large nozzle threaded for athletic ball inflating needle (one included)
- Inflates athletic balls up to 8 psi
- Inflates and deflates
- Pumps on both up and down strokes
- Accordion hose with 4 nozzles
- Shelf box
- 3 ea, 7.8 lb (3.5 kg)



NEW design



ACCESSORIES

ELECTRIC PUMPS

Quick-Fill™ AC/DC Electric Pump features include:

- 3 interconnecting nozzles
- 12V DC & AC power adapter for easy Outdoor and Indoor use
- ETL approved (110-120V)
- CE approved (220-240V)
- Shelf box

NEW

#66633 (110-120V)
#66634 (220-240V)

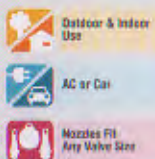

Quick-Fill™ DC Electric Pump features include:

- 3 interconnecting nozzles
- Plug into 12V DC automobile cigarette lighter or 12V DC accessory outlet
- ETL approved
- GS, CE approved
- Shelf box

NEW

#66636 (12V)



Quick-Fill™ AC Electric Pump features include:

- 3 interconnecting nozzles
- Thermo protector incorporated for safety
- TUV approved (110-120V)
- GS, CE approved (220-240V)
- Shelf box

NEW

#66639 (110-120V)
#66640 (220-240V)

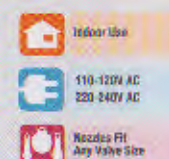

Quick-Fill™ Rechargeable Pump features include:

- 3 interconnecting nozzles
- A 12V DC power adapter for vehicle charging and a household AC power adapter for home charging
- 12V DC to inflate and deflate while recharging
- Automatic over-charge cut off for safety protection
- New shape with easy carry handle
- Built-in Battery charging indicator
- ETL approved (110-120V)
- CE approved (220-240V)
- Shelf box

NEW

#66641 (110-120V)
#66642 (220-240V)



Quick-Fill™ AC Electric Pump features include:

- 3 interconnecting nozzles with hose
- Thermo protector incorporated for safety
- New shape with easy carry handle
- TUV approved (110-120V model)
- GS, CE approved (220-240V model)
- Shelf box

NEW

#66643 (110-120V)
#66644 (220-240V)



These Quick-Fill™ electric pumps have a sleek, aerodynamic design that fits perfectly in the palm of your hand, yet still inflate even the largest of inflatables in a breeze.

Quick-Fill™ Battery Pump features include:

- Operates on 6 C-cell size batteries
- 3 interconnecting nozzles
- CE approved
- Shelf box



- Outdoor & Indoor Use
- 6 C Batteries Required (not included)
- Nozzles Fit Any Valve Size



#68608 (110-120V)
#68609 (220-240V)

Quick-Fill™ High PSI Indoor/outdoor Electric Pump features include:

- 3 interconnecting nozzles with hose
- For both indoor and outdoor use - plugs into cigarette lighter or household electrical outlet
- 2-speed switch
- Inflates athletic balls up to 12 psi
- Detachable DC cigarette cord
- ETL approved (110-120V)
- GS, CE approved (220-240V)
- Shelf box

- Outdoor & Indoor Use
- AC or Car
- Nozzles Fit Any Valve Size

Item #	Voltage			Disposable Batteries	Outdoor Use	Accordion Hose with 3 Nozzles	3 Interconnecting Nozzles	Max. Air Flow (L/min)	Case Pack	Weight lb (kg)
	110-120 AC	220-240 AC	12 DC							
66633E	•		•		•		•	≥480 (17.0CFM)	6 ea	13.4 (6.1)
66634		•	•		•		•	≥480 (17.0CFM)	6 ea	13.4 (6.1)
66636 / E			•		•		•	≥650 (23.0CFM)	6 ea	8.5 (3.9)
66639E	•		•		•		•	≥650 (23.0CFM)	6 ea	8.8 (4.0)
66640		•	•		•		•	≥650 (23.0CFM)	6 ea	8.4 (3.8)
66641E	• (CHARGING ONLY)		•		•		•	≥650 (23.0CFM)	4 ea	9.5 (4.3)
66642		• (CHARGING ONLY)	•		•		•	≥650 (23.0CFM)	4 ea	10.2 (4.6)
66643E	•		•		•	•	•	≥1100 (38.9CFM)	4 ea	11.3 (5.1)
66644		•	•		•	•	•	≥1100 (38.9CFM)	4 ea	11.0 (5.0)
66638 / E			•	6 x C	•		•	≥420 (14.8CFM)	6 ea	6.2 (2.8)
68608E	•		•		•	•	•	≥400 (14.1CFM)	4 ea	30.3 (13.8)
68609		•	•		•	•	•	≥400 (14.1CFM)	4 ea	30.3 (13.8)

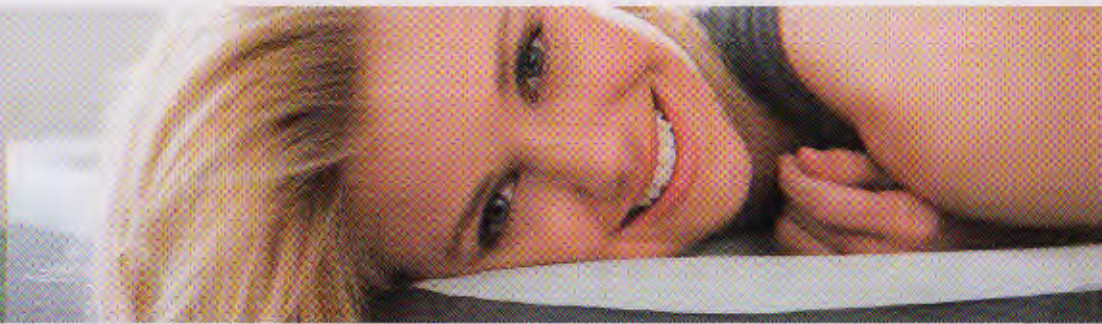

64115

DURA-BEAM® STANDARD

Approximate Inflated Size Built-in Pump



64115EP 64116	Twin	39" x 75" x 12" 99cm x 1.91m x 30cm	110 - 120V 220 - 240V
64117EP 64118	Queen	60" x 80" x 12" 1.52m x 2.03m x 30cm	110 - 120V 220 - 240V

P.14

64139

DURA-BEAM® STANDARD

Approximate Inflated Size Built-in Pump



64139EP 64140	Queen	60" x 80" x 20" 1.52m x 2.03m x 51cm	110 - 120V 220 - 240V
------------------	-------	---	--------------------------

P.17

64417

DURA-BEAM® PLUS

Approximate Inflated Size Built-in Pump



64417EP 64418	Queen	60" x 80" x 22" 1.52m x 2.03m x 56cm	110 - 120V 220 - 240V
------------------	-------	---	--------------------------

P.24-25

64455

DURA-BEAM® PLUS

Approximate Inflated Size Built-in Pump



64455EP 64456	Twin	39" x 75" x 18" 99cm x 1.91m x 46cm	110 - 120V 220 - 240V
64457EP 64458	Queen	60" x 80" x 18" 1.52m x 2.03m x 46cm	110 - 120V 220 - 240V

P.26-27

64121

DURA-BEAM® STANDARD

Approximate Inflated Size Built-in Pump



64121EP 64122	Twin	39" x 75" x 16½" 99cm x 1.91m x 42cm	110 - 120V 220 - 240V
64123EP 64124	Queen	60" x 80" x 16½" 1.52m x 2.03m x 42cm	110 - 120V 220 - 240V

P.15

64141

DURA-BEAM® STANDARD

Approximate Inflated Size Built-in Pump



64141 / E 64145EP 64146	Twin	39" x 75" x 10" 99cm x 1.91m x 25cm	- 110 - 120V 220 - 240V
64142 / E 64147EP 64148	Full	54" x 75" x 10" 1.37m x 1.91m x 25cm	110 - 120V 220 - 240V
64143 / E 64149EP 64150	Queen	60" x 80" x 10" 1.52m x 2.03m x 25cm	110 - 120V 220 - 240V
64144 / E	King	72" x 80" x 10" 1.83m x 2.03m x 25cm	-

P.13

64443

DURA-BEAM® DELUXE

Approximate Inflated Size Built-in Pump



64443EP 64444	Twin	39" x 75" x 20" 99cm x 1.91m x 51cm	110 - 120V 220 - 240V
64445EP 64446	Queen	60" x 80" x 20" 1.52m x 2.03m x 51cm	110 - 120V 220 - 240V

P.30-31

64461

DURA-BEAM® DELUXE

Approximate Inflated Size Built-in Pump



64461EP 64462	Twin	39" x 75" x 20" 99cm x 1.91m x 51cm	110 - 120V 220 - 240V
64463EP 64464	Queen	60" x 80" x 20" 1.52m x 2.03m x 51cm	110 - 120V 220 - 240V

P.32-33

64131

DURA-BEAM® STANDARD

Approximate Inflated Size Built-in Pump



64131EP 64132	Twin	39" x 75" x 16½" 99cm x 1.91m x 42cm	110 - 120V 220 - 240V
64135EP 64136	Queen	60" x 80" x 16½" 1.52m x 2.03m x 42cm	110 - 120V 220 - 240V

P.16

64411

DURA-BEAM® PLUS

Approximate Inflated Size Built-in Pump



64411EP 64412	Twin	39" x 75" x 18" 99cm x 1.91m x 46cm	110 - 120V 220 - 240V
64413EP 64414	Queen	60" x 80" x 18" 1.52m x 2.03m x 46cm	110 - 120V 220 - 240V

P.22-23

64447

DURA-BEAM® DELUXE

Approximate Inflated Size Built-in Pump



64447EP 64448	Queen	60" x 93" x 34" 1.52m x 2.36m x 86cm	110 - 120V 220 - 240V
------------------	-------	---	--------------------------

P.34-35

64707

DURA-BEAM® PLUS

Approximate Inflated Size



64707 / E	Twin	39" x 75" x 10" 99cm x 1.91m x 25cm
64708 / E	Full	54" x 75" x 10" 1.37m x 1.91m x 25cm
64709 / E	Queen	60" x 80" x 10" 1.52m x 2.03m x 25cm

P.20-21

64756 NEW

DURA-BEAM® STANDARD



			Approximate Inflated Size	Hand Pump
64756 / E	Cot Size	30" x 75" x 10"	76cm x 1.91m x 25cm	—
64757 / E	Twin	39" x 75" x 10"	99cm x 1.91m x 25cm	—
64758 / E	Full	54" x 75" x 10"	1.37m x 1.91m x 25cm	—
64759 / E	Queen	60" x 80" x 10"	1.52m x 2.03m x 25cm	88612
64755 / E	King	72" x 80" x 10"	1.83m x 2.03m x 25cm	—

P.12

64901

PREMAIRE®



		Approximate Inflated Size	Built-In Pump
64901EP 64902	Twin	39" x 75" x 18" 99cm x 1.91m x 46cm	110 - 120V 220 - 240V
64903EP 64904	Full	54" x 75" x 18" 1.37m x 1.91m x 46cm	110 - 120V 220 - 240V
64905EP 64906	Queen	60" x 80" x 18" 1.52m x 2.03m x 46cm	110 - 120V 220 - 240V

P.38

66803 NEW

	Approximate Inflated Size
66803NP / EP	34½" x 62" x 7" 88cm x 1.57m x 18cm

P.66

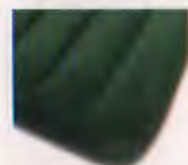
66967

		Approximate Inflated Size
66967 / E	Twin	39" x 75" x 8½" 99cm x 1.91m x 22cm
66968 / E	Full	54" x 75" x 8½" 1.37m x 1.91m x 22cm
66969 / E	Queen	60" x 80" x 8½" 1.52m x 2.03m x 22cm

P.46

68708

	Approximate Inflated Size
68708 / E	Cot Size 30" x 72" x 4" 76cm x 1.83m x 10cm

P.49

64769

PREMAIRE®



		Approximate Inflated Size	Built-in Pump
64769EP 64770	Queen	60" x 80" x 18" 1.52m x 2.03m x 46cm	110 - 120V 220 - 240V

P.40-41

64925

PREMAIRE®



		Approximate Inflated Size	Built-in Pump
64925EP 64926	Queen	60" x 80" x 18" 1.52m x 2.03m x 46cm	110 - 120V 220 - 240V

P.39

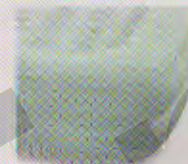
66810

		Approximate Inflated Size	Hand Pump
66810NP / EP		42" x 66" x 10" 1.07m x 1.68m x 25cm	68612

P.67

67765

DURA-BEAM® PLUS



		Approximate Inflated Size	Built-in Pump
67765EP 67766	Twin	39" x 75" x 13" 99cm x 1.91m x 33cm	110 - 120V 220 - 240V
67767EP 67768	Full	54" x 75" x 13" 1.37m x 1.91m x 33cm	110 - 120V 220 - 240V
67769EP 67770	Queen	60" x 80" x 13" 1.52m x 2.03m x 33cm	110 - 120V 220 - 240V

P.22-23

68950

		Approximate Inflated Size	Hand Pump
68950 / E	Cot Size	30" x 75" x 8½" 76cm x 1.91m x 22cm	—
68757 / E	Twin	39" x 75" x 8½" 99cm x 1.91m x 22cm	—
68758 / E	Full	54" x 75" x 8½" 1.37m x 1.91m x 22cm	—
68759 / E 68765 / E	Queen	60" x 80" x 8½" 1.52m x 2.03m x 22cm	— 68612
68755 / E	King	72" x 80" x 8½" 1.83m x 2.03m x 22cm	—

P.48

64791

		Approximate Inflated Size
64791 / E	Twin	39" x 75" x 8" 99cm x 1.91m x 20cm

P.51

64935 NEW

PREMAIRE®



		Approximate Inflated Size	Built-in Pump
64935EP 64936	Queen	60" x 80" x 20" 1.52m x 2.03m x 51cm	110 - 120V 220 - 240V

P.42-43

66950

		Approximate Inflated Size
66950 / E	Cot Size	30" x 75" x 8½" 76cm x 1.91m x 22cm
66927 / E	Twin	39" x 75" x 8½" 99cm x 1.91m x 22cm
66928 / E	Full	54" x 75" x 8½" 1.37m x 1.91m x 22cm
66929 / E	Queen	60" x 80" x 8½" 1.52m x 2.03m x 22cm

P.47

67997

		Approximate Inflated Size
67997 / E		26½" x 72½" x 6½" 67cm x 1.84m x 17cm
67998 / E		28½" x 74½" x 8" 72cm x 1.89m x 20cm
67999 / E		50" x 78" x 9½" 1.27m x 1.93m x 24cm

P.50

2019

COMFORT Collection

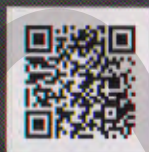

INTERNATIONAL

Intex Development Co., Ltd.
9th Floor, Everbright Centre,
106 Gloucester Road, Wanchai,
Hong Kong
Tel: (852) 2827-0000
Fax: (852) 2311-8200
E-mail: info@intexdevelopment.com
Web: www.intexdevelopment.com

USA

Intex Recreation Corp.
P.O. Box 1440
Long Beach, CA 90801-1440
USA
Tel: (310) 549-5400
Fax: (310) 513-8905
Web: www.intexcorp.com



EUROPE

Intex Trading B.V.
Venneveld 9,
4705 RR Roosendaal,
The Netherlands
Tel: (31) 165-593920
Fax: (31) 165-593969
E-mail: info@intexcorp.nl
Web: www.intexcorp.nl

Intex Trading s.r.o.
Benešovská 23
101 00 Praha 10
Czech Republic
Tel: (420) 267 312 645
Fax: (420) 267 312 552
E-mail: info@intexcorp.cz
Web: www.intexdevelopment.com

Unitex Service (France) S.A.S.
Z.A. de Milleure Bois du Ban - N°4
71480 LE MIROIR, France
Tel: (33) 385 75 84 84
Fax: (33) 385 75 84 65
E-mail: info@intexcorp.com.fr
Web: www.intex.fr

INTEX®

©2018 Intex Marketing Ltd. - Intex Development Co., Ltd. - Intex Recreation Corp. All rights reserved. • Printed in China
®™ Trademarks used in some countries of the world under license from Intex Marketing Ltd. to Intex Development Co., Ltd.,
G.P.O. Box 28029, Hong Kong, and Intex Recreation Corp., P.O. Box 1440, Long Beach, CA 90801.