

37 TON LOG SPLITTER

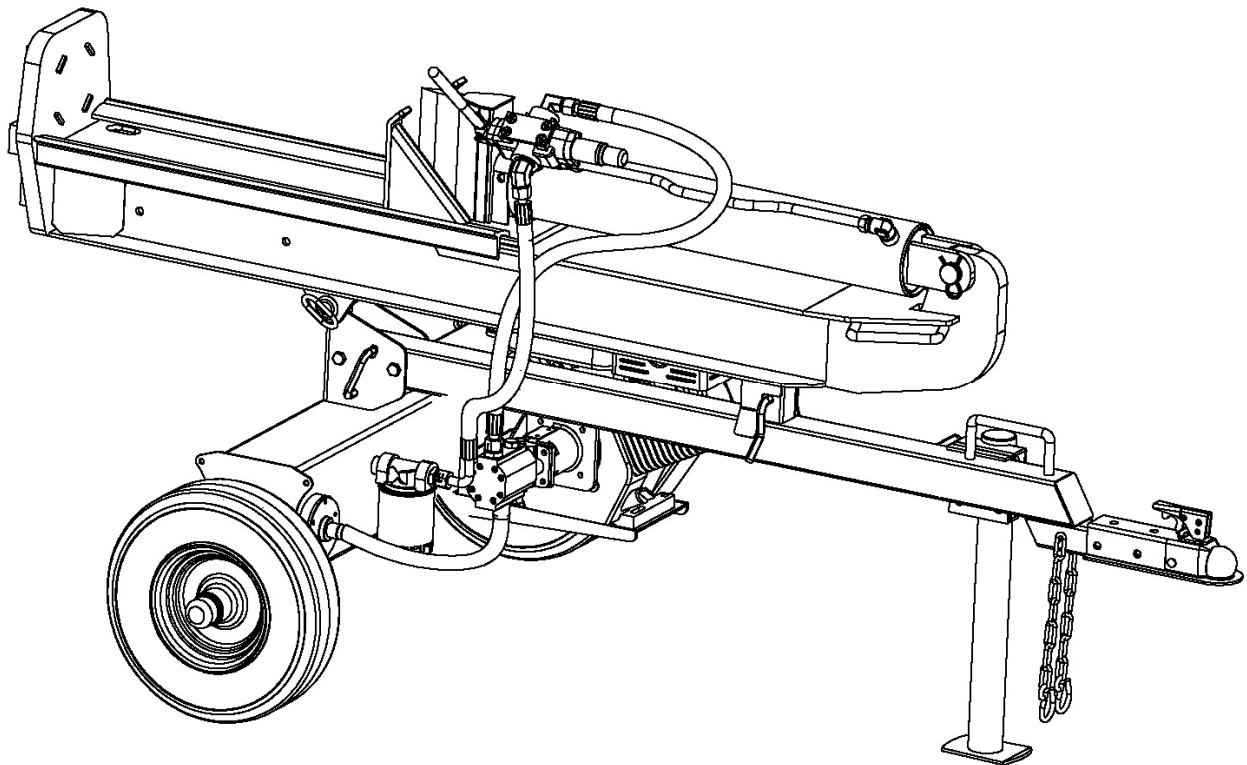

Instruction & Assembly

How to Assemble Video at www.ytlinternational.com

SAVE THESE INSTRUCTIONS FOR FUTURE REFERENCE

Table of Contents

General Warnings and Rules	3
Hazard Signal Word Definitions.....	4
Controls and Features Identification.....	5, 6
Assembly Instructions	7, 8, 9, 10
Operation Instructions	11 12, 13, 14
Maintenance and Storage	15
Troubleshooting	16
Specifications	17
Parts Drawing & Parts List	18, 19, 20
Limited Warranty	21

GENERAL WARNINGS

READ and UNDERSTAND this manual completely before using 37 Ton Log Splitter.

Operator must read and understand all safety and warning information, operating instructions, maintenance and storage instructions before operating this equipment. Failure to properly operate and maintain the log splitter could result in serious injury to the operator or bystanders.

Operation Warnings

- Do not at any time carry passengers, sit or stand on the log splitter.
- Do not allow children to play on, stand upon or climb on the log splitter.
- Always inspect the log splitter before using to assure it is in good working condition.
- Replace or repair damaged or worn parts immediately.
- Always check and tighten hardware and assembled parts before operation.
- Do not exceed equipment maximum load capacity of 37 tons.
- Avoid large holes and ditches when towing the equipment.
- Always operate the log splitter on clear and level ground.
- Do not operate the log splitter at night, only during daylight hours.
- Always tow at reduce speed in rough terrain, along creeks, ditches and on hillsides.
- To avoid personal injury and/or equipment damage **DO NOT EXCEED 45 MPH.**
- Always refer to the vehicle owner's manual for proper towing.
- Always secure and lock the log splitter to the vehicle hitch before towing.

Crush and Cut Hazards

- Always keep hands and feet clear from moving parts while operating the equipment.
- Always clear and keep work area clean and free of debris when operating.
- Always wear safety gear, eye protection, gloves and work boots when operating the log splitter.

WARNING

The warnings, cautions, and instructions outlined in this instruction manual cannot cover all possible conditions or situations that may occur. It must be understood by the operator that common sense and caution are factors which cannot be built into this product and must be supplied by the operator.





PROP 65 WARNING

This product can expose you to chemicals including lead and lead compounds which are known to the State of California to cause cancer and birth defects or other reproductive harm. For more information, go to www.P65Warnings.ca.gov.

Assembly Is Required

This product requires assembly before use. See "Assembly" section for instructions. Because of the weight and/or size of the log splitter, it is recommended that another adult be present to assist with the assembly. **INSPECT ALL COMPONENTS** closely upon receipt to make sure no components are missing or damaged.

Hazard Signal Word Definitions

	<p>This is the safety alert symbol. It is used to alert you to potential personal injury hazards. Obey all safety messages that follow this symbol to avoid possible injury or death.</p>
	<p>DANGER indicates an imminently hazardous situation which, if not avoided, will result in death or serious injury.</p>
	<p>WARNING indicates a potentially hazardous situation which, if not avoided, could result in death or serious injury.</p>
	<p>CAUTION indicates a potentially hazardous situation which, if not avoided, may result in minor or moderate injury.</p>
	<p>CAUTION used without the safety alert symbol indicates a potentially hazardous situation which, if not avoided, may result in property damage.</p>

ABOUT YOUR 37 TON LOG SPLITTER

This hydraulic log splitter has a heavy-duty steel construction and 37 tons of ram force. When there's work to be done, you need outdoor power equipment you can rely on, this log splitter will get the job done fast. It is designed to work in both the horizontal and vertical position. It is easy to tow, easy to use and maintain. Never exceed the rated capacity of 37 tons when operating the log splitter.

Technical specifications on the log splitter are provided in the "Specifications" section of this manual.

Controls and Features Identification

Read this owner's manual before operating the equipment. Familiarize yourself with the location and function of the controls and features. Save this manual for future reference.

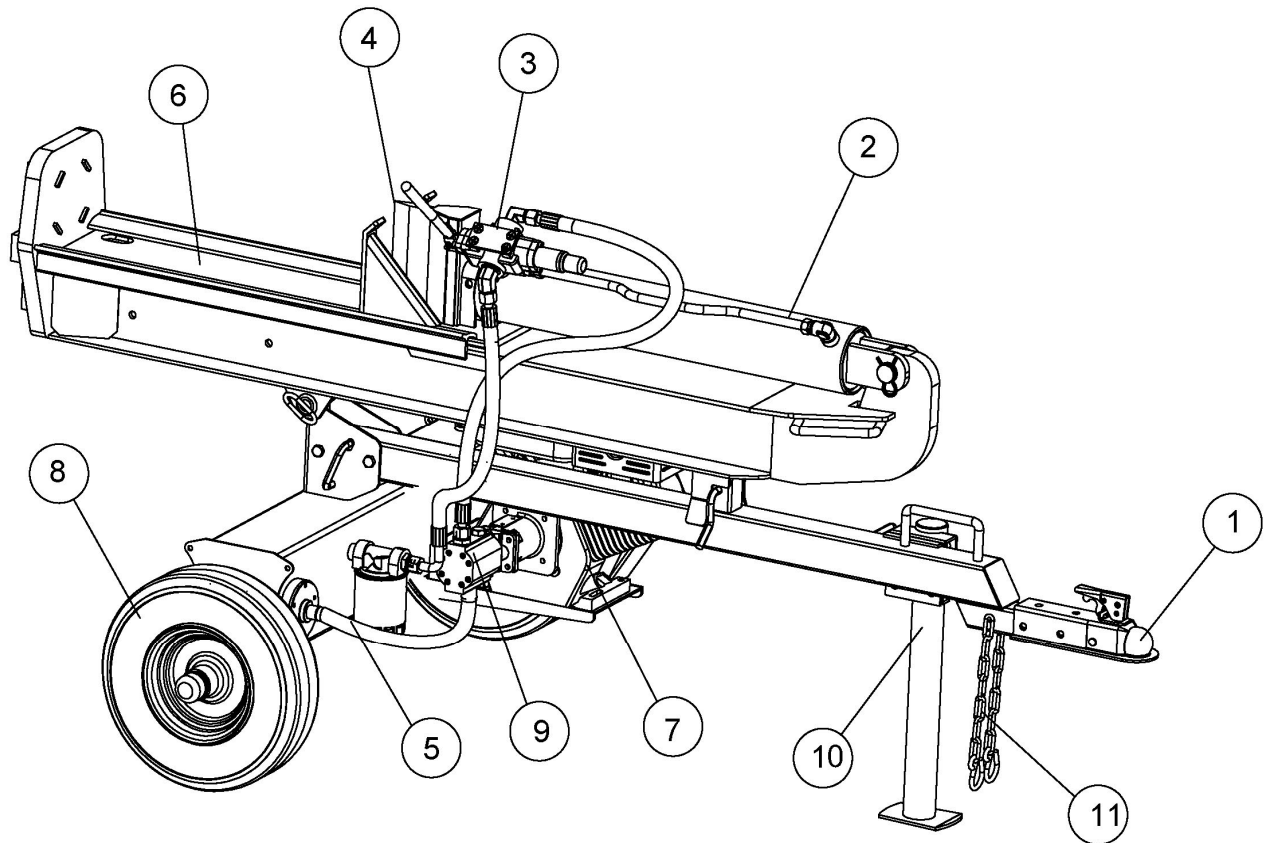

- 1) **2" Coupler** – Attaches the log splitter to the 2" ball.
- 2) **Hydraulic Cylinder** – 5" bore and 24-1/8" stroke, rated to 3625 psi.
- 3) **Control Valve** – Controls the forward and backward movement of splitting wedge.
- 4) **8" Wedge** - Features wedge wings and tapered ends making splitting easier.
- 5) **External Filter** – Filters the hydraulic oil.
- 6) **Beam** – 8.66" wide
- 7) **Engine** - Air cooled engine powers the hydraulic pump.
- 8) **Tires** - Maximum rated towing speed is 45 MPH.
- 9) **Gear Pump**- Pumps the hydraulic oil through the system.
- 10) **Support Leg**- Supports the log splitter while operating.
- 11) **Safety Chains** - Safety feature to prevent loss of log splitter while towing.



WARNING

Read and follow all instructions for assembly and operation. Failure to properly assemble this equipment could result in serious injury to the user or bystanders, or cause equipment damage.



Engine Shipped Without Oil.

Before starting engine, fill with SAE 10W-30 motor oil.
See engine manual for engine oil capacity.

Hydraulic Reservoir is Shipped Without Oil.

When adding oil verify the oil level reads 1 from the top of hydraulic reservoir if marking is not shown fill to the neck.

Inspect all Log Splitter Components.

If you have damaged components: Contact the freight company that delivered the log splitter and file a claim.

37 TON LOG SPLITTER ASSEMBLY

Set the shipping crate on a solid flat surface and carefully remove the lid. Use two people and take all parts out of the shipping crate and inspect the components to ensure there are no missing pieces before starting to assemble the log splitter follow steps 1 through 8.

TOOLS REQUIRED

- Rubber or Wooden Hammer
- 13mm, 16mm, 17mm, 18mm, 19mm, 24mm, 27mm Wrenches
- Large Adjustable Wrench
- Phillips Screwdriver
- Pliers

Assembly Instructions

STEP 1: Wheel Assembly

1. Attach the wheel (#33) to the oil tank axle (#42) using a flat washer $\text{Ø}20$ (#52) and tighten the wheel with the hex slotted nut M20x1.5 (#35). Lock the hex slotted nut M20x1.5 (#35) in place using the cotter pin $\text{Ø}4 \times 36$ (#71). Install the axle cap (#39) on the end using rubber hammer.

NOTE: Use a black plastic bushing to fix the axle cap (#39) like below picture. Please cover the black bushing onto the axle cap, and use rubber/wooden hammer knocking the end of the plastic bushing and make the axle cap fixed on wheel.

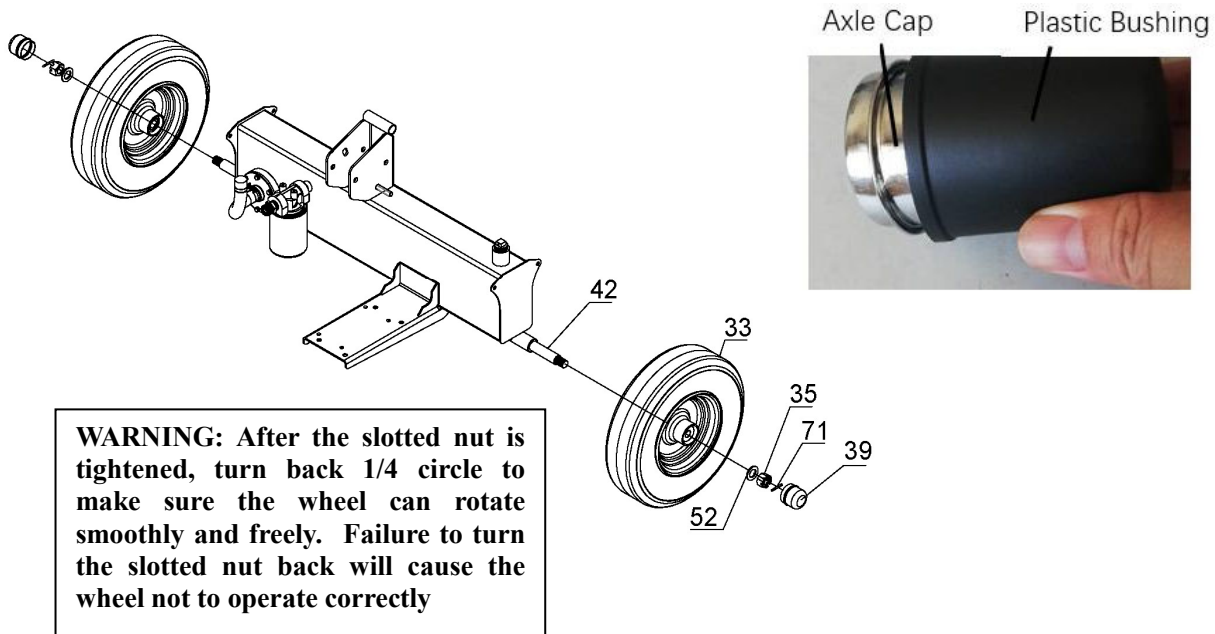

STEP 2: Attach Tow Bar to the Wheel Assembly

1. Attach the tow bar (#60) to the oil tank using hex bolt M12x100 (#23), flat washer $\text{Ø}12$ (#63) and nylon lock nut M12 (#12).

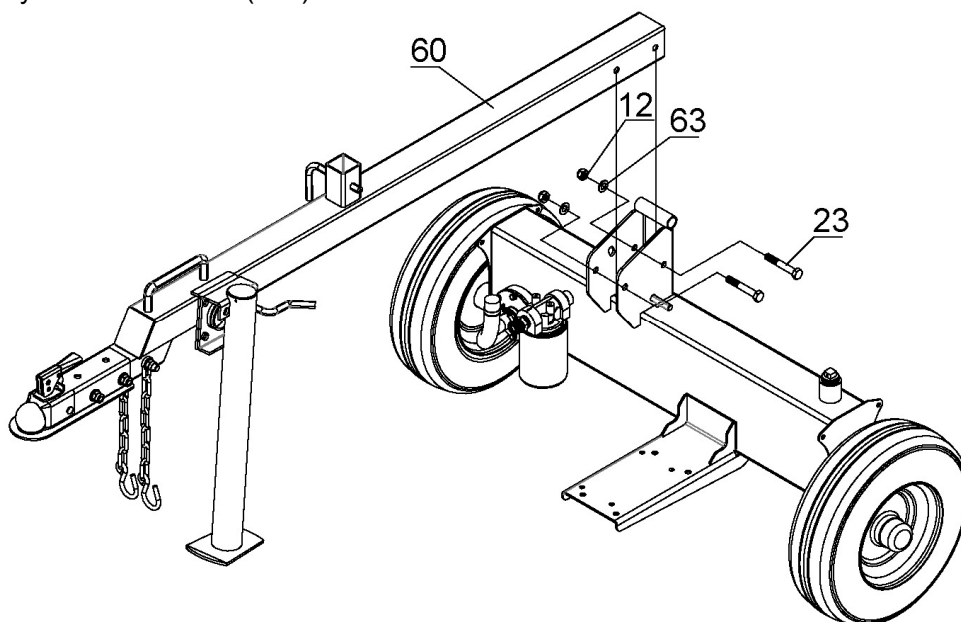

STEP 3: Attach the Beam Assembly

1. Connect the Beam (#16) and Oil Tank using Hitch Pin (#17), then lock the Hitch Pin (#17) using R Pin (#20).

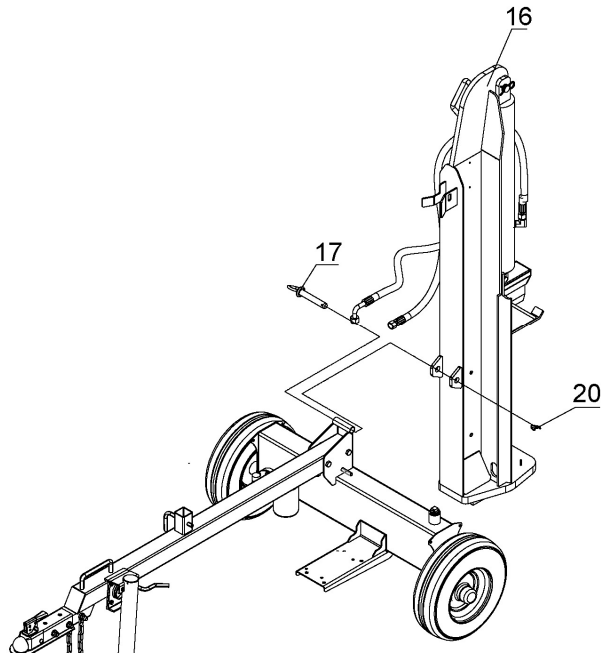

STEP 4: Attach Engine to Mounting Plate

1. Place the polyurethane block (#53) and large flat washer $\text{Ø}10$ (#56) between the mounting plate and engine.
2. Position the engine (#32) over the blocks and secure it to the mount plate put the hex bolt M10x70 (#44) through the bottom of the plate (bolt should go through blocks, flat washer and engine base). Place a flat washer $\text{Ø}10$ (#75), lock washer $\text{Ø}10$ (#74) and tighten the nylon lock nut M10 (#73)
3. Attach the clear oil pipe (#51) to the bottom of the gear pump and secure with clamp (#49).

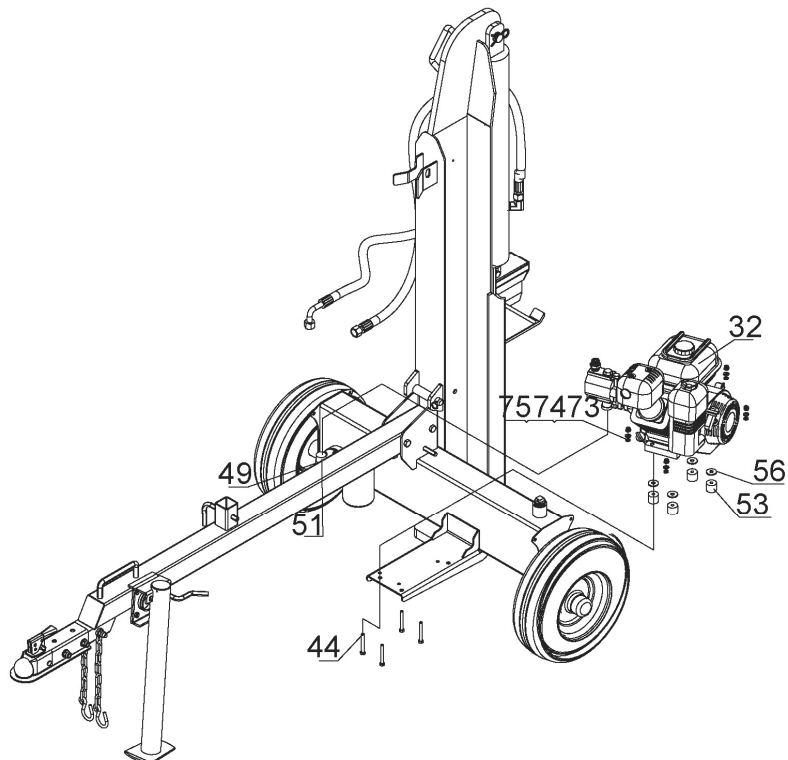

STEP 5: Attach Hydraulic Hose

1. Put O ring Ø14x2.5 (#18) on the gear pump connector (#22), and attach the hydraulic hose (valve-pump) (#15) to the gear pump connector (#22).
2. Put the O ring Ø17x2.5 (#69) on the connector (#48), and attach the hydraulic hose (valve-external filter) (#6) to the end of the connector (#48).

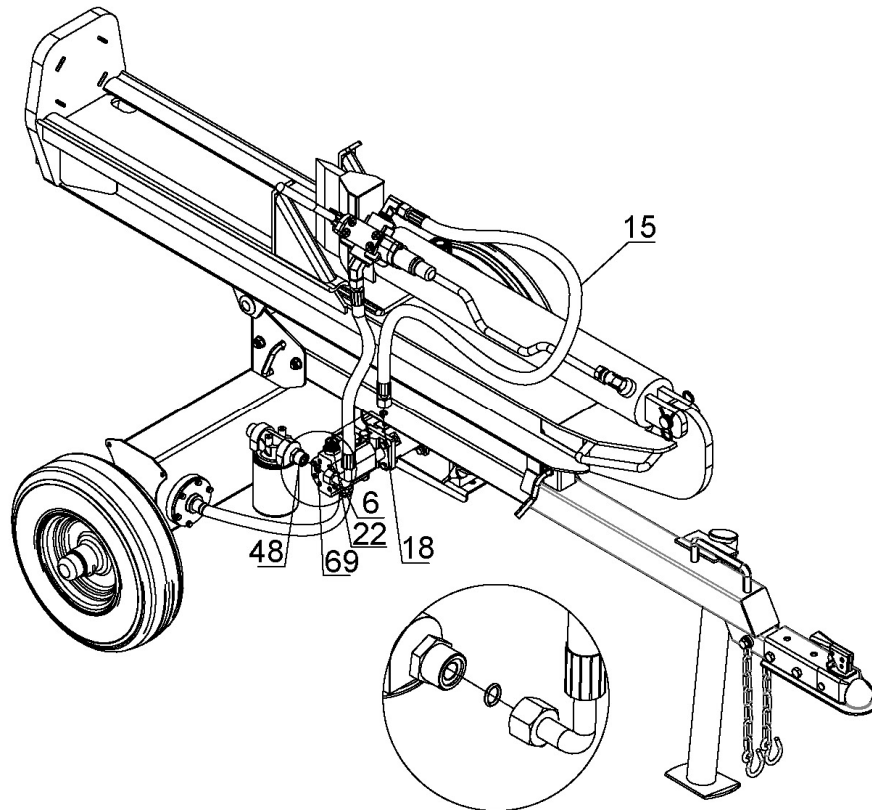

STEP 6: Add Engine Oil

1. Make sure the log splitter is on a level surface.
2. Remove oil fill cap/dipstick to add oil.
3. Refer to the separate owner's engine manual for the amount needed of SAE10W-30 engine oil; replace oil fill cap/dipstick.
4. Check engine oil level daily and add as needed.

NOTE: During the break-in period check the engine oil level often.

CAUTION

DO NOT attempt to crank or start the engine before it has been properly filled with the recommended type and amount of oil. Damage to the log splitter as a result of failure to follow these instructions will void your warranty.

STEP 7: Add Gasoline to the Engine

1. Use only clean, fresh, regular unleaded fuel with a minimum 85 octane rating.
2. DO NOT mix oil with fuel.
3. Remove the fuel cap and slowly add fuel to the tank. DO NOT overfill allow approximately ¼ inch of space for fuel expansion.
4. Screw on the fuel cap and wipe away any spilled fuel.



DANGER

Log splitter engine exhaust contains carbon monoxide, a colorless, odorless, poison gas. Breathing carbon monoxide will cause nausea, dizziness, fainting or death. If you start to feel dizzy or weak, get to fresh air immediately.

Operate log splitter outdoors only in a well ventilated area.

DO NOT operate the log splitter inside any building, enclosure or compartment.

DO NOT allow exhaust fumes to enter a confined area through windows, doors, vents or other openings.

DANGER CARBON MONOXIDE, using a log splitter indoors **CAN KILL YOU IN MINUTES**.



CAUTION

Fuel and fuel vapors are highly flammable and extremely explosive.

Fire or explosion can cause severe burns or death.

Unintentional startup can result in entanglement, traumatic amputation or laceration.

Only use regular unleaded gasoline with a minimum 85 octane rating.

DO NOT mix oil and gasoline together.

Fill tank approximately ¼" below the top of the tank to allow for fuel expansion.

DO NOT fill fuel tank indoors or when the engine is running or hot.

DO NOT light cigarettes or smoke when filling the fuel tank.

STEP 8: Add Hydraulic Oil

1. The log splitter needs to be on a flat, level surface before adding the hydraulic oil.
2. Remove the oil cap from the hydraulic oil tank.
3. Add 4.49 gallons of hydraulic oil AW32, AW46 & universal hydraulic oil are all acceptable types of fluid. **Automatic transmission fluid should be used when operating in temperatures below 32 degrees** (all units are tested and have excess oil in the ram).
4. Check the hydraulic oil level.
5. Start engine and use the control lever to extend and retract wedge several times to remove air from the lines.
6. With the wedge retracted, check hydraulic oil level again and fill if necessary.



WARNING

DO NOT remove the hydraulic oil fill cap when the engine is running or hot. Hot oil can escape causing severe burns. Always allow the log splitter to cool completely before removing the hydraulic oil cap.

High fluid pressure and temperatures are created in the hydraulic log splitters. Hydraulic fluid will escape through a pin-size hole opening and can puncture skin and cause severe blood poisoning.

Inspect hydraulic system regularly for possible leaks. **Never check for leaks with your hand while the system is pressurized. Seek medical attention immediately if injured by escaping fluid.**

Make sure all fittings are tight and secure before applying pressure. Relieve system pressure before servicing.

Make sure the hydraulic hoses do not touch any hot surfaces or cutting areas.

Hoses need to be positioned where they are clear from the engine and cutting wedge. To avoid serious bodily injury always inspect the hoses before operating the log splitter.

Operation Instructions

WARNING

Before operating or using the log splitter, review the instructions below and all safety information. Failure to follow these instructions may result in property damage or injury to the operator or bystanders.

WARNING

ALWAYS use the log splitter for its intended use.
ONLY use the log splitter to split wood logs, length wise with the grain.
NEVER modify, alter or change the log splitter in anyway, modifications will void the warranty.
NEVER attach a rope, cable or other device to the control lever on the log splitter.
ONLY operate the log splitter in daylight.
NEVER leave the log splitter unattended while the engine is running.
DO NOT change the splitting position with the engine running. Contact with the muffler can cause serious burns.
ALWAYS make sure the beam is in the locked position.
DO NOT let the beam drop as it could crush fingers or cause damage to the log splitter.
NEVER operate or let anyone else operate, the log splitter while under the influence of alcohol, drugs, or medication.

USING YOUR LOG SPLITTER

1. DO NOT at any time carry passengers, sit or stand on the log splitter.
2. Check the hydraulic oil level and visually inspect all hoses and attachments for problems.
3. Inspect the engine and make sure the engine oil level is correct.
4. Before towing the log splitter the tires need to be fully inflated.

TIRE WARNING

DO NOT over inflate tires. Serious injury can result if tires explode.
DO NOT tow the log splitter if the tires are worn or will not hold air.
DO NOT exceed the maximum 45 MPH towing speed.

5. Refer to the vehicle owner's manual for proper safety and towing instructions.

TOWING WARNING

Serious injury or death can occur if towing safety rules are not followed.
Always use safety chains, secure and lock the log splitter to the vehicle hitch before moving.
Drive safely. Be aware of the added length of the log splitter.
Never exceed the maximum travel speed of 45 mph.
Never ride or transport cargo on the log splitter.
Turn off the vehicle before leaving the log splitter unattended.
Block the log splitter wheels to prevent unintended movement.

6. The log splitter must have at least seven feet of clearance from combustible material. It needs to be on a dry and level surface with good footing. Do not work on mud, ice, brush or snow. When using the log splitter the work zone must be maintained at all times.

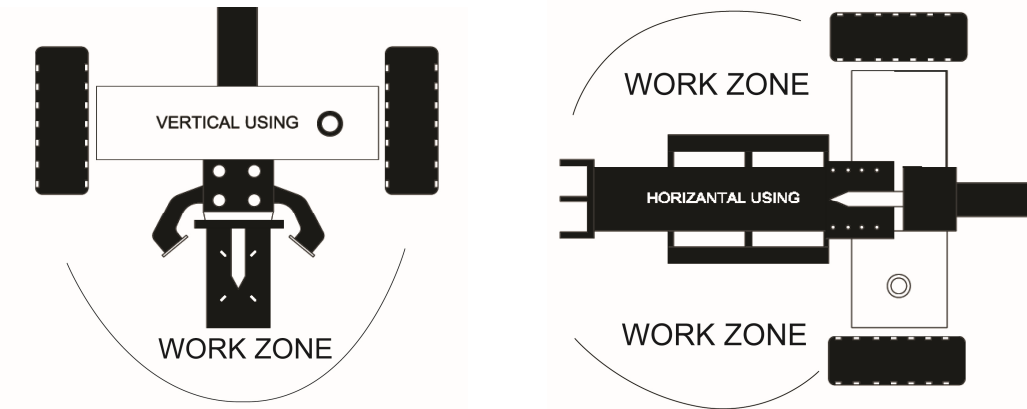

NOTE: Serious accidents can happen when other people are allowed inside the work zone. Keep everyone else outside the work zone while operating the control lever.

7. Always wear safety gear, eye protection, gloves and work boots when operating the log splitter.
8. Start the engine and make sure the log splitter is on level ground before operating.

NOTE: The hydraulic oil needs to be above 10°F (-12C°) before starting the engine. Cold hydraulic oil can damage the hydraulic pump. If outdoor air temperature is below 32°F (0C°) allow the log splitter to warm up by extending and returning the wedge several times before splitting wood.

9. Put the support leg in the down position to prevent the log splitter from moving during operation and block both tires.
10. Set the log splitter in either the horizontal or vertical position.

NOTE: HORIZONTAL position is used for lighter logs that can easily be loaded onto the beam. The VERTICAL position is used for either light logs or heavy logs that are difficult to load onto the beam. Back injury can result from lifting logs onto the log splitter if proper lifting techniques are not used.

11. Load a log onto the beam against the endplate (Max Log Length-26”).

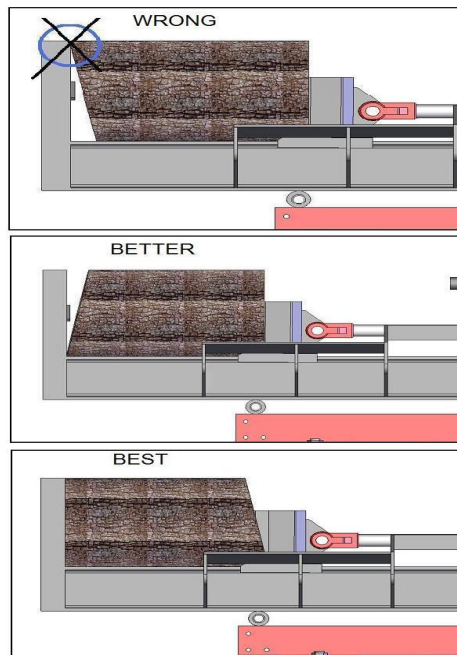

12. Make sure hands are clear from the wedge and crush hazard areas.

⚠ CRUSH WARNING

Wedge can cut through skin and break bones. Keep both hands away from wedge and beam slide. Serious accidents can happen when other people are allowed inside the work zone. Keep everyone else out of the work zone while operating control lever.
 DO NOT wear loose clothing. It can get tangled in moving parts of log splitter.
 Only use the log splitter in daylight so you can see what you are doing.

13. Push control lever FORWARD by one hand to split the log.

14. Push control lever BACKWARD by one hand to return wedge to its original position.

⚠ CAUTION

If a log gets stuck, embedded or will not split completely, push the control lever in the reverse direction and allow the splitter to strip the log from the wedge.
 If the log still remains stuck, embedded or will not split, turn the machine off and use a sledge hammer and crow bar to remove the log.
 ALWAYS keep hands clear of the log and wedge while it is retracting.

15. Always keep work zone clean and free of split wood and debris.

Operation Instructions

HORIZONTAL POSITION

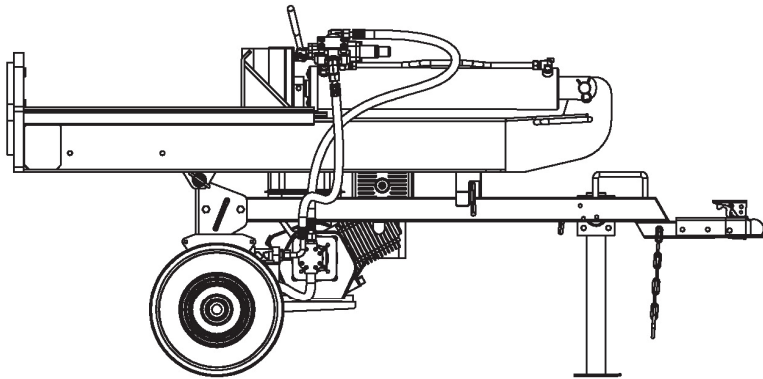

VERTICAL POSITION

1. Pull beam lock pin
2. Rotate the beam in the upright position by lifting the beam.

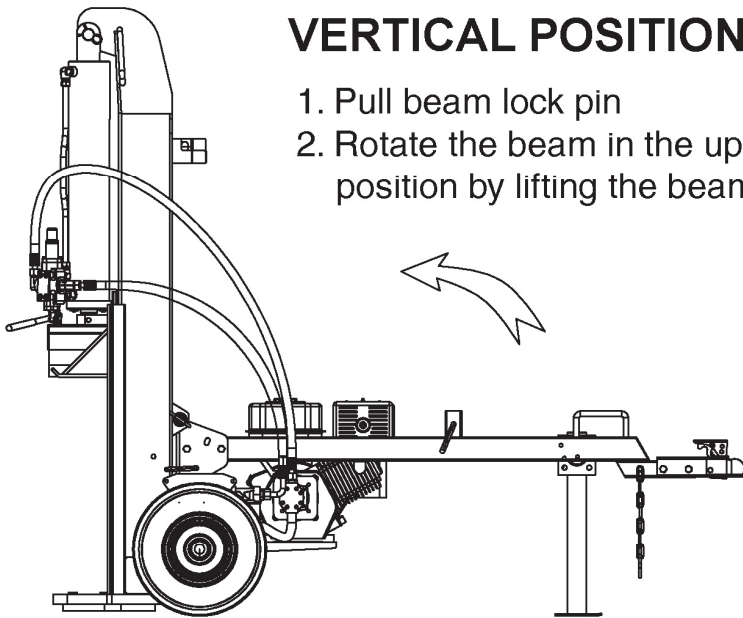

Upright position for splitting large logs.

FOR VEHICLE TOWING

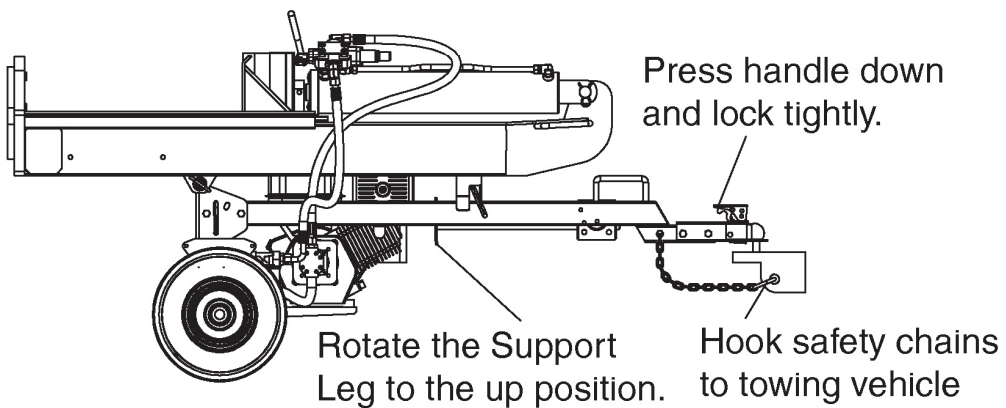

Maintenance and Storage

WARNING

Improper maintenance and storage of the log splitter may void your warranty.

MAINTENANCE

- Before performing maintenance, the log splitter must be placed in maintenance mode. Turn off the engine and move the control lever forward and backwards to relieve the hydraulic pressure.
- After performing any maintenance, make sure all guards, shields and safety features are put back in place before operating the log splitter.
- Before operating make sure the tires have the RECOMMENDED TIRE PRESSURE.
- Regularly grease axle and wheel bearing area or when needed.
- Periodically check all fasteners and hoses for tightness and leaks.
- Annually clean and lightly lubricate all moving parts or when needed.
- Use a glossy enamel spray paint to touch up scratched or worn painted metal surfaces.
- Never exceed load capacity rating of 37 tons it will damage the log splitter.

What	When	How
Hoses	Each Use	Inspect hoses for exposed wire mesh and leaks. Replace all worn or damaged hoses before starting the engine.
Hydraulic Fittings	Each Use	Inspect fittings for cracks and leaks. Replace all damaged fittings before starting the engine.
Nuts and Bolts	Each Use	Check for loose bolts, tighten before operating.
Beam	Each Use	Apply grease to beam surface.
Moving Parts	Each Use	Clear debris from log splitter.

Refer to the Engine Owner's Manual for engine maintenance.

IMPORTANT:

If a part needs replacement, only use parts that meet the manufacturer's specifications. Replacement parts that do not meet specifications may result in a safety hazard or poor operations.

STORAGE

- Before storing make sure the log splitter is clean and dry for years of trouble free service.
- Lightly lubricate all log splitter surfaces and moving parts to prevent rust.
- Store indoors or protected area during severe weather and winter months.

Troubleshooting

Problem	
Cylinder rod will not move	SOLUTION: A,D,E,H,J
Slow cylinder rod speed when extending or retracting	SOLUTION: A,B,C,H,I,K,L
Wood will not split or splits extremely slowly	SOLUTION: A,B,C,F,I,K
Engine bogs down during splitting	SOLUTION: G,L
Engine stalls under low load condition	SOLUTION: D,E,L,M
Engine starts problem	SOLUTION: N
Cause	Solution
A -Insufficient oil to pump	Check oil level in reservoir
B -Air in oil	Check oil level in reservoir
C -Excessive pump inlet vacuum	Check pump inlet hose for blockage or kinks
D -Blocked hydraulic lines	Flush and clean the splitter hydraulic system
E -Blocked control valve	Flush and clean the splitter hydraulic system
F -Low control valve setting	Adjust control valve with a pressure gauge
G -High control valve setting	Adjust control valve with a pressure gauge
H -Damaged control valve	Return control valve for authorized repair
I -Internal control valve leak	Return control valve for authorized repair
J -Internal cylinder leak	Return cylinder for authorized repair
K -Internally damaged cylinder	Return cylinder for authorized repair
L -Engine Control out of adjustment	Adjust idle control nuts
M -Engine is loaded during idle down mode	Use shorter log length (26" or less) to allow engine to speed up before contact.
N -Engine operation	Refer to the English owner's manual

Specifications

Ram Force	37 Ton
Cycle Time	14 Sec
Wedge Size.....	8” Harden Steel
Gear Pump.....	2-Stage
Hydraulic Oil.....	AW32, AW46, ISO32 or Universal Hydraulic Oil
Amount of Hydraulic Fluid	8.8 Gallon
Max. Log Length	26”
Hydraulic Cylinder	5” x 24-1/8”
Max. Pressure.....	3625 PSI
Max. Flow	17 GPM
Wheel Size.....	16” / 4.80-8
Hitch Type.....	2” Ball Coupler
Max. Towing Speed	45 MPH
Manual Start Briggs & Stratton Engine	306CC

NOTE: For Engine Details Refer to the Engine Owner’s Manual.

Parts Drawing & Parts List

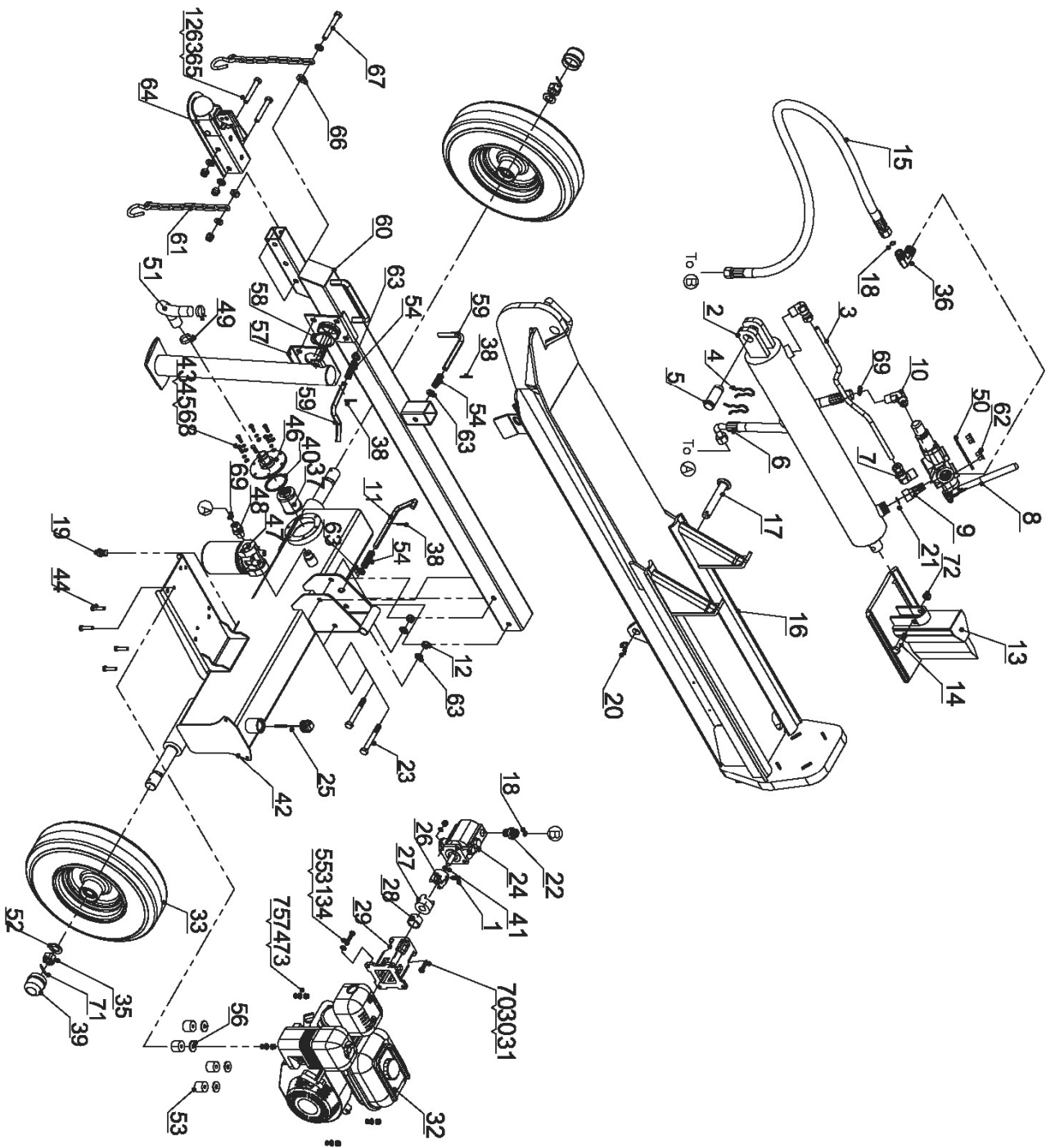

Parts Drawing & Parts List

Ref#	Part No.	Description	Qty
1	9121-06010-FH	Inner Hex Cone Point Set Screw	1
2	LSP37B-03000	Cylinder	1
3	LSP25-00001-DX	Metal Tube	1
4	LSP25-00005-DX	R Pin	2
5	LSP25-00004-DX	Cylinder Pin	1
6	LSP25-00017	Hydraulic Hose (valve-external filter)	1
7	LSP25-06000	Connector	2
8	LSA22-09000	Control Valve	1
9	LSP25-17000	Combination Connector	1
10	LSP25-00002-DX	130° Joint	1
11	LSP25-00006-DX	Safety Pin	1
12	9206-12000-DX	Nylon Lock Nut M12	5
13	LSP30-02000	Wedge Slide	1
14	9101-14080-DX8.8	Hex Bolt M14x80	1
15	LSP30-00002	Hydraulic Hose (valve-pump)	1
16	LSP37B-01000	Beam	1
17	LSP25-05000	Hitch Pin	1
18	9901-14X2.5	O Ring Ø14x2.5	2
19	LSP25-00010-DX	Oil Plug	1
20	LSP25-00012-DX	R Pin	1
21	9901-15X2.5	O Ring Ø15x2.5	1
22	LSA22-00005-DX	Gear Pump Connector	1
23	9101-12100-DX8.8	Hex Bolt M12x100	2
24	LSP37B-02001	Gear Pump	1
25	LSP25-13000	New Oil Bolt	1
26	LSP35-02003	Gear Pump Connector	1
27	LSP30A-10004	Engine Connector	1
28	LSP30A-10002-DX	Engine Axle Sleeve	1
29	LSP30A-10001	Gear Pump Stand	1
30	9206-08000-DX	Nylon Lock Nut M8	4
31	9306-08000-DX	Lock Washer Ø8	8
32	LSP30A-10003	Engine	1
33	LSP25-14000	Wheel	2
34	9301-08000-DX	Flat Washer Ø8	4
35	LSP25-00020-FH	Hex Slotted Thin Nut M20	2
36	LSP30-00003-DX	Angle Connector	1
37	LSP30-00007	Oil Fitter	1
38	9404-03030-DX	Cotter Pin 3x30	3
39	LSP25-00009-DX	Axle Cap	2
40	LSP30-00006	Rubber Washer	1

Ref#	Part No.	Description	Qty
41	LSP25-10008-FH	Steel Wire Snap Ring for Shaft	1
42	LSP30-03000	Oil Tank	1
43	9301-06000-DX	Flat Washer Ø6	6
44	9101-10070-DX8.8	Hex Bolt M10x70	4
45	9101-06020-DX8.8	Hex Bolt M6x20	6
46	LSP30-15000-DX	Filter Fixed Plate	1
47	LSP25-09000	Oil Return Filter	1
48	LSP25-00007-DX	Connector	1
49	LSP25-00011-DX	Clamp	2
50	N29W-00001	Plate	1
51	LSP25-00018	Oil Pipe	1
52	9301-20000-DX	Flat Washer Ø20	2
53	LSP35-00001	Polyurethane Block	4
54	LSP25-00003-DX	Spring	3
55	9101-08025-DX8.8	Hex Bolt M8x25	4
56	9302-10000-DX	Big Flat Washer Ø10	4
57	LSP30-07000	Support Leg	1
58	9304-62000-FH	Steel Wire Snap Ring for Shaft Ø62	1
59	LSP25-00008-DX	Safety Pin	2
60	LSP30-04000	Tow Bar	1
61	LSP25-11000-DX	Chain	2
62	9110-08010-DX	Screw M8x10	4
63	9301-12000-DX	Flat Washer Ø12	9
64	Z103	Coupler	1
65	9101-12080-DX8.8	Hex Bolt M12x80	2
66	LSP25-00015-DX	Thick Washer Ø12	2
67	9101-12090-DX8.8	Hex Bolt M12x90	1
68	9306-06000-DX	Lock Washer Ø6	6
69	9901-17X2.5	O Ring Ø17x2.5	2
70	9101-08030-DX8.8	Hex Bolt M8x30	4
71	9404-04036-DX	Cotter Pin Ø4x36	2
72	9206-14000-DX	Nylon Lock Nut M14	1
73	9206-10000-DX	Nylon Lock Nut M10	4
74	9306-10000-DX	Lock Washer Ø10	4
75	9301-10000-DX	Flat Washer Ø10	4

Limited Warranty

Warranty

For 3 years from the date of purchase YTL International will replace or repair defects in material and workmanship for the original purchaser of the log splitter. For 2 years the engine warranty is covered per the engine manufactures warranty. For 1 year from date of purchase YTL International will repair or replace hydraulic system components. The warranty will not apply to any unit which was not assembled correctly, misused, overloaded or which has been used or operated contrary to our instructions, or which has been repaired or altered by anyone other than a service representative authorized by YTL International Inc.

Warranty Exclusions

This warranty does not cover cosmetic defects such as paint, decals or wear items such as tires. This warranty will not cover failures or problems due to acts of God, or events or forces beyond the control of the manufacturer.

Normal Wear Exclusion

The log splitter needs periodic service to perform well. This warranty does not cover repair when normal use has exhausted the life of a part or the equipment as a whole.

Installation, Use and Maintenance Exclusion

This warranty will not apply to parts and/or labor if the log splitter has been misused, neglected, involved in an accident, abused, loaded beyond its limits, modified or assembled incorrectly. Normal maintenance is not covered under this warranty.

Limits of Implied Warranty and Consequential Damage Exclusion

YTL International disclaims any obligation to cover any loss of time, use of this product, freight, or any incidental or consequential claim by anyone from using this log splitter. THIS WARRANTY IS IN LIEU OF ALL OTHER WARRANTIES, EXPRESS OR IMPLIED, INCLUDING WARRANTIES OF MERCHANTABILITY OR FITNESS FOR A PARTICULAR.

An exchange unit will be subject to the original warranty. The length of the warranty governing the exchanged unit will have the date as the purchase date of the original unit. This warranty gives you certain legal rights which may change from state to state. Your state may also have other rights you may be entitled to that are not listed within this warranty.

Contact Information

YTL International Inc.
17517 Fabrica Way, Suite H
Cerritos, CA 90703
Phone: (888) 723-6534
Phone: (562) 404-8016
Fax: (562) 404-8013
Email: parts@ytlinternational.com
Website: www.ytlinternational.com

Warranty & Customer Support Questions

Phone: (888) 723-6534