



# SERVICE PARTS LIST

**BULLETIN NO.**  
**54-40-6005**

<b>SPECIFY CATALOG NO. AND SERIAL NO. WHEN ORDERING PARTS</b>		REVISED BULLETIN 54-40-6004	DATE Aug. 2015
<b>7-1/4" CIRCULAR SAW with TILT-LOK® HANDLE</b>			
<b>CATALOG NO.</b>	<b>6390-20</b>	<b>SERIAL NUMBER</b>	<b>983F</b>
			<b>WIRING INSTRUCTION</b> <b>See Page 3</b>

**EXAMPLE:**



Component Parts (Small #) Are Included  
When Ordering The Assembly (Large #).

★ = Part number change from  
previous service parts list.

FIG.	PART NO.	DESCRIPTION OF PART	NO. REQ.
1	02-04-0847	Ball Bearing	(1)
2	02-04-1850	Ball Bearing	(1)
3	02-50-2423	Needle Bearing	(1)
★ 4	-----	Switch Screw	(4)
5	45-22-0605	Lower Guard Sleeve	(1)
6	06-75-0035	5/16-18 x 9/16" Blade Screw	(1)
7	06-75-5850	5/16 -18 L.H. Thread Bolt	(1)
8	06-75-5860	1/4-20 x 3/4" Hex Hd. Screw	(1)
9	06-82-5314	10-24 x 1/2" Pan Hd. Taptite T-25	(11)
10	06-82-5358	12-24 x 3/4" Pan Hd. Taptite T-27	(3)
11	06-82-5474	10-24 x 1-3/4" Pan Hd. Taptite T-25	(1)
12	06-82-7270	8-16 x 5/8" Pan Hd. Sl. Plastite T-20	(10)
13	06-82-7395	8-16 x 1-3/4" Pan Hd. Plastite T-20	(2)
14	05-88-0305	K50 x 16mm Delta PT Screw	(3)
15	06-82-0090	10-14 x .562 Plastite T-25 Screw	(2)
16	06-95-6290	M5 x 2.24 x 18 PH (PT) Screw	(1)
18	12-20-6390	Service Nameplate Kit	(1)
19	16-70-0056	Armature Assembly	(1)
20	18-70-0046	Field	(1)
21	22-18-1075	Brush Assembly	(2)
22	22-22-1030	Brush Tube Assembly	(2)
23	22-64-0100	Cord Assembly	(1)
★ 24	23-66-2185	Switch (Includes Switch Screws #4)	(1)
27	25-20-0120	Upper Guard Cover	(1)
28	14-67-0256	Bevel Bracket Assembly	(1)
29	28-14-0100	Gearcase	(1)
30	28-41-1032	Lower Guard Kit	(1)
31	31-05-0045	Baffle	(1)
32	31-15-0465	Motor Cover	(1)
★ 33	31-44-0108	Right Handle Half	(1)
34	31-44-0060	Front Handle	(1)
★ 35	31-44-0107	Left Handle Half	(1)
36	31-44-2156	Handle Lever	(1)
37	31-50-2225	Motor Housing Assembly	(1)
38	31-52-0015	Depth Lever	(1)
39	31-52-0025	Guard Lever	(1)
40	32-75-3205	Gear	(1)
41	34-40-1375	O-Ring	(1)
42	34-40-1380	O-Ring	(1)
43	34-60-0320	External Retaining Ring	(1)
44	34-60-2330	Klip Ring	(1)
45	38-50-0060	Spindle	(1)
46	40-50-0045	Guard Spring	(1)
47	40-50-0055	Compression Spring	(1)
48	40-50-8041	Spring	(1)
49	42-16-0160	Handle Band	(1)
50	42-38-0222	Rubber Bumper	(1)
51	42-42-0275	Spindle Lock Button	(1)
52	43-34-0790	Inner Flange	(1)
53	43-34-0795	Outer Flange	(1)
54	43-78-0155	Hub (With Bearing)	(1)
55	44-10-0130	Bevel Adjustment Lever	(1)
56	44-20-0510	Spindle Lock Pin	(1)
57	44-40-0780	Adjustment Nut	(1)
59	44-60-0075	Thru Pin	(1)
60	44-60-0085	Tapped Pin	(1)
61	44-60-1180	Pivot Pin	(1)
62	44-66-0065	Retaining Plate	(1)
★ 64	44-66-0202	Lock Plate	(1)
65	44-72-0050	Pointer	(1)
66	45-04-0485	Bumper Screw	(1)
68	45-08-0416	Depth Shaft	(1)

FIG.	PART NO.	DESCRIPTION OF PART	NO. REQ.
69	45-16-0160	Shoe Assembly	(1)
70	45-88-0577	Wave Spring Washer	(2)
71	45-88-8461	Washer	(1)
72	45-88-8460	5/16" Washer	(1)
74	49-96-0345	Blade Wrench (Not Shown)	(1)
75	-----	Fan	(1)
80	48-55-9166	Carrying Case	(1)
81	49-22-4146	Rip Fence with two Wing Screws (Not Shown)	(1)

**FIG. NOTE**

- 1 Orient the ball bearing so that the seal faces the commutator.
- 3,29 Orient the needle bearing such that the text is facing the gear. Press the bearing .015" subflush to the gear cavity wall.
- 11 Tighten the handle lever screw such that it requires 3-7 lbs. force to close the handle lever to the locked position.
- 29 Apply .320 - .360 oz. "Y" Grease, No. 49-08-5270, to gear bore of upper guard gearcase. The grease should be directed toward the pinion end of the armature.

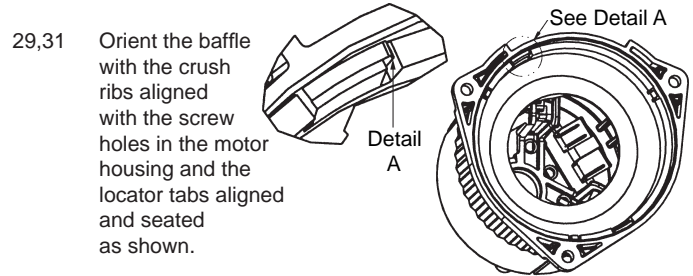

- 29,31 Orient the baffle with the crush ribs aligned with the screw holes in the motor housing and the locator tabs aligned and seated as shown.
- 30 Functionally check the lower guard with the saw set at full depth of cut and zero degree bevel. Place the saw upside down with the shoe horizontal. Retract the lower guard 100%. Release the lower guard lever. The guard should return in a brisk manner.
- 38 When tight, the depth adjustment lever should be parallel (±20°) with the shoe.
- 43 Orient the external retaining ring such that the beveled face is towards the guard.
- 55 When tight, the bevel adjustment lever should be bottomed out on the shoe. (Up to .100" off the shoe is acceptable).
- 28,65 Position the pointer such that the arrow indicates between the zero and one degree mark on the bevel plate scale. Loosen front handle screws to adjust pointer.
- 71 Orient the washer such that the rounded edge is towards the depth rail.
- 72 Orient the washer such that the rounded edge is towards the bevel plate.

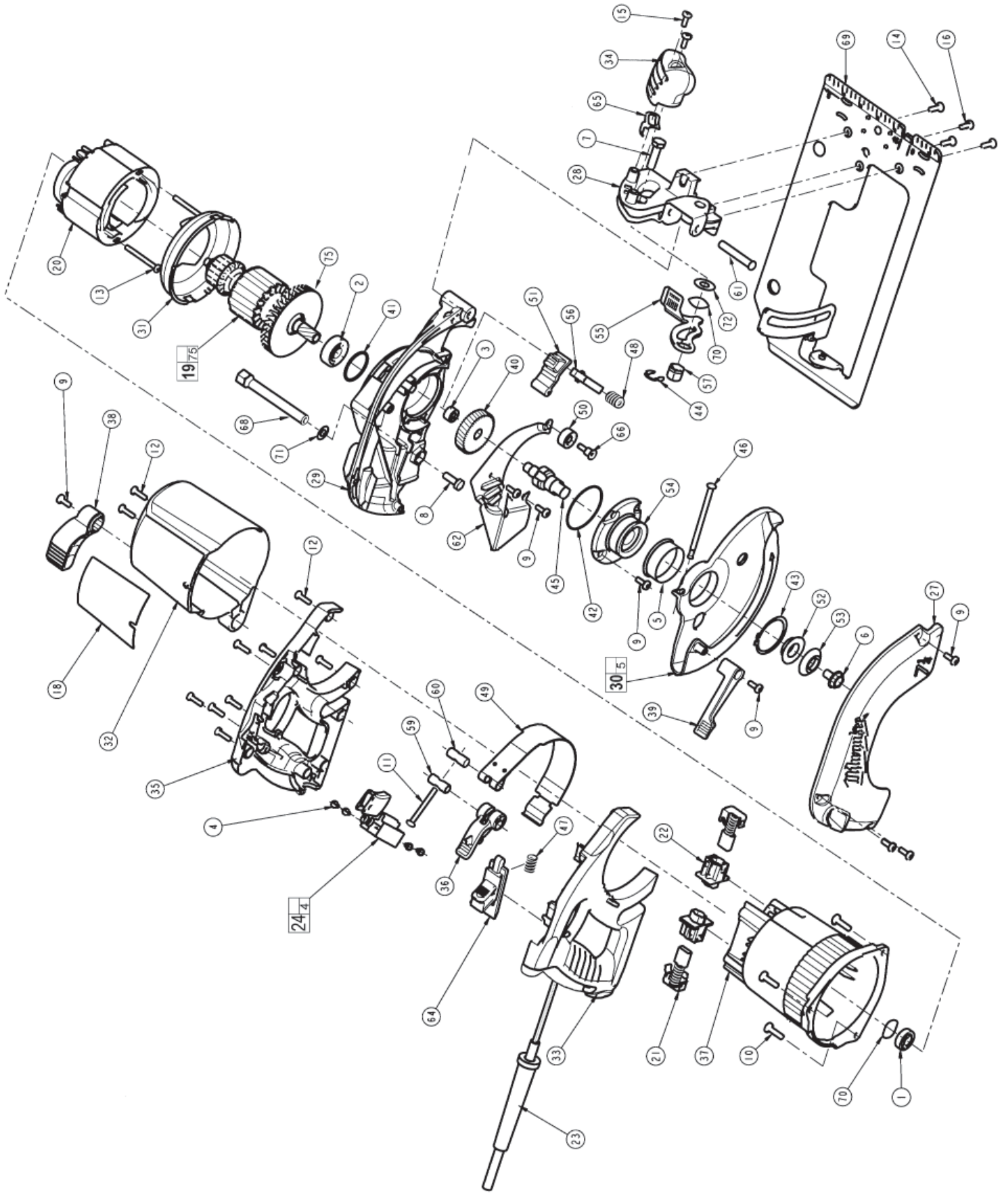

**NOTE:**  
Switch comes with switch screws. Hand tighten to 6.9-10.4 in.-lbs.

Black and white leads from field

Black and white leads from the power cord

**NOTE:**  
White field and cord wires are to be routed to the top terminal positions of the switch. Wires are interchangeable at those top switch positions. Crimp faces of terminals are to face away from switch.

Black field and cord wires are to be routed to the bottom terminal positions of the switch. Wires are interchangeable at those bottom switch positions. Crimp faces of terminals are to face away from switch.

Order of the wires and the placement in traps is interchangeable

Cord jacket to extend .25" minimum beyond cord clamping area

Order of wire placement in trap is interchangeable

Wires can be routed through either trap

